

"SET-FREE" FSG/FS3

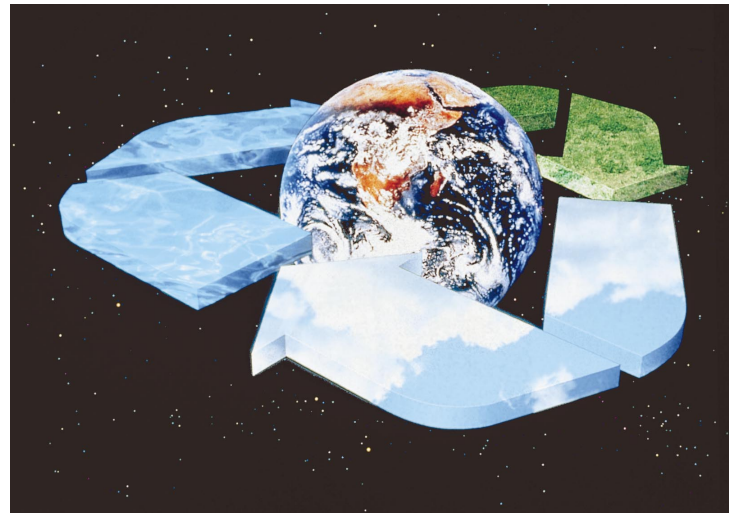

Большая библиотека технической документации
<https://splitsystema48.ru/instrukcii-po-ekspluatacii-kondicionerov.html>
каталоги, инструкции, сервисные мануалы, схемы.

HITACHI
Inspire the Next



Service Manual

Outdoor Units: 5 ~ 20 HP

Indoor Units Type:

- In-the-Ceiling
- 4-Way Cassette
- 2-Way Cassette
- Wall
- Floor
- Floor Concealed
- Ceiling
- Total Heat Exchangers

HITACHI

Specifications in this catalogue are subject to change without notice in order that
HITACHI may bring the latest innovations to their customers

Whilst every effort is made to ensure that all dimensions and specifications are correct,
any printers' errors not rectified are outside the control of HITACHI, who cannot be held
responsible for same

CONTENTS

1. TROUBLESHOOTING

1.1. INITIAL TROUBLESHOOTING.....	1-1
1.1.1. ROTARY SWITCH AND DIP SWITCH SETTING	1-1
1.1.2. CHECKING OF ELECTRICAL WIRING	1-5
1.1.3. CHECKING BY 7-SEGMENT DISPLAY	1-6
1.1.4. EMERGENCY OPERATION WHEN INVERTER COMPRESSOR IS DAMAGED	1-7
1.1.5. FAILURE OF POWER SUPPLY TO INDOOR UNIT AND REMOTE CONTROL SWITCH.....	1-8
1.1.6. ABNORMAL TRANSMISSION BETWEEN REMOTE CONTROL SWITCH AND INDOOR UNIT	1-9
1.1.7. ABNORMALITIES OF DEVICES.....	1-10
1.2. TROUBLESHOOTING PROCEDURE	1-18
1.2.1. ALARM CODE TABLE	1-18
1.2.2. TROUBLESHOOTING BY ALARM CODE	1-19
1.2.3. TROUBLESHOOTING IN CHECK MODE BY REMOTE CONTROL SWITCH.....	1-62
1.2.4. SIMPLE CHECKING BY 7-SEGMENT DISPLAY.....	1-68
1.2.5. FUNCTION OF RSW, DSW AND LEDS	1-76
1.3. PROCEDURE OF CHECKING EACH MAIN PARTS	1-82
1.3.1. SELF CHECKING OF PCBs USING REMOTE CONTROL SWITCH.....	1-82
1.3.2. SELF-CHECKING OF REMOTE CONTROL SWITCH	1-84
1.3.3. SELF-CHECKING OF INDOOR UNIT PCB	1-86
1.3.4. SELF - CHECKING OF 7 - DAY TIMER (PSC-3T).....	1-88
1.3.5. SELF - CHECKING OF CENTRAL STATION (PSC-3S1).....	1-89
1.3.6. PROCEDURE OF CHECKING OTHER MAIN PARTS	1-90
1.4. TEST RUN.....	1-101
1.4.1. TEST RUN MODE REMOTE CONTROL SWITCH.....	1-101
1.4.2. TEST RUN FROM OUTDOOR UNIT SIDE	1-102
1.4.3. CHECKING LIST (FSG AND FS3 SERIES).....	1-103

2. SERVICING

2.1. OUTDOOR UNIT.....	2-1
2.1.1. REMOVING AIR INTAKE GRILLE	2-1
2.1.2. REMOVING FRONT SERVICE PANEL	2-1
2.1.3. REMOVING FAN GUARD NETS	2-1
2.1.4. REMOVING OUTDOOR FAN	2-2
2.1.5. REMOVING COMPRESSOR (RAS-5FSG AND FS3).....	2-3
2.1.6. REMOVING COMPRESSORS (RAS-8FSG, RAS-10FSG, RAS-16FSG, RAS-20FSG, RAS-8FS3, RAS-10FS3, RAS-16FS3 AND RAS-20FS3)	2-5
2.1.7. REMOVING HIGH PRESSURE SWITCH, HIGH PRESSURE SENSOR AND LOW PRESSURE SENSOR	2-7
2.1.8. REMOVING COIL FOR REVERSING VALVE	2-9
2.1.9. REMOVING COIL FOR SOLENOID VALVE.....	2-9
2.1.10. REMOVING THERMISTOR FOR LIQUID PIPE.....	2-9
2.1.11. REMOVING REVERSING VALVE	2-10
2.1.12. REMOVING ELECTRICAL COMPONENTS	2-11
2.2. IN-THE-CEILING TYPE (MODELS: RPI-0.8FSGE, RPI-1.0FSGE, RPI-1.5FSGE, RPI-2.0FSGE, RPI-2.5FSGE, RPI-3.0FSGE, RPI-4.0FSGE AND RPI-5.0FSGE).....	2-12
2.2.1. REMOVING PRINTED CIRCUIT BOARD (PCB)	2-12
2.2.2. REMOVING INDOOR FAN MOTOR	2-13
2.2.3. REMOVING THERMISTORS FOR LIQUID PIPE AND GAS PIPE	2-14
2.2.4. REMOVING FLOAT SWITCH	2-14

2.3. 4-WAY CASSETTE TYPE	2-15
2.3.1. REMOVING LONG LIFE FILTER	2-15
2.3.2. REMOVING INTAKE AIR GRILLE	2-15
2.3.3. REMOVING ELECTRICAL BOX COVER	2-15
2.3.4. REMOVING OPTIONAL AIR PANEL.....	2-15
2.3.5. REMOVING TURBO FAN AND FAN MOTOR.....	2-16
2.3.6. REMOVING PRINTED CIRCUIT BOARD (PCB).....	2-17
2.3.7. REMOVING FLOAT SWITCH.....	2-18
2.3.8. REMOVING DRAIN-UP MECHANISM	2-18
2.3.9. REMOVING DRAIN PAN.....	2-19
2.3.10. REMOVING THERMISTORS FOR LIQUID PIPE AND GAS PIPE.....	2-20
2.3.11. REMOVING EXPANSION VALVE COIL.....	2-20
2.3.12. REMOVING AUTOMATIC LOUVER MOTOR	2-21
2.4. 2-WAY CASSETTE TYPE	2-22
2.4.1. REMOVING LONG LIFE FILTER	2-22
2.4.2. REMOVING INTAKE AIR GRILLE	2-22
2.4.3. REMOVING ELECTRICAL BOX COVER	2-23
2.4.4. REMOVING OPTIONAL AIR PANEL.....	2-23
2.4.5. REMOVING FAN MOTOR	2-24
2.4.6. REMOVING BEARING	2-25
2.4.7. REMOVING COUPLING.....	2-25
2.4.8. REMOVING PRINTED CIRCUIT BOARD (PCB).....	2-25
2.4.9. REMOVING FLOAT SWITCH.....	2-26
2.4.10. REMOVING DRAIN-UP MECHANISM	2-26
2.4.11. REMOVING DRAIN PAN.....	2-26
2.4.12. REMOVING THERMISTORS FOR LIQUID AND GAS PIPES	2-27
2.4.13. REMOVING ELECTRONIC EXPANSION VALVE COIL.....	2-27
2.4.14. REMOVING MOTOR FOR AUTOMATIC LOUVER.....	2-28
2.5. WALL TYPE	2-28
2.5.1. REMOVING AIR FILTER	2-28
2.5.2. REMOVING FRONT PANEL	2-29
2.5.3. REMOVING MOTOR FOR AUTOMATIC LOUVER.....	2-30
2.5.4. REMOVING THERMISTORS FOR LIQUID PIPE, GAS PIPE, DISCHARGE AIR AND SUCTION AIR.....	2-30
2.5.5. REMOVING ELECTRICAL BOX COVER	2-31
2.5.6. REMOVING INDOOR PCB.....	2-32
2.5.7. REMOVING DRAIN PAN.....	2-32
2.5.8. REMOVING HEAT EXCHANGER	2-32
2.5.9. REMOVING FAN AND FAN MOTOR	2-33
2.5.10. REMOVING ELECTRONIC EXPANSION VALVE COIL.....	2-34
2.6. FLOOR TYPE	2-35
2.6.1. REMOVING INTAKE AIR GRILLE	2-35
2.6.2. REMOVING AIR FILTER	2-36
2.6.3. REMOVING DISCHARGE AIR GRILLE.....	2-36
2.6.4. REMOVING FRONT COVER	2-36
2.6.5. REMOVING FAN MOTOR	2-36
2.6.6. REMOVING PRINTED CIRCUIT BOARD (PCB).....	2-37
2.6.7. REMOVING THERMISTORS FOR LIQUID PIPE AND GAS PIPE.....	2-38
2.7. FLOOR CONCEALED TYPE.....	2-39
2.7.1. REMOVING AIR FILTER	2-39
2.7.2. REMOVING FRONT COVERS	2-40
2.7.3. REMOVING FAN MOTOR	2-40
2.7.4. REMOVING PRINTED CIRCUIT BOARD (PCB).....	2-40
2.7.5. REMOVING THERMISTORS FOR LIQUID PIPE AND GAS PIPE.....	2-40
2.8. CEILING TYPE	2-41
2.8.1. REMOVING AIR FILTER	2-41
2.8.2. REMOVING SIDE COVER	2-41
2.8.3. REMOVING DISCHARGE AIR GRILLE.....	2-41
2.8.4. REMOVING FAN MOTOR	2-42
2.8.5. REMOVING BEARING	2-43
2.8.6. REMOVING COUPLING.....	2-44
2.8.7. REMOVING AUTOMATIC LOUVER MOTOR	2-44
2.8.8. REMOVING THERMISTORS FOR LIQUID PIPE AND GAS PIPE.....	2-44
2.8.9. REMOVING PRINTED CIRCUIT BOARD (PCB).....	2-45

2.9. TOTAL HEAT EXCHANGER	2-45
2.9.1. REMOVING AIR FILTER	2-45
2.9.2. REMOVING TOTAL HEAT EXCHANGING ROTOR.....	2-46
2.9.3. REMOVING AIR SUPPLY FAN ASSEMBLY AND EXHAUST FAN ASSEMBLY.....	2-46
2.10. CLEANING INDOOR UNIT HEAT EXCHANGER.....	2-47
2.10.1. REQUIRED TOOLS FOR CLEANING (FOR ALL INDOOR UNITS)	2-47
2.10.2. CLEANING 4-WAY CASSETTE TYPE INDOOR UNIT.....	2-49
2.10.3. CLEANING 2-WAY CASSETTE TYPE INDOOR UNIT.....	2-52
2.10.4. CLEANING WALL TYPE INDOOR UNIT	2-54
2.10.5. CLEANING FLOOR TYPE AND FLOOR CONCEALED TYPE INDOOR UNIT	2-54
2.10.6. CLEANING CEILING TYPE INDOOR UNIT.....	2-56
2.11. REMOVING REMOTE CONTROLLER.....	2-59
2.11.1. REMOVING REMOTE CONTROL SWITCH.....	2-59
2.12. COLLECTING REFRIGERANT FOR REPLACING INDOOR UNIT	2-60

3. MAIN PARTS

3.1. INVERTER	3-1
3.1.1. CALCULATION OF OPERATING FREQUENCY.....	3-1
3.1.2. SPECIFICATIONS OF INVERTER	3-4
3.1.3. ARRANGEMENT OF INVERTER POWER UNIT.....	3-4
3.1.4. PROTECTIVE FUNCTION.....	3-7
3.2. THERMISTOR.....	3-8
3.2.1. RESISTANCE VALUE OF THERMISTOR	3-9
3.3. ELECTRONIC EXPANSION VALVE	3-11
3.3.1. ELECTRONIC EXPANSION VALVE FOR OUTDOOR UNITS	3-11
3.3.2. ELECTRONIC EXPANSION VALVE FOR INDOOR UNITS	3-12
3.4. PRESSURE SENSOR.....	3-13
3.5. NOISE FILTER.....	3-14
3.6. CAPACITOR	3-16
3.7. REACTOR (DCL).....	3-16
3.8. CIRCUIT DIAGRAM FOR PRINTED CIRCUIT BOARD OF OUTDOOR UNIT.....	3-19
3.9. CIRCUIT DIAGRAM FOR PRINTED CIRCUIT BOARD OF INDOOR UNIT	3-23
3.10. CIRCUIT DIAGRAM FOR PRINTED CIRCUIT BOARD OF REMOTE CONTROL SWITCH	3-25
3.11. CIRCUIT DIAGRAM FOR PRINTED CIRCUIT BOARD OF RECEIVER	3-27

4. OPTIONAL FUNCTION

4.1. INDOOR UNIT.....	4-1
4.1.1. REMOTE CONTROL ON/OFF FUNCTION	4-1
4.1.2. POWER SUPPLY ON/OFF 1 (AUTOMATIC OPERATION WHEN POWER SUPPLY ON).....	4-3
4.1.3. POWER SUPPLY ON/OFF 2 (RESTARTING FUNCTION AFTER POWER FAILURE)	4-3
4.1.4. CONTROL BY FIELD-SUPPLIED ROOM THERMOSTAT	4-3
4.1.5. OPERATION CONTROL BY REMOTE TEMPERATURE SENSOR.....	4-4
4.1.6. COOLING OR HEATING OPERATION MODE SETTING CHANGE BY EXTERNAL INPUT (LEVEL SIGNAL INPUT)	4-4
4.1.7. PICKING UP OPERATION SIGNAL	4-5

4.2. OUTDOOR UNIT.....	4-6
4.2.1. DEMAND	4-7
4.2.2. FORCED STOPPAGE	4-7
4.2.3. FIXING OPERATION MODE	4-8
4.2.4. SNOW SENSOR.....	4-8
4.2.5. DEFROSTING CONDITION CHANGEOVER	4-9
4.2.6. INDOOR FAN CONTROL DURING THERMO-OFF AT HEATING.....	4-9
4.2.7. ALL SEASON HEATING OPERATION.....	4-9
4.2.8. ALL SEASON COOLING OPERATION	4-10
4.2.9. NIGHT SHIFT (LOW SOUND) OPERATION	4-10
4.2.10. PICKING UP SIGNALS FROM OUTDOOR UNIT PRINTED CIRCUIT BOARD.....	4-11
4.3. REMOTE CONTROL SWITCH (PC-2H2).....	4-12
4.3.1. NAME OF PARTS.....	4-12
4.3.2. SIMULTANEOUS OPERATION.....	4-13
4.3.3. OPERATION SYSTEM WITH TWO REMOTE CONTROL SWITCHES	4-14
4.3.4. OPTIONAL FUNCTION SETTING	4-14
4.3.5. OPTIONAL FUNCTIONS OF REMOTE CONTROL SWITCH	4-16
4.3.6. INDICATION OF ADDRESS (ADDS) AND REFRIGERANT CYCLE NUMBER (RN).....	4-18
4.4. OPTIONAL WIRELESS REMOTE CONTROL SWITCH, PC-LH3.....	4-19
4.4.1. NAME OF PARTS.....	4-19
4.4.2. IDENTIFYING OF INDOOR UNITS INSTALLED SIDE BY SIDE	4-20
4.4.3. SIMULTANEOUS OPERATION.....	4-20
4.4.4. EMERGENCY OPERATION.....	4-22
4.4.5. OPTIONAL FUNCTION SETTING	4-22
4.4.6. OPTIONAL FUNCTIONS OF WIRELESS REMOTE CONTROL SWITCH.....	4-23
4.5. 7-DAY TIMER (PSC-3T).....	4-24
4.5.1. NAME OF PARTS.....	4-24
4.5.2. OPERATION PROCEDURE FOR RUNNING PATTERN	4-25
4.5.3. OPERATION PROCEDURE FOR OPERATION PATTERN.....	4-25
4.6. OPTIONAL CENTRAL STATION (PSC-3S1).....	4-26
4.6.1. NAME OF PARTS.....	4-26
4.6.2. SYSTEM	4-27
4.6.3. OPERATION PROCEDURE FOR CENTRAL STATION	4-29
5. FIELD WORK INSTRUCTION	5-1
5.1. BURNT-OUT COMPRESSOR DUE TO INSUFFICIENT REFRIGERANT CHARGE.....	5-1
5.2. INSUFFICIENT COOLING PERFORMANCE WHEN A LONG PIPING IS APPLIED	5-1
5.3. ABNORMALLY HIGH OPERATING SOUND (IN-THE-CEILING TYPE INDOOR UNIT).....	5-2
5.4. ALARM CODE "31".....	5-2
5.5. NOT COOLING WELL DUE TO INSUFFICIENT INSTALLATION SPACE FOR OUTDOOR UNIT	5-3
5.6. SELECT GUIDE OF DRAIN PIPE FOR INDOOR UNIT	5-4
5.7. CAUTION ON REFRIGERANT LEAKAGE	5-4
5.8. MAINTENANCE WORK	5-5
5.9. SERVICE & MAINTENANCE RECORD	5-6
5.10. SERVICE & MAINTENANCE RECORD BY 7-SEGMENT DISPLAY	5-7
5.11. SERVICE & MAINTENANCE RECORD BY REMOTE CONTROL SWITCH	5-8

1 TROUBLESHOOTING

1.1 INITIAL TROUBLESHOOTING

1.1.1 ROTARY SWITCH AND DIP SWITCH SETTING

■ INDOOR UNIT

The PCB in the indoor unit is equipped with 7 types of dip switches and rotary switch. Before testing the unit, set these dip switches according to the following instructions. Unless these dip switches are set in the field, the unit can not be operated.

a. Unit No. Setting (RSW)

Setting is required. Set the unit No. of all indoor units respectively and serially, by following setting position shown in the table below. Numbering must start from "0" for every outdoor unit.

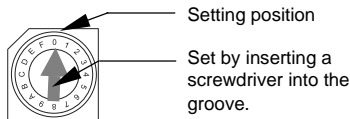

Unit 0	Unit 1	Unit 2	Unit 3
Unit 4	Unit 5	Unit 6	Unit 7
Unit 8	Unit 9	Unit 10	Unit 11
Unit 12	Unit 13	Unit 14	Unit 15

b. Optional Function Setting (DSW2)

Note: The "■" mark indicates position of dip switches. Figures show the setting before shipment.

No setting is required. Setting position before shipment is all OFF.



c. Capacity Code Setting (DSW3)

No setting is required, due to setting before shipment. This switch is used for setting the capacity code which corresponds to the Horse-Power of the indoor unit.

HP	0.8	1.0	1.3	1.5
Setting Position	ON OFF	ON OFF	ON OFF	ON OFF
HP	1.8	2.0	2.3	2.5
Setting Position	ON OFF	ON OFF	ON OFF	ON OFF
HP	2.8	3.0	4.0	5.0
Setting Position	ON OFF	ON OFF	ON OFF	ON OFF

d. Capacity Adjustment Setting (DSW4: Except for RPK model)









No setting is required. Setting position before shipment is all OFF.

HP	0.8~5
Setting Pattern	ON OFF

- e. Refrigerant Cycle No. Setting (DSW5)
Setting is required. Setting position before shipment is all OFF.

HP	0.8~5
Setting Pattern	ON OFF 

- f. Unit Code Setting (DSW6; Except for RPK Model)
No setting is required. Setting positions of the model code for indoor units are shown below.

Model Code	RCI-1.0~5.0 FSGE	RCD-1.0, 1.5 FSG	RCD-2.0~5.0 FSG(E)
Setting Position	ON OFF 	ON OFF 	ON OFF 
Model Code	RPI-0.8~1.5 FSGE	RPI-2.0~5.0 FSGE	RPC-2.0~5.0 FSGE
Setting Position	ON OFF 	ON OFF 	ON OFF 
Model Code	RPF, RPFI-1.0 FSG(E)	RPF, RPFI-1.5 FSG(E)	-
Setting Position	ON OFF 	ON OFF 	-

- g. Fuse Recover (DSW7) (for Auxiliary use)
No setting is required. Setting position before shipment is all OFF.

HP	0.8~5
Setting Pattern	ON OFF 

Note: The “■” mark indicates position of dip switches.
Figures show the setting before shipment.

CAUTION:

Before setting dip switches, firstly turn OFF power source and set the position of the dip switches. If the switches are set without turning OFF the power source, the switches can not function.

OUTDOOR UNIT

TURN OFF all power sources before setting. Without turning OFF, the switches do not work and the contents of the setting are invalid. Mark of “■” indicates the position of dip switches. Set the dip switches according to the next information.

Quantity and Position of Dip Switches:

The PCB in the outdoor unit is operated with 10 types of dip switches and 3 types of push switch.

Dips switches position is the following:

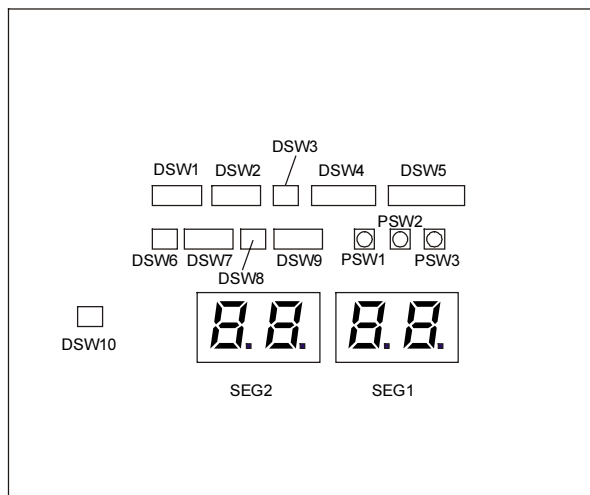

Note: The mark “■” indicates position of dips switches.
Figures show setting before shipment or after selection.

By using DSW4, 7 or 8 the unit is started or stopped after 10 to 20 seconds after the switch is operated. Make the outdoor unit No. clear to distinguish from other outdoor units for service and maintenance.

CAUTION:

Check to ensure that the #8 pin of DSW5 is correctly set according to the power supply of the unit. If the setting is different from the power supply of the unit, it may cause the unit stoppage due to alarm or the breakdown of the compressor. Before setting dips switches, firstly turn off power source and set the position of the dips switches. If the switches are set without turning off the power source, the contents of the setting are invalid. Setting for transmission is required to set the refrigerant cycle Nos. and end terminal for this H-link system.

■ DSW1: Refrigerant cycle no. setting

Setting is required if H-Link is used. Setting position before shipment are all OFF (Refrigerant cycle No. 0). In the same Refrigerant Cycle set the same refrigerant cycle no. for the outdoor unit and for the indoor units as shown below.

Cycle No.	0	1	2	3
Setting Position	ON OFF <input type="checkbox"/> <input type="checkbox"/> <input type="checkbox"/> <input type="checkbox"/> 1 2 3 4	ON OFF <input type="checkbox"/> <input type="checkbox"/> <input type="checkbox"/> <input type="checkbox"/> 1 2 3 4	ON OFF <input type="checkbox"/> <input type="checkbox"/> <input type="checkbox"/> <input type="checkbox"/> 1 2 3 4	ON OFF <input type="checkbox"/> <input type="checkbox"/> <input type="checkbox"/> <input type="checkbox"/> 1 2 3 4
Cycle No.	4	5	6	7
Setting Position	ON OFF <input type="checkbox"/> <input type="checkbox"/> <input type="checkbox"/> <input type="checkbox"/> 1 2 3 4	ON OFF <input type="checkbox"/> <input type="checkbox"/> <input type="checkbox"/> <input type="checkbox"/> 1 2 3 4	ON OFF <input type="checkbox"/> <input type="checkbox"/> <input type="checkbox"/> <input type="checkbox"/> 1 2 3 4	ON OFF <input type="checkbox"/> <input type="checkbox"/> <input type="checkbox"/> <input type="checkbox"/> 1 2 3 4
Cycle No.	8	9	10	11
Setting Position	ON OFF <input type="checkbox"/> <input type="checkbox"/> <input type="checkbox"/> <input type="checkbox"/> 1 2 3 4	ON OFF <input type="checkbox"/> <input type="checkbox"/> <input type="checkbox"/> <input type="checkbox"/> 1 2 3 4	ON OFF <input type="checkbox"/> <input type="checkbox"/> <input type="checkbox"/> <input type="checkbox"/> 1 2 3 4	ON OFF <input type="checkbox"/> <input type="checkbox"/> <input type="checkbox"/> <input type="checkbox"/> 1 2 3 4
Cycle No.	12	13	14	15
Setting Position	ON OFF <input type="checkbox"/> <input type="checkbox"/> <input type="checkbox"/> <input type="checkbox"/> 1 2 3 4	ON OFF <input type="checkbox"/> <input type="checkbox"/> <input type="checkbox"/> <input type="checkbox"/> 1 2 3 4	ON OFF <input type="checkbox"/> <input type="checkbox"/> <input type="checkbox"/> <input type="checkbox"/> 1 2 3 4	ON OFF <input type="checkbox"/> <input type="checkbox"/> <input type="checkbox"/> <input type="checkbox"/> 1 2 3 4

■ DSW2: Capacity settings

Not setting is required. Each outdoor unit is set as shown before shipment.

R22	Setting Position	R407C	Setting Position
RAS-5FS3	ON OFF <input type="checkbox"/> <input type="checkbox"/> <input type="checkbox"/> <input type="checkbox"/> 1 2 3 4	RAS-5FSG	ON OFF <input type="checkbox"/> <input type="checkbox"/> <input type="checkbox"/> <input type="checkbox"/> 1 2 3 4
RAS-8FS3	ON OFF <input type="checkbox"/> <input type="checkbox"/> <input type="checkbox"/> <input type="checkbox"/> 1 2 3 4	RAS-8FSG	ON OFF <input type="checkbox"/> <input type="checkbox"/> <input type="checkbox"/> <input type="checkbox"/> 1 2 3 4
RAS-10FS3	ON OFF <input type="checkbox"/> <input type="checkbox"/> <input type="checkbox"/> <input type="checkbox"/> 1 2 3 4	RAS-10FSG	ON OFF <input type="checkbox"/> <input type="checkbox"/> <input type="checkbox"/> <input type="checkbox"/> 1 2 3 4
RAS-16FS3	ON OFF <input type="checkbox"/> <input type="checkbox"/> <input type="checkbox"/> <input type="checkbox"/> 1 2 3 4	RAS-16FSG	ON OFF <input type="checkbox"/> <input type="checkbox"/> <input type="checkbox"/> <input type="checkbox"/> 1 2 3 4
RAS-20FS3	ON OFF <input type="checkbox"/> <input type="checkbox"/> <input type="checkbox"/> <input type="checkbox"/> 1 2 3 4	RAS-20FSG	ON OFF <input type="checkbox"/> <input type="checkbox"/> <input type="checkbox"/> <input type="checkbox"/> 1 2 3 4

■ DSW3: High difference

Setting is required

<ul style="list-style-type: none"> Setting Before shipment The Outdoor Unit is located higher than Indoor Unit (0~50m) The Outdoor Unit is located lower than Indoor Unit (0~20m) 	ON OFF <input type="checkbox"/> <input type="checkbox"/> 1 2
<ul style="list-style-type: none"> The Outdoor Unit is located lower than Indoor Unit (20~40m) 	ON OFF <input type="checkbox"/> <input type="checkbox"/> 1 2

■ DSW4: Test Operation & Service Settings

Setting is required. This dip switch is utilized for test operation or when servicing operation is performed.

<ul style="list-style-type: none"> Setting before shipment 	ON OFF <input type="checkbox"/> <input type="checkbox"/> <input type="checkbox"/> <input type="checkbox"/> <input type="checkbox"/> <input type="checkbox"/> 1 2 3 4 5 6
<ul style="list-style-type: none"> Test Cooling Operation 	ON OFF <input type="checkbox"/> <input type="checkbox"/> <input type="checkbox"/> <input type="checkbox"/> <input type="checkbox"/> <input type="checkbox"/> 1 2 3 4 5 6
<ul style="list-style-type: none"> Test Heating Operation 	ON OFF <input type="checkbox"/> <input type="checkbox"/> <input type="checkbox"/> <input type="checkbox"/> <input type="checkbox"/> <input type="checkbox"/> 1 2 3 4 5 6
<ul style="list-style-type: none"> Enforced Compressor Stop 	ON OFF <input type="checkbox"/> <input type="checkbox"/> <input type="checkbox"/> <input type="checkbox"/> <input type="checkbox"/> <input type="checkbox"/> 1 2 3 4 5 6

■ DSW5: Optional Function Setting

Setting is required. Set the dip switch according to your requirements.





<ul style="list-style-type: none"> Before shipment Power Supply 380/50-60 Hz 	ON OFF <input type="checkbox"/> <input type="checkbox"/> <input type="checkbox"/> <input type="checkbox"/> <input type="checkbox"/> <input type="checkbox"/> <input type="checkbox"/> <input type="checkbox"/> 1 2 3 4 5 6 7 8
<ul style="list-style-type: none"> Circulator Function of Heating Thermo OFF 	ON OFF <input type="checkbox"/> <input type="checkbox"/> <input type="checkbox"/> <input type="checkbox"/> <input type="checkbox"/> <input type="checkbox"/> <input type="checkbox"/> <input type="checkbox"/> 1 2 3 4 5 6 7 8
<ul style="list-style-type: none"> Night Shift (Low noise) 	ON OFF <input type="checkbox"/> <input type="checkbox"/> <input type="checkbox"/> <input type="checkbox"/> <input type="checkbox"/> <input type="checkbox"/> <input type="checkbox"/> <input type="checkbox"/> 1 2 3 4 5 6 7 8
<ul style="list-style-type: none"> Cancellation of Outdoor amb. temp. limit of Heating 	ON OFF <input type="checkbox"/> <input type="checkbox"/> <input type="checkbox"/> <input type="checkbox"/> <input type="checkbox"/> <input type="checkbox"/> <input type="checkbox"/> <input type="checkbox"/> 1 2 3 4 5 6 7 8
<ul style="list-style-type: none"> Cancellation of Outdoor amb. temp. limit of Cooling 	ON OFF <input type="checkbox"/> <input type="checkbox"/> <input type="checkbox"/> <input type="checkbox"/> <input type="checkbox"/> <input type="checkbox"/> <input type="checkbox"/> <input type="checkbox"/> 1 2 3 4 5 6 7 8
<ul style="list-style-type: none"> Defrosting condition change for Cold Area 	ON OFF <input type="checkbox"/> <input type="checkbox"/> <input type="checkbox"/> <input type="checkbox"/> <input type="checkbox"/> <input type="checkbox"/> <input type="checkbox"/> <input type="checkbox"/> 1 2 3 4 5 6 7 8
<ul style="list-style-type: none"> Power Supply 415/50 Hz 	ON OFF <input type="checkbox"/> <input type="checkbox"/> <input type="checkbox"/> <input type="checkbox"/> <input type="checkbox"/> <input type="checkbox"/> <input type="checkbox"/> <input type="checkbox"/> 1 2 3 4 5 6 7 8
<ul style="list-style-type: none"> Power supply 220/60Hz 	ON OFF <input type="checkbox"/> <input type="checkbox"/> <input type="checkbox"/> <input type="checkbox"/> <input type="checkbox"/> <input type="checkbox"/> <input type="checkbox"/> <input type="checkbox"/> 1 2 3 4 5 6 7 8

■ DSW6: Piping Length

<ul style="list-style-type: none"> Before shipment and length < 25 m 	ON OFF <input type="checkbox"/> <input type="checkbox"/> 1 2
<ul style="list-style-type: none"> 25 ≤ Total length < 50 	ON OFF <input type="checkbox"/> <input type="checkbox"/> 1 2
<ul style="list-style-type: none"> 50 ≤ Total length < 75 	ON OFF <input type="checkbox"/> <input type="checkbox"/> 1 2
<ul style="list-style-type: none"> 75 ≤ Total length < 100 	ON OFF <input type="checkbox"/> <input type="checkbox"/> 1 2



■ DSW7: Compressor Emergency Operation

Setting is not required. All compressor are running except compressor selected

▪ <i>Before shipment</i>	ON OFF 
▪ <i>Except Compressor No. 1</i>	ON OFF 
▪ <i>Except Compressor No. 2</i>	ON OFF 
▪ <i>Except Compressor No. 3</i>	ON OFF 
▪ <i>Except Compressor No. 4</i>	ON OFF 

■ DSW8: Test Operation & Service Setting II

No setting is required.

▪ <i>Before shipment</i>	ON OFF 
▪ <i>Exchanged Compressor Operation</i>	ON OFF 





■ DSW9: Optional Functions Setting II

No setting is required.

▪ <i>Before shipment</i>	ON OFF 
--------------------------	--------------------------------------------------------------------------------------------

■ DSW10: Transmitting Setting

Setting is required for cancellation of end resistance and when fuse is melted.

▪ <i>Before shipment, No. 1 pin of DSW10 is set at ON side</i>	ON OFF 
▪ <i>In case that Outdoor Unit quantity in the same H-Link is 2 or more, set No. 1 pin of DSW10 at the OFF side from 2nd Unit. If only one Outdoor Unit is used, no setting is required.</i>	ON OFF 
▪ <i>In case of applying high voltage to the terminal 1, 2 of TB1, the fuse on the PCB is cut.</i>	ON OFF 
▪ <i>In such a case, first connect the wiring to TB1 and then turn on #2</i>	ON OFF 

■ Push switch

Manual defrosting	PSW1
for Check	PSW2 PSW3

1.1.2 CHECKING OF ELECTRICAL WIRING

- Check to ensure that the terminal for power source wiring (terminals "L1" to "L1" and "N" to "N" of each terminal board: AC380-415V, terminals "R" to "R" and "T" to "T" of each terminal board: AC220V) and intermediate wiring (Operating Line: terminals "1" to "1" and "2" to "2" of each terminal board: DC5V) between the indoor unit and the outdoor unit coincide correctly, as figure below. If not, some component will be damaged.
- Check to ensure that the twist pair cable with shield ($\geq 0.75 \text{ mm}^2$) are used for intermediate wiring to protect noise obstacle at total length of less than 1000 m and size complied with local code.
- Check to ensure that the wirings and the breakers are chosen correctly, as shown in table beside.
- All the field wiring and equipment must comply with local code.

Electrical Data and Recommended Wiring, Breaker Size/1 Outdoor Unit

Model	Power Supply	Max Running Current (A)	Power Supply Line (Ø mm)	ELB		Fuse (A)
				Nominal current (A)	Nominal Sensitive Current (mA)	
RAS-5FSG RAS-5FS3	380-415V 50Hz	18	MLFC 0.75SQ	20	30	20
RAS-8FSG RAS-8FS3		28	MLFC 2SQ	30		30
RAS-10FSG RAS-10FS3		35	MLFC 3.5SQ	40		40
RAS-16FSG RAS-16FS3		57	MLFC 5.5SQ	>57 (Ex. 60)		60
RAS-20FSG RAS-20FS3		71	MLFC 8SQ	>71 (Ex. 75)		75

ELB: Earth leakage Breaker: Apply low sensibility type.
MLFC: Flame Retardant Polyflex Wire.

Note: Regarding the wiring or breakers, follow to the local code.

Example for Electrical Wiring Connection of FSG and FS3 System

Max. 4 Outdoor Units / Power supply line (5, 8, 10 HP)
1 Outdoor Unit / Power supply line (16, 20 HP)

Outdoor Unit

Models: RAS-5FSG
RAS-5FS3
RAS-8FSG
RAS-8FS3
RAS-10FSG
RAS-10FS3
RAS-16FSG
RAS-16FS3
RAS-20FSG
RAS-20FS3

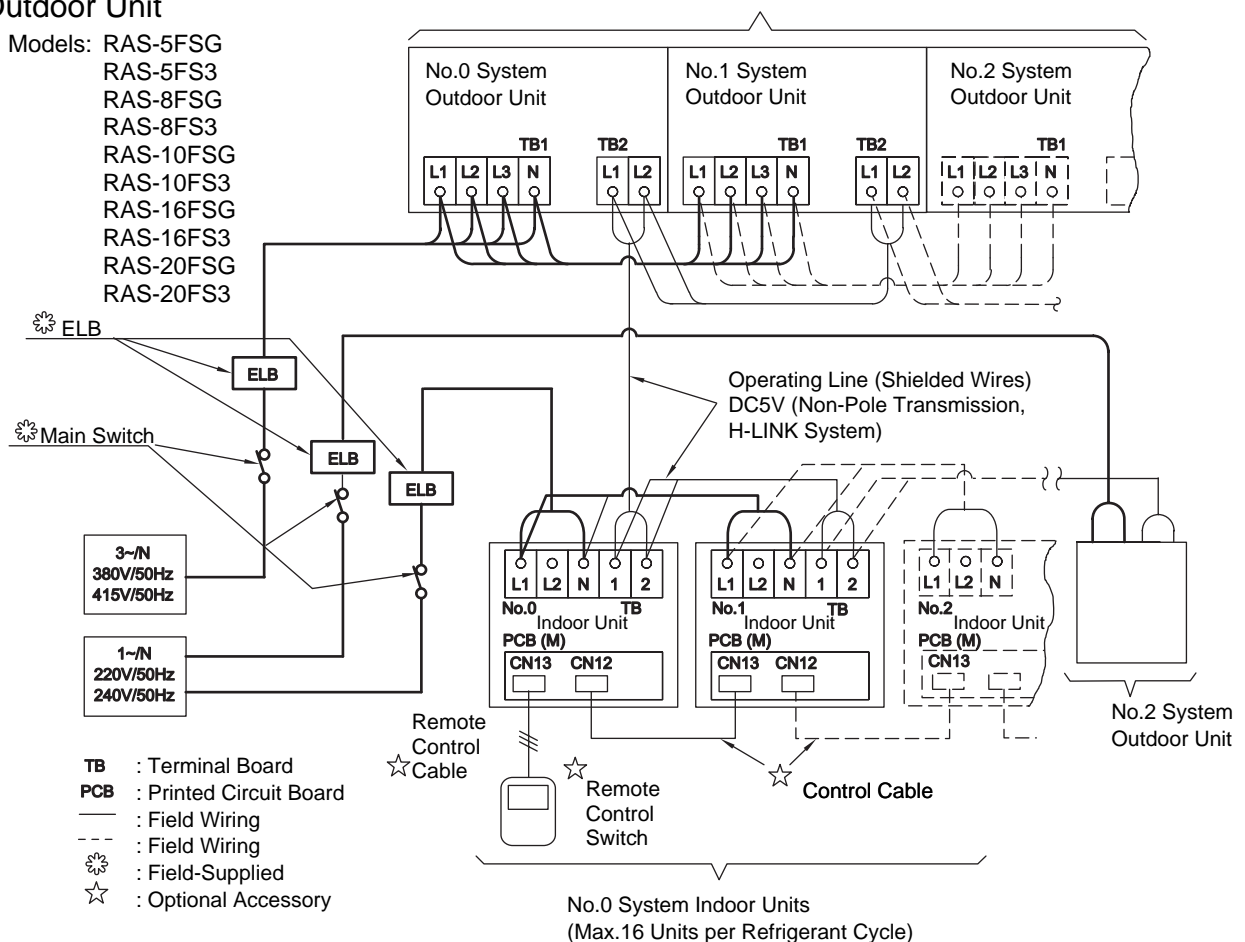

1.1.3 CHECKING BY 7-SEGMENT DISPLAY

■ Simple checking by 7-Segment Display

1 ❖ Turn on All Indoor Units

❖ All the Indoor Units Connected to the Outdoor Unit

2 Turn on the Outdoor Unit

3 Turn Auto-addressing starts

Outdoor Unit
Printed
Circuit Board
PCB 1

During auto-addressing, the following items can be checked using the outdoor unit's on-board 7-segment LED display.



1. Disconnection of power supply to the Indoor Unit.
2. Duplication of Indoor Unit number.

Normal Case

The outdoor unit's on board 7-segment LED display is not indicated.

Abnormal
Case

The outdoor unit's on board 7-segment LED display indicates as follows if there is something wrong

- a. The indoor units are not supplied with power. →  continues to flash after 30 seconds.
- b. Disconnection of the operating line between the outdoor and indoor units. →  continues to flash after 30 seconds.
- c. Duplicated settings of the indoor unit number rotary switch RSW (Refer to the description of alarm code 35", in the item 1.2.2, Troubleshooting by Alarm Code".)

1.1.4 EMERGENCY OPERATION WHEN INVERTER COMPRESSOR IS DAMAGED

■ Failure of Inverter Compressor

- a. Contents of Operation (Applied Models: RAS-8FS3(G), 10FS3(G), 16FS3(G), 20FS3(G))
1. This operation is an emergency operation by a constant compressor, when the inverter compressor is failed.
 2. By turning ON "#1" of DSW7 on PCB1 and "#1" of DSW1 on PCB3, emergency operation is started.
 3. Control of the emergency operation is same with normal control except the inverter compressor stoppage.

b. Operating Condition

The constant speed compressor is forced to be stopped for compressor protection under the condition below:

Total Capacity of Thermo-ON indoor units
< 50% of Outdoor Unit Capacity

In case of the above condition, the compressor is operated and stopped repeatedly, and it may cause the compressor failure. Therefore, the compressor is forced to be stopped to protect it.

Note: *If the printed circuit board for inverter (PCB3) is damaged, this is not available.*

c. Method of Emergency Operation

Checking Before Emergency Operation.

1. Measure insulation resistance of the inverter compressor.
Do not perform the emergency operation when the insulation resistance is 0 Ω.
There is a possibility that refrigerant oil may be oxidized, if the emergency operation is performed, the other compressor is damaged.
2. In case of total capacity of Thermo-ON indoor units are more than 50% of outdoor unit capacity, emergency operation is available.
3. In this emergency operation, frequency of the compressor is not controlled at each 1Hz.
Therefore, alarm code "07", "43", "44", "45" or "47" may be indicated on LCD. Details of alarm codes are shown in the alarm code table (page 1-18).
4. This emergency operation does not provide sufficient cooling and heating capacity.
5. This method is an emergency operation temporarily when the inverter compressor is damaged. Therefore, change the new one as soon as possible.
6. Turn OFF "#1" of DSW7 on PCB1 and "#1" of DSW1 on PCB3 after changing the new compressor. If this setting is not performed, the inverter compressor will be damaged.

d. Emergency Operation

1. Turn OFF all the power source switches.
2. Disconnect the wiring from the inverter compressor. Insulate the faston terminals for invertercompressor wires by insulation tape.
3. Set the No.1 of DSW7 on the PCB1 and No.1 of DSW1 on the PCB3 at the "ON" side.
4. Turn ON all the power source switches.
5. Operate the system by remote control switches.
6. The system is stopped by turning OFF all the remote control switches or turning OFF all the power source switches.

■ Failure of Constant Speed Compressor

- a. Contents of Operation (Applied Models: RAS-8FS3(G), 10FS3(G), 16FS3(G), 20FS3(G))

1. This operation is an emergency operation by the inverter compressor, when the constant speed compressor is failed.
2. This operation is controlled by a normal control.

b. Operating Condition

1. Set the No.2 of DSW7 on the PCB1 at the "ON" side.
2. Temperature of THM2, THM3 and THM4 on the top of compressors are not ignored by setting DSW7.

If the thermistor is short-circuited or cut, this operation is available.

1.1.5 FAILURE OF POWER SUPPLY TO INDOOR UNIT AND REMOTE CONTROL SWITCH

■ Lights and LCD are not Indicated.

■ Not Operated

If fuses are melted or a breaker is activated, investigate the cause of over current and take necessary action.

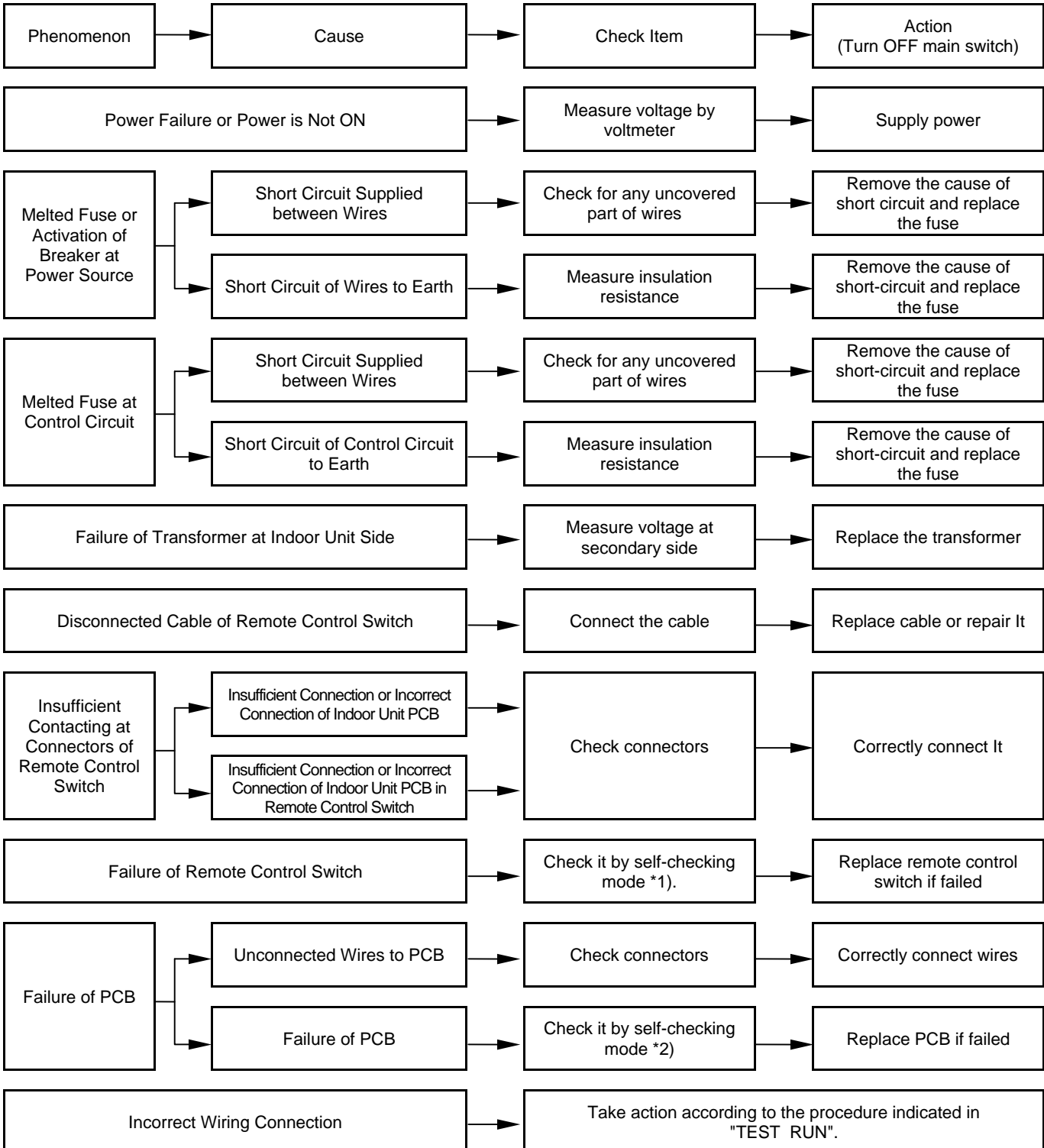

*1): Refer to Item 1.3.2.

*2): Refer to Item 1.3.1.

1.1.6 ABNORMAL TRANSMISSION BETWEEN REMOTE CONTROL SWITCH AND INDOOR UNIT

- "RUN" Lamp on Remote Control Switch:
Flickering every 2 seconds

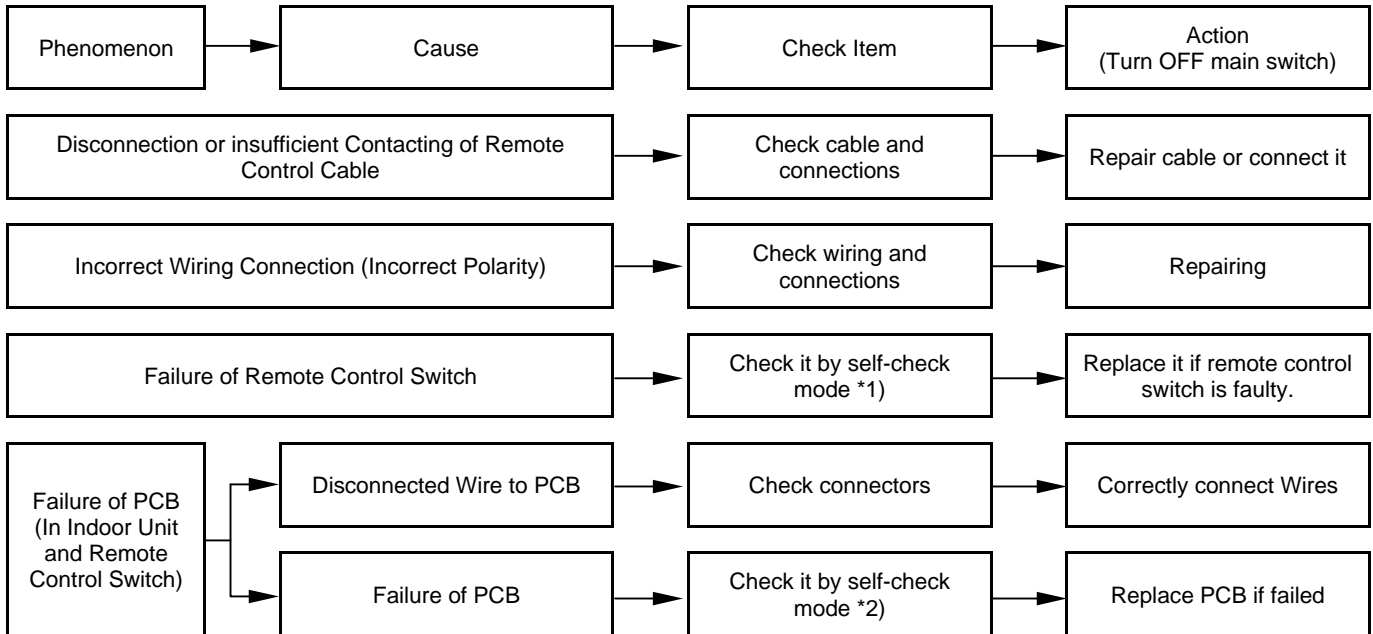

*1): Refer to Item 1.3.2.

*2): Refer to Item 1.3.1.

*3): This phenomenon occurs when the system is newly installed and is started within 5 minutes after power supply, since automatic setting of unit No. is performed during this period.

1.1.7 ABNORMALITIES OF DEVICES

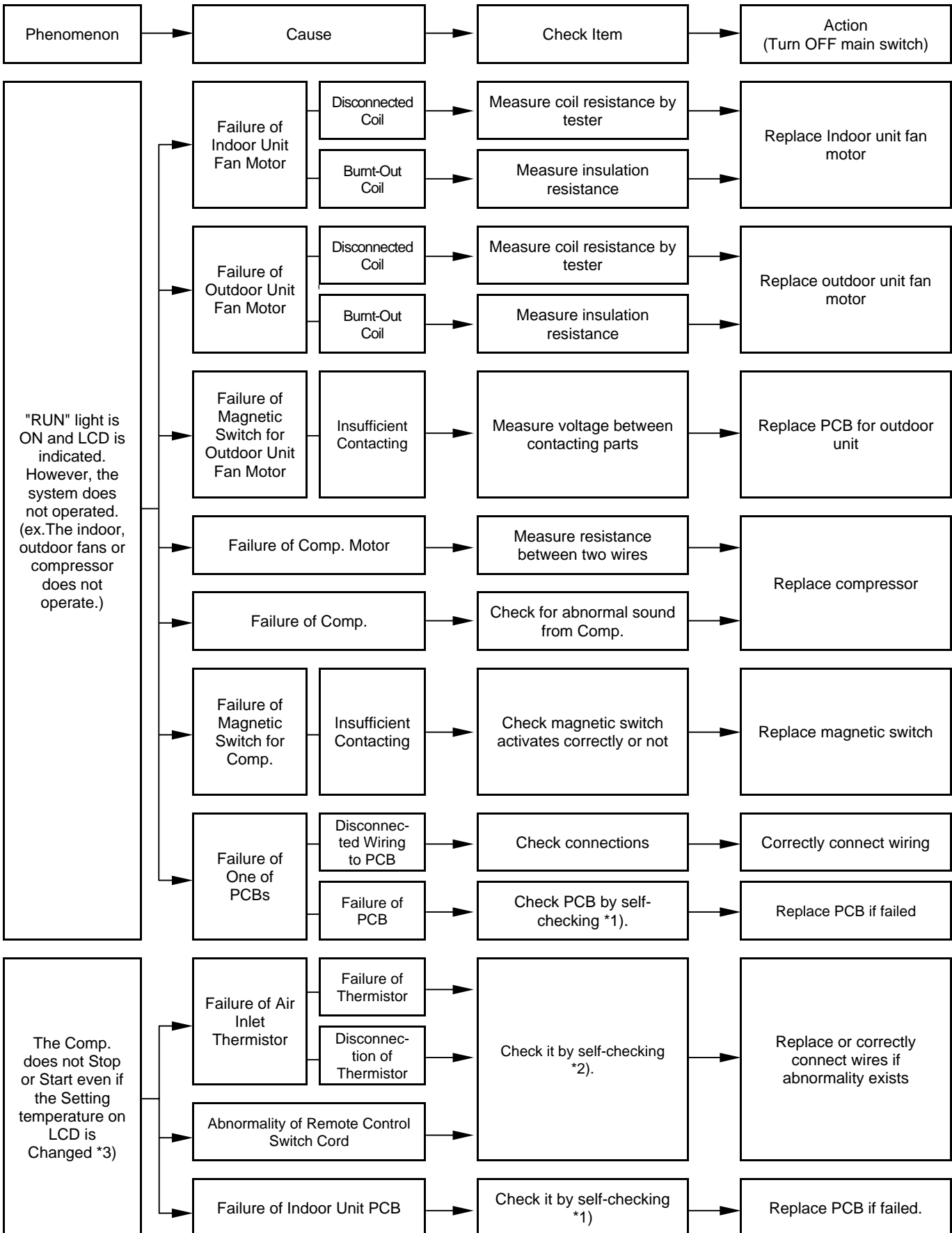

1.1.7 ABNORMALITIES OF DEVICES (Cont.)

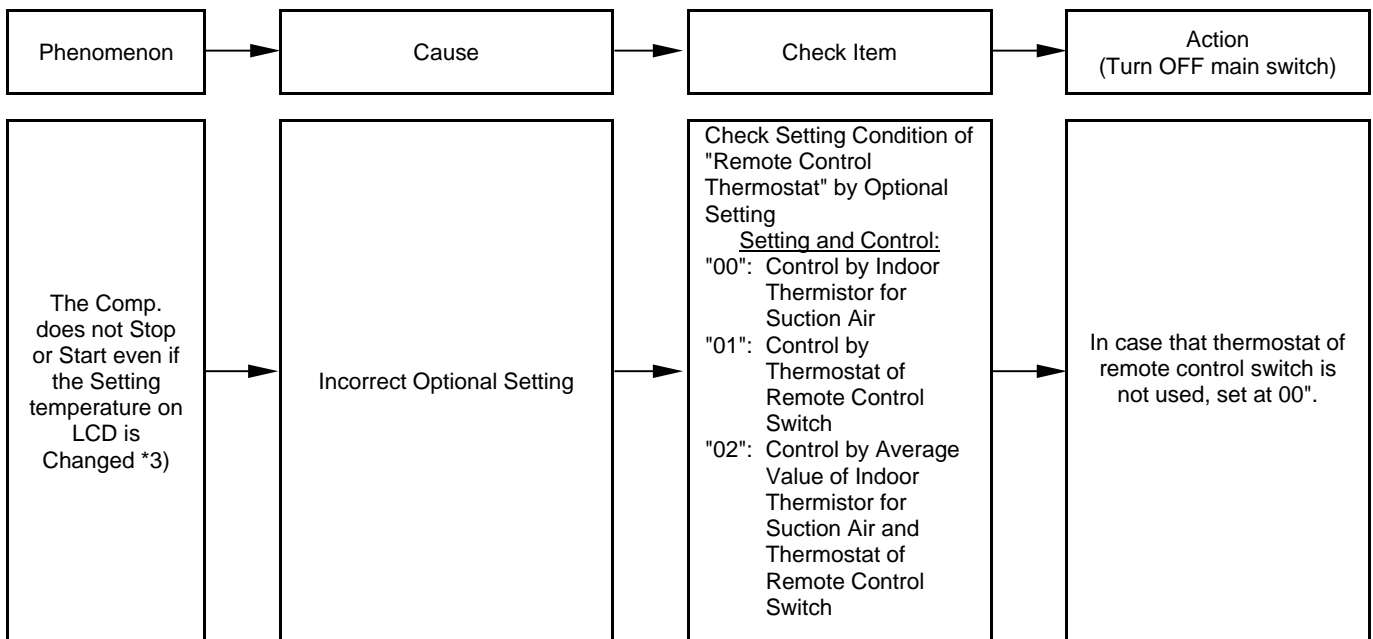

*1): Refer to Item 1.3.1~1.3.4.

*2): Refer to Item 1.3.1.

*3): Even if controllers are normal, the compressor does not operate under the followings conditions:

1. Indoor Air Temp. is lower than 21°C or Outdoor Air Temp. is lower than -5°C during cooling operation.
2. Indoor Air Temp. is higher than 30°C or Outdoor Air Temp. is higher than 23°C during heating operation.
3. When a cooling (or heating) operation signal is given to the outdoor unit and a different mode as heating (or cooling) operation signal is given to indoor units.
4. When an emergency stop signal is given to outdoor unit.

1.1.7 ABNORMALITIES OF DEVICES (Cont.)

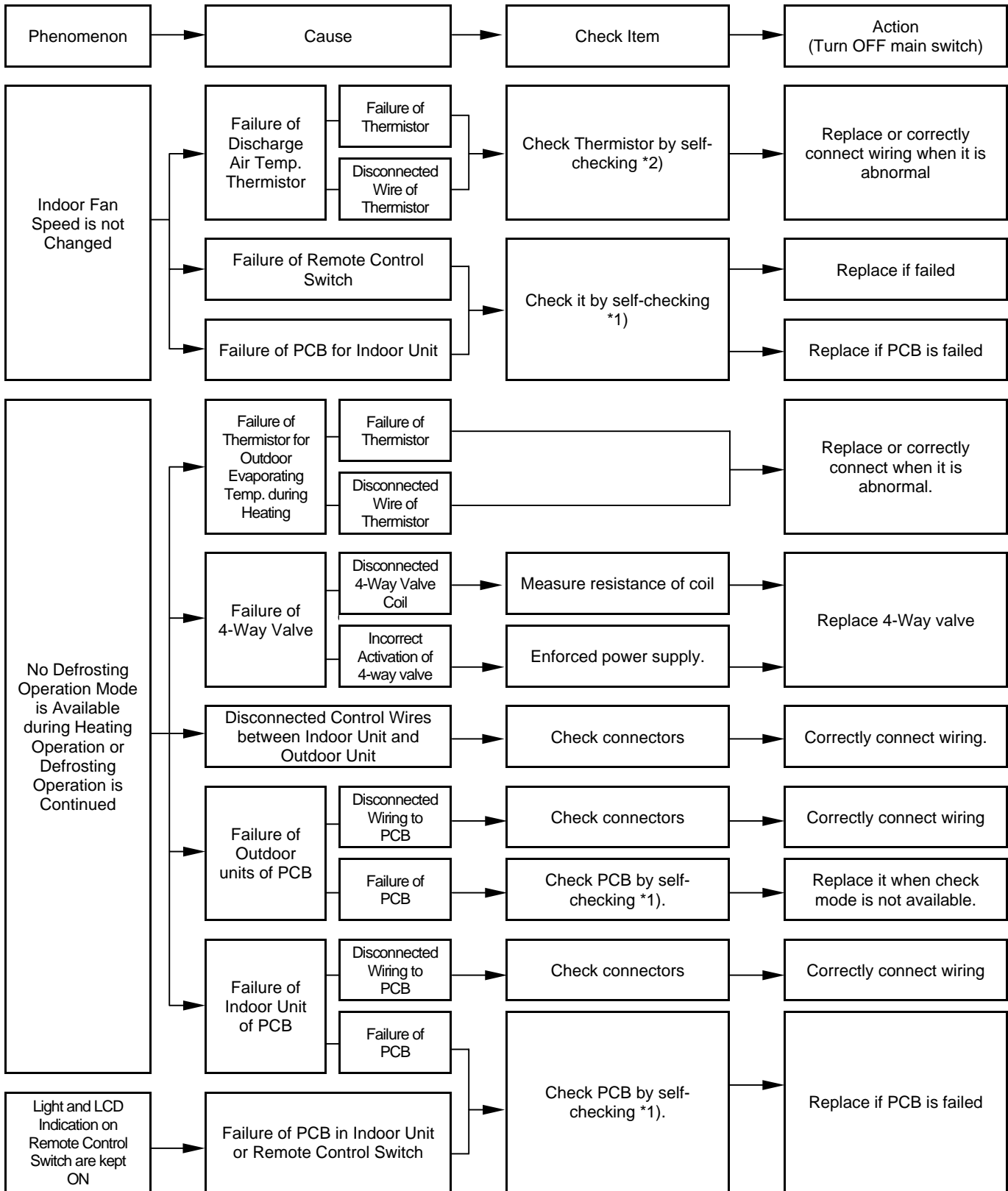

*1): Refer to Item 1.3.1~1.3.4.

*2): Refer to Item 1.3.1.

1.1.7 ABNORMALITIES OF DEVICES (Cont.)

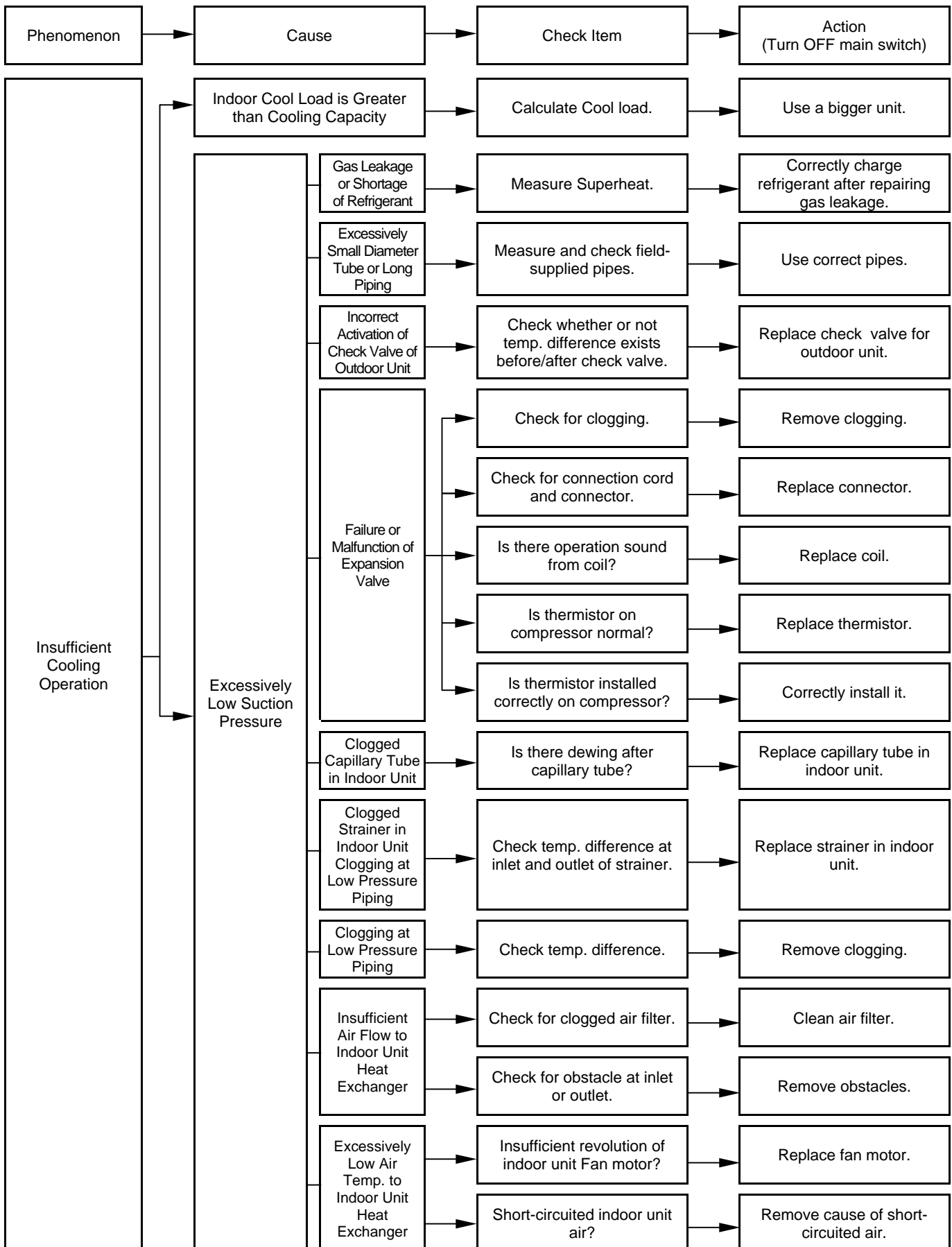

*1): Refer to Item 16.6 of TC

1.1.7 ABNORMALITIES OF DEVICES (Cont.)

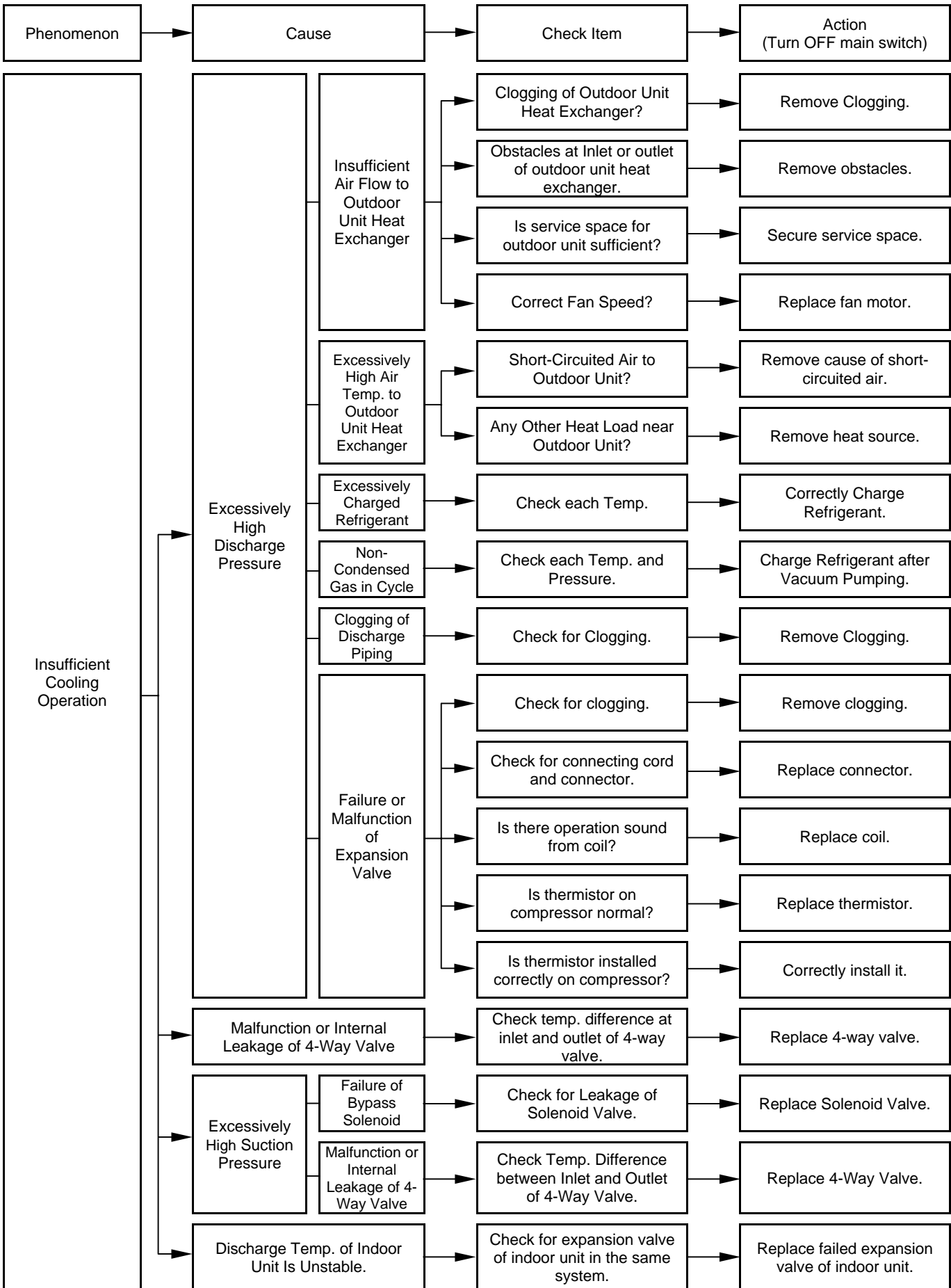

1.1.7 ABNORMALITIES OF DEVICES (Cont.)

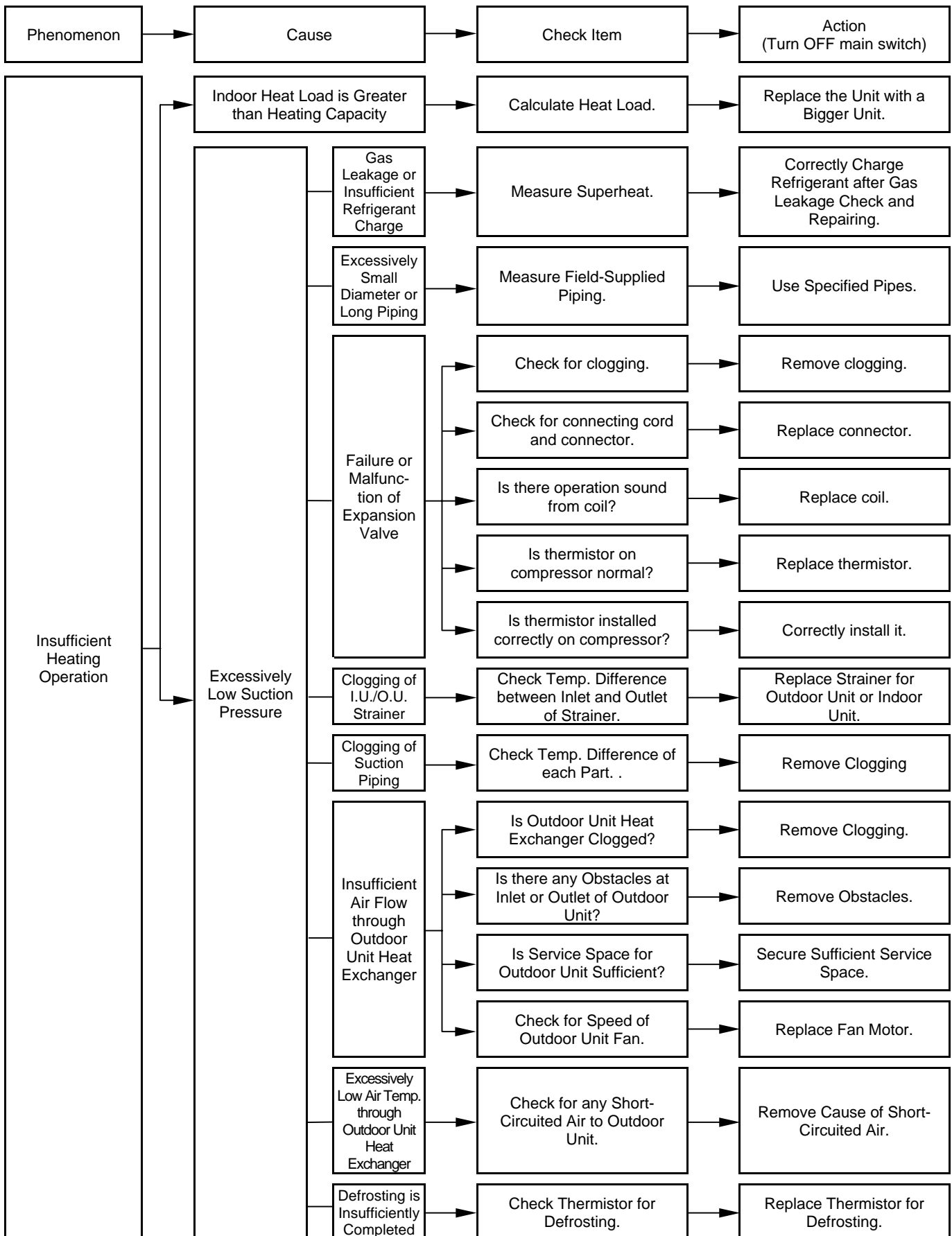

1.1.7 ABNORMALITIES OF DEVICES (Cont.)

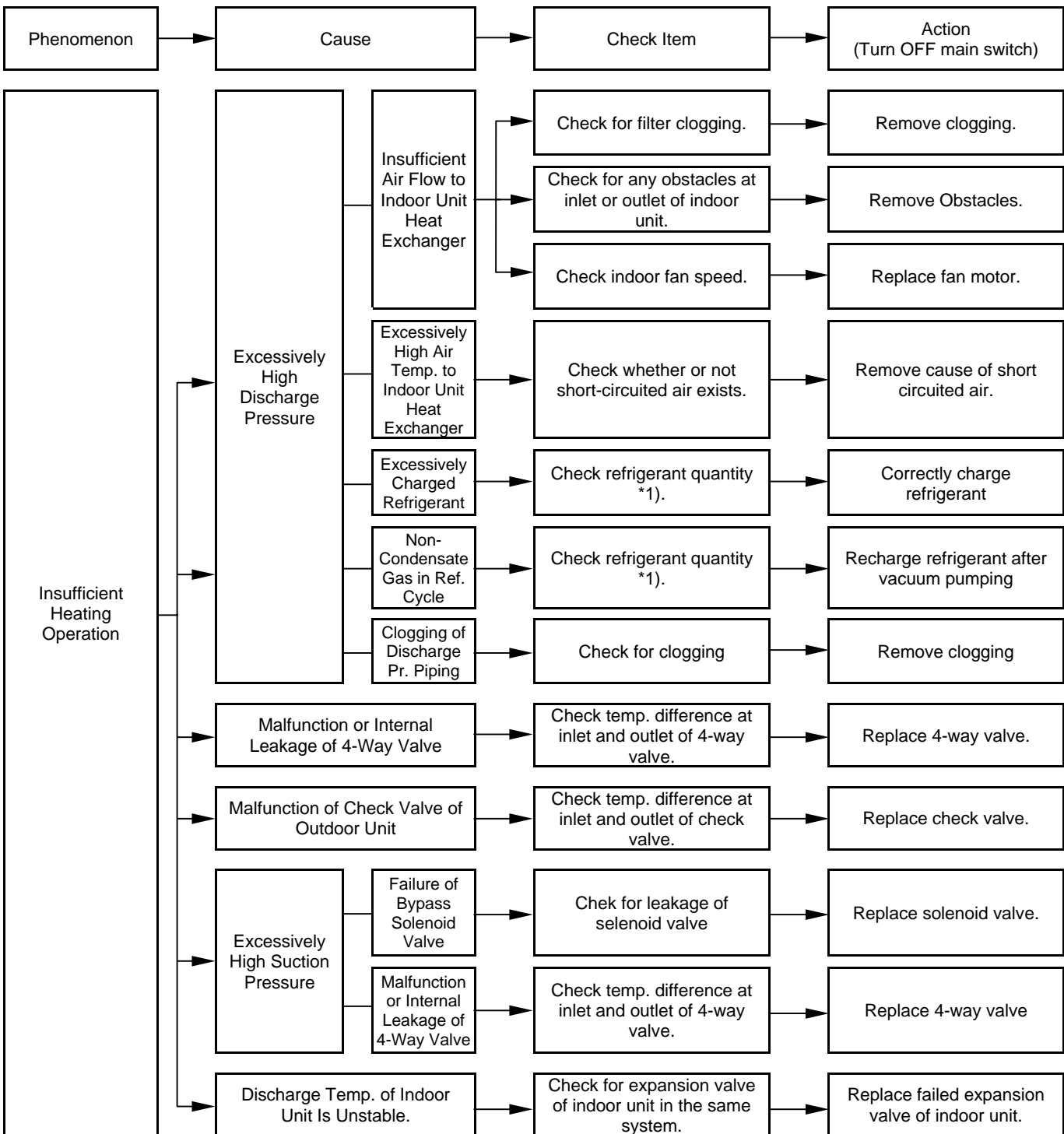

*1): Refer to Item 16.6 of TC

1.1.7 ABNORMALITIES OF DEVICES (Cont.)

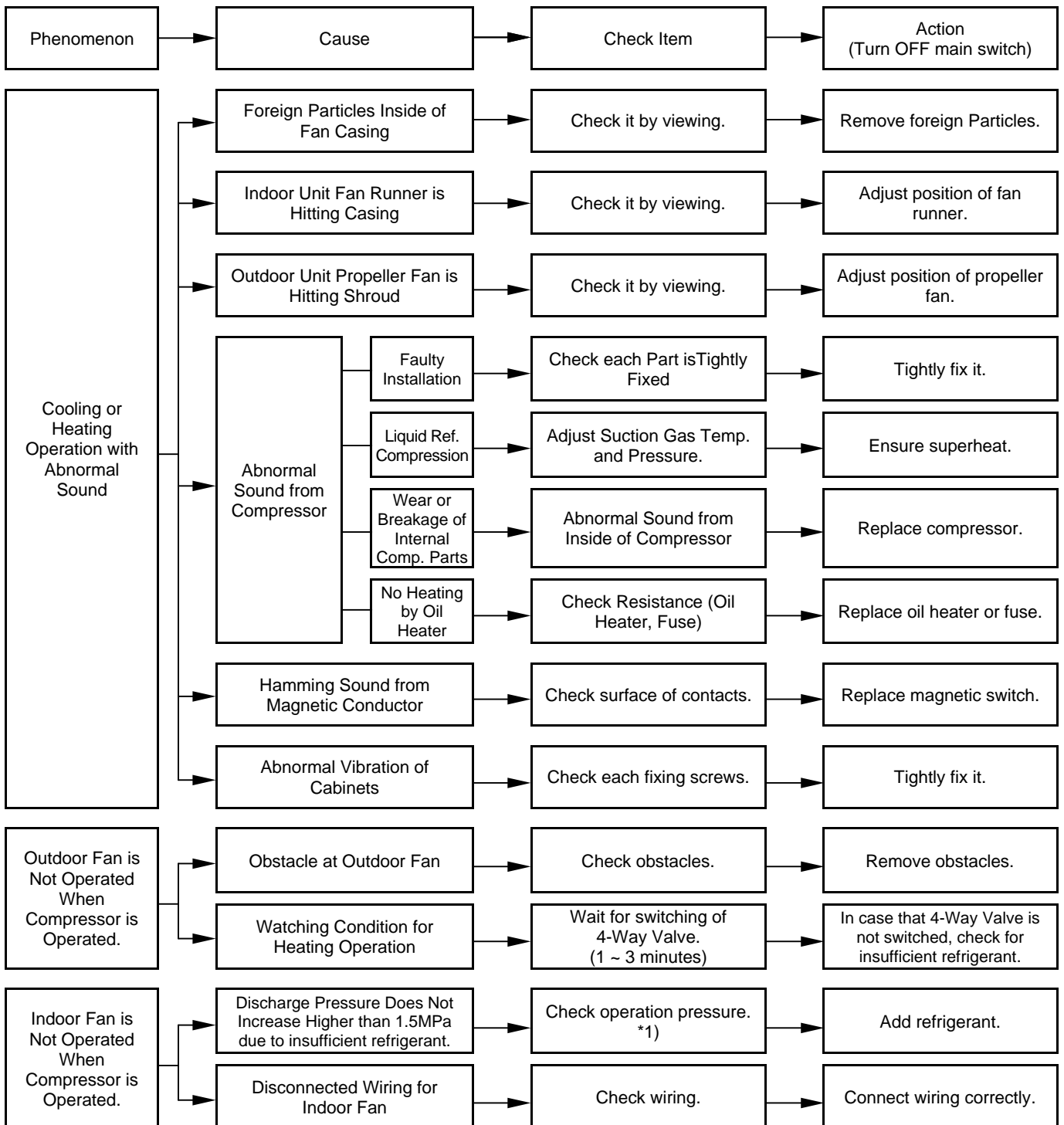

*1): Refer to Item 16.6 of TC

1.2 TROUBLESHOOTING PROCEDURE

1.2.1 ALARM CODE TABLE

Code No.	Category	Content of Abnormality	Leading Cause
01	Indoor Unit	Tripping of Protection Device	Failure of Fan Motor, Drain Discharge, PCB, Relay.
02	Outdoor Unit	Tripping of Protection Device	Activation of PSH
03	Transmission	Abnormality between Indoor and Outdoor (or Indoor)	Incorrect Wiring. Failure of PCB. Tripping of Fuse. Power Supply Off
04	Inverter	Abnormality between Inverter and Control PCB	Failure in Transmission between PCBs.
05	Transmission	Abnormality of Power Source Wiring	Reverse Phase Incorrect Wiring.
06	Voltage Drop	Voltage Drop by Excessively Low or High Voltage to Outdoor Unit	Voltage Drop of Power Supply, Incorrect Wiring or insufficient Capacity or Power Supply Wiring.
07	Cycle	Decrease in Discharge Gas Superheat	Excessive Refrigerant Charge. Expansion Valve Open Lock
08		Increase in Discharge Gas Temperature	Insufficient Refrigerant. Ref- Leakage, Clogging or Expansion Valve Close Lock.
09	Outdoor Unit	Tripping of Protection Device	Failure of Fan Motor.
11	Sensor on Indoor Unit	Inlet Air Thermistor	Failure of Thermistor, Sensor, Connection.
12		Outlet Air Thermistor	
13		Freeze Protection Thermistor	
14		Gas Piping Thermistor	
19		Tripping of Protection Device for Fan Motor	Failure of Fan Motor.
21	Sensor on Outdoor Unit	High Pressure Sensor	Failure of Thermistor, Sensor, Connection
22		Outdoor Air Thermistor	
23		Discharge Gas Thermistor on Comp.	
24		Evaporating Thermistor	
29		Low Pressure Sensor	
31	System	Incorrect Setting of Outdoor and Indoor Unit	Incorrect Setting of Capacity Code.
32		Abnormal Transmission of Other Indoor Unit	Failure of Power Supply, PCB in Other Indoor Unit. Failure of Other Indoor Unit of the same refrigerant cycle
35		Incorrect Setting in Indoor/Outdoor Unit No.	Existence of the same Indoor Unit No. in the same refrigerant cycle
38		Abnormality of Protective Circuit in Outdoor Unit	Failure of Indoor Unit PCB. Incorrect Wiring Connection to PCB in Outdoor Unit.
39		Abnormality of Running Current at Constant Compressor	Overcurrent, Melted Fuse or failure of current sensor.
43	Pressure	Pressure Ratio Decrease Protection Activating	Failure of Compressor, Inverter.
44		Low Pressure Increase Protection Activating	Overload to Indoor in Cooling. High Temperature of Outdoor Air in Heating. Expansion Valve Open Lock
45		High Pressure Increase Protection Activating	Overload Operation. Excessive Refrigerant. Clogging of Heat Exchanger
46		High Pressure Decrease Protection Activating	Insufficient Refrigerant.
47		Low Pressure Decrease Protection Activating	Insufficient Refrigerant. Expansion valve Close Lock. Refrigerant Leakage.
51	Inverter	Abnormality of Current Sensor for Inverter	Failure of Sensor on Inverter PCB
52		Overcurrent Protection Activating	Overload, Overcurrent, Locking to Compressor.
53		IPM Protection Activating	Automatic Stoppage of IPM (Overcurrent, Low Voltage or Overheating).
59	AC Chopper	AC Chopper Circuit Protection	Failure of FET, Power Supply, CT for Fan Motor
EE	Inverter	Compressor Protection	3 Time Occurrence of Alarm Giving Damage to Compressor within 6 hours
dd	Transmission	Incorrect Wiring between Indoor Units	Incorrect Wiring between Indoor Units and Remote Control Switch

1.2.2 TROUBLESHOOTING BY ALARM CODE

Alarm Code	
01	Activation of Safety Device in Indoor Unit

- "RUN" light flickers and "ALARM" is indicated on the remote control switch.
- The unit No., alarm code and the unit code is alternately indicated on the set temperature section, and the unit No. and alarm code are indicated on the display of the outdoor unit PCB.
- ★ This alarm code is indicated when the contact between #1 and #2 of CN14 is not closed over 120 seconds during the cooling, fan or heating operation.

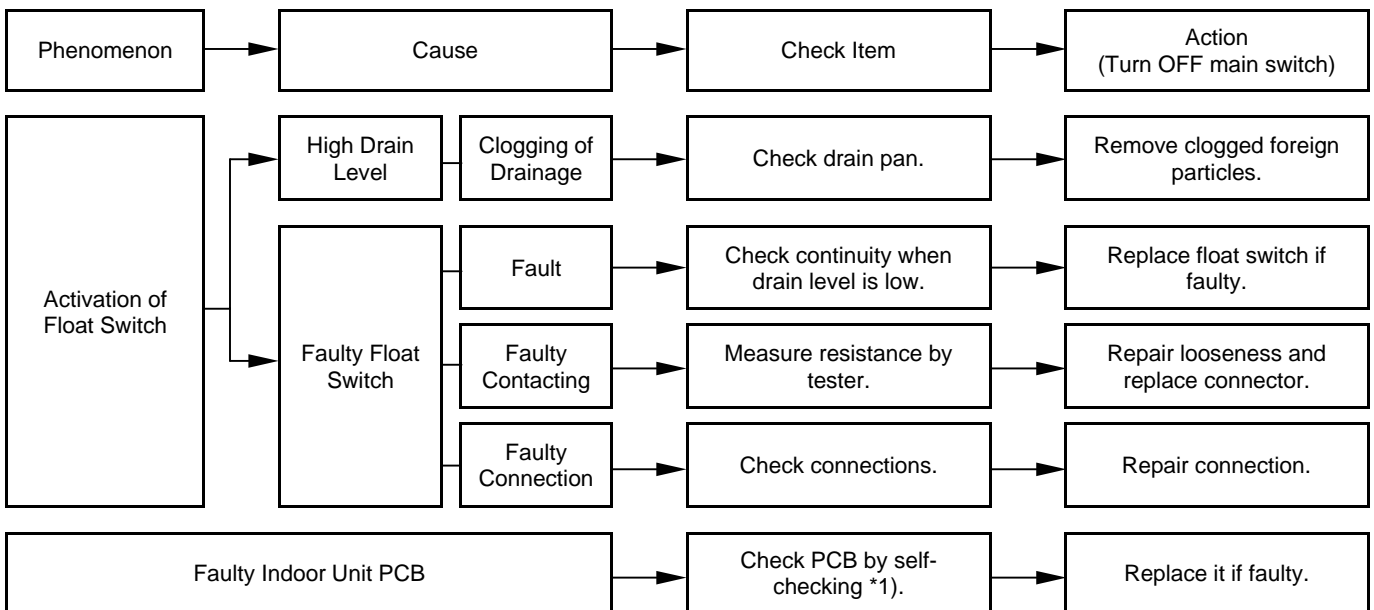
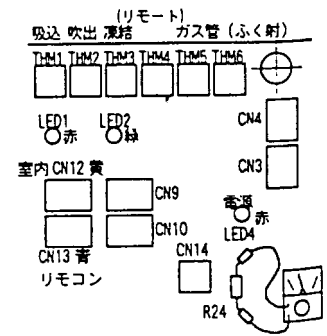
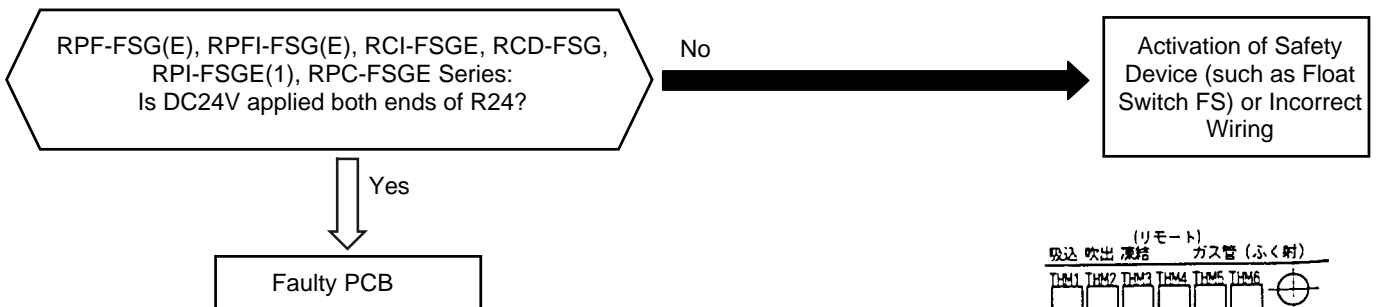

*1): Refer to Item 1.3.1 and 1.3.3.
Alarm code 01" is not indicated at RPK series.

Alarm Code	Activation of Safety Device in Outdoor Unit
02	

- "RUN" light flickers and "ALARM" is indicated on the remote control switch.
- The unit No., alarm code and the unit code is alternately indicated on the set temperature section, and the unit No. and alarm code are indicated on the display of the outdoor unit PCB.
- ★ This alarm is indicated when one of safety devices is activated during compressor running.

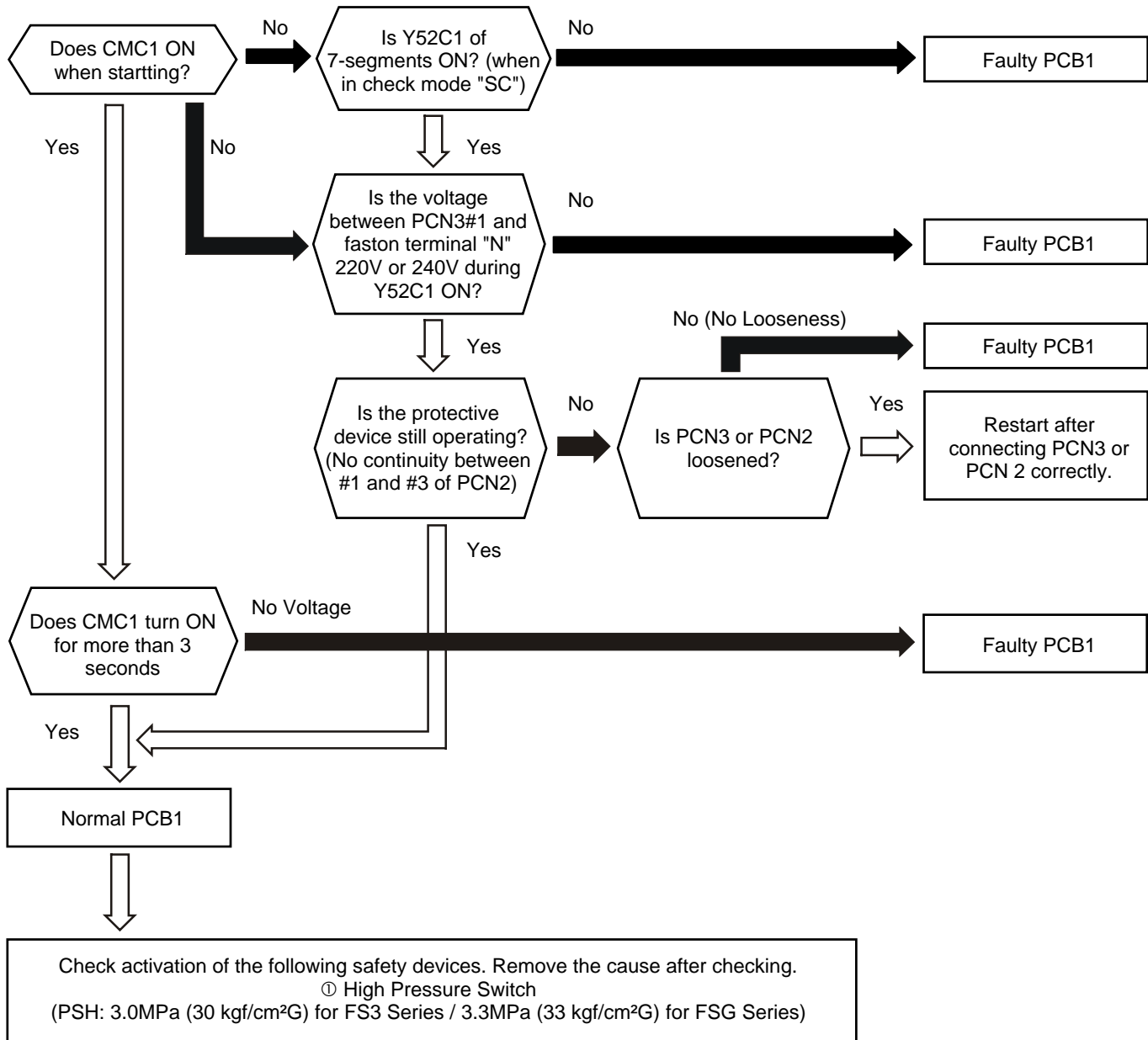

Check Item		
Power Supply	Connector for CMC1	Faston Terminal
380-415V 50Hz	PCN3	N

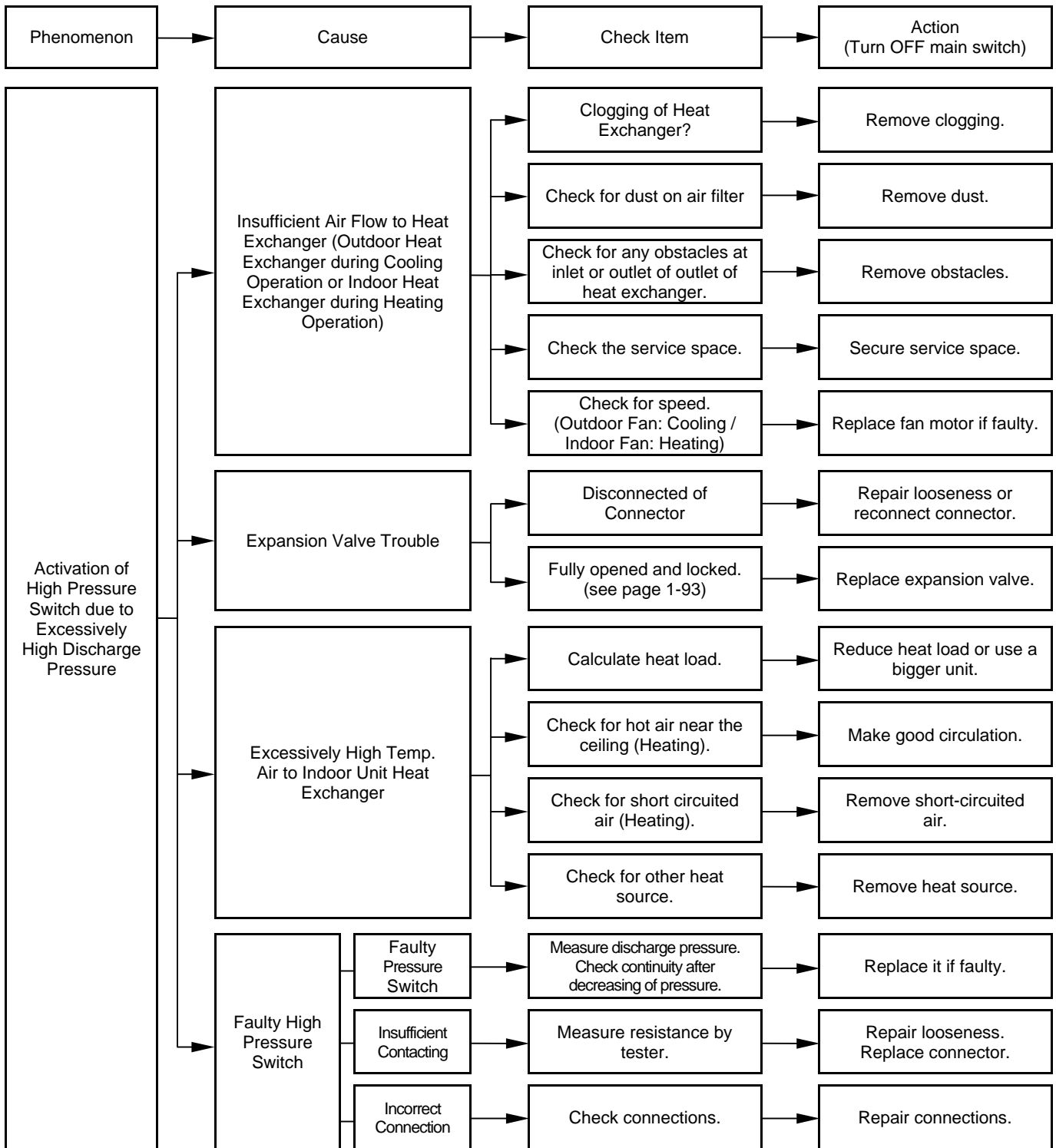

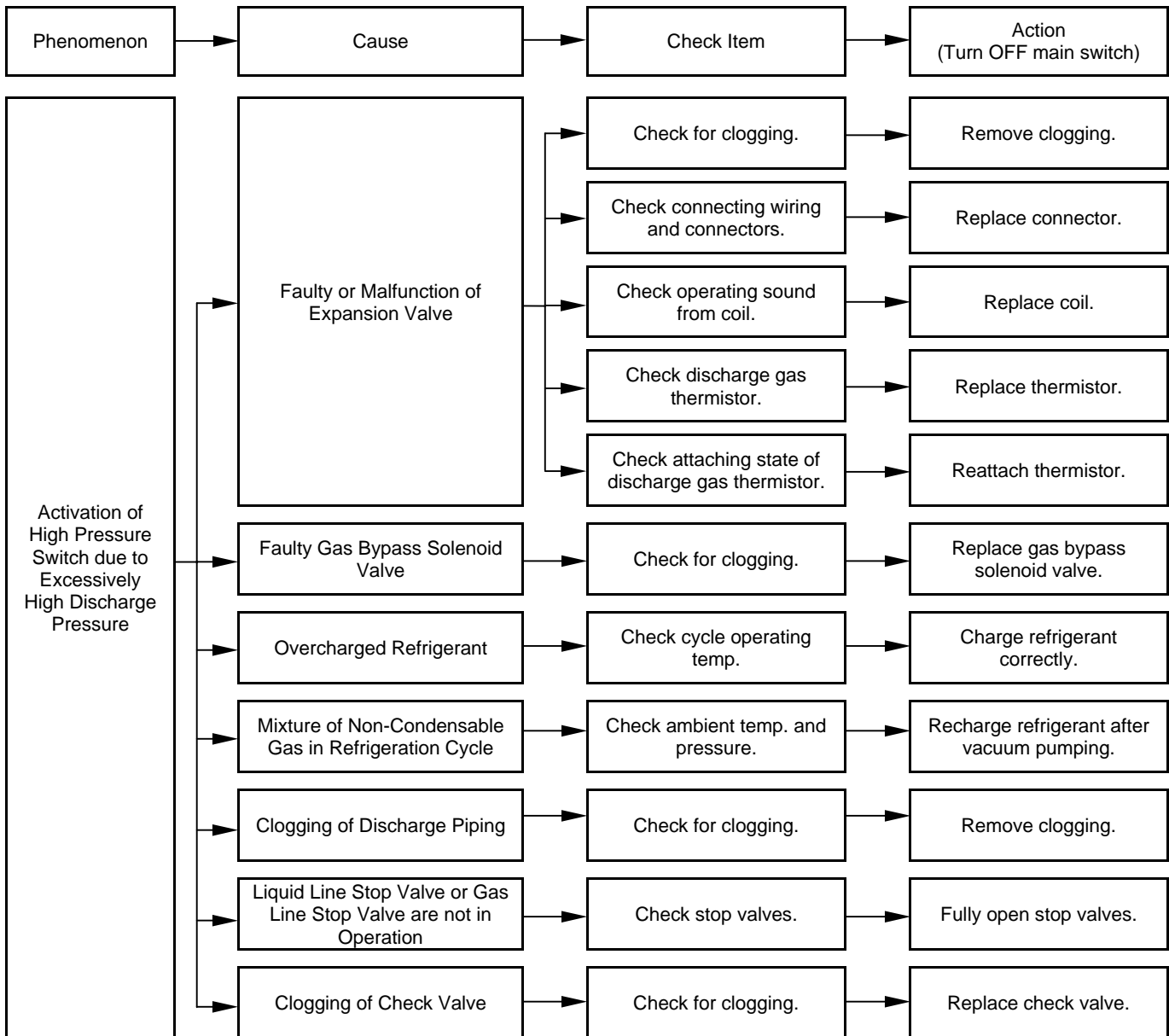

Alarm Code	Abnormal Transmitting between Indoor Units and Outdoor Unit
03	

- "RUN" light flickers and "ALARM" is indicated on the remote control switch.
- The unit No., alarm code and the unit code is alternately indicated on the set temperature section, and the unit No. and alarm code are indicated on the display of the outdoor unit PCB.
- ★ This alarm is indicated when abnormality is maintained for 3 minutes after normal transmitting between indoor units and outdoor unit, and also abnormality is maintained for 30 seconds after the micro-computer is automatically reset.
The alarm is indicated when the abnormal transmitting is maintained for 30 seconds from starting of the outdoor unit.
- ★ Investigate the cause of overcurrent and take necessary action when fuses are melted or the breaker for the outdoor unit are activated.

(See next page)

Note from next page:

- *1) In case that terminal resistance (DSW10-1P) is OFF when H-Link Connection is performed.
Set the terminal resistance to ON when CN2 is removed.
Set the terminal resistance to OFF when CN2 is reconnected.

Check Item	
Power Supply	FastonTerminal
380-415V 50Hz	between R1 and N

*2) PCB1 factory Setting for Non-pole Transmitting

item	Setting Position
SW1	Left side (New transmission side)
JP1	Short Circuit
CN2	Transmission Wire Connecting
CN18	NBon-Occupied

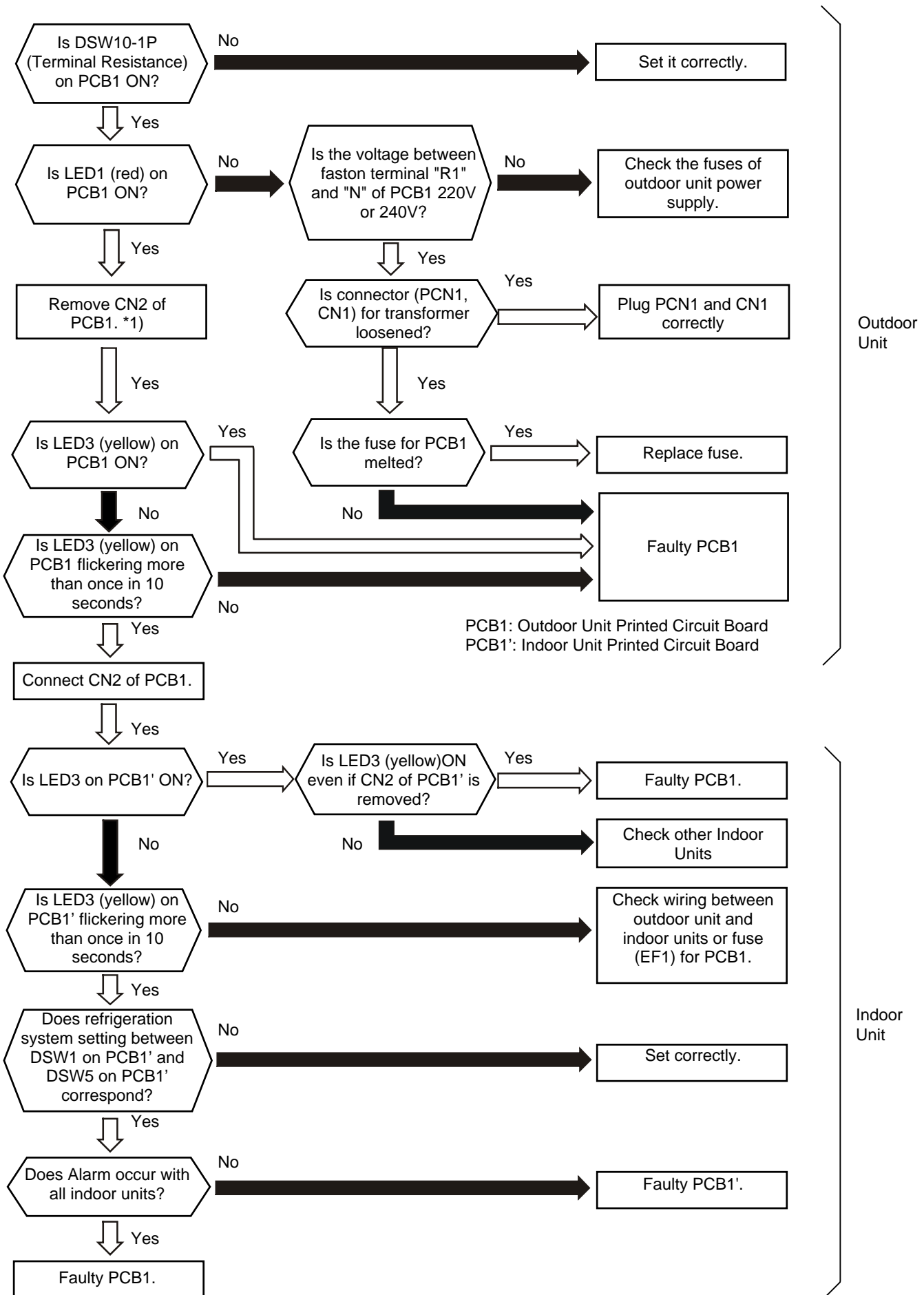



Alarm Code	Abnormal Transmitting between Inverter and Outdoor PCB1,3
04	

- "RUN" light flickers and "ALARM" is indicated on the remote control switch.
- The unit No., alarm code and the unit code is alternately indicated on the set temperature section, and the unit No. and alarm code are indicated on the display of the outdoor unit PCB1.
- ★ This alarm is indicated when abnormality is maintained for 30 seconds after normal transmitting between the outdoor unit PCB1 and inverter PCB3, and also abnormality is maintained for 30 seconds after the micro-computer is automatically reset. The alarm is indicated when the abnormal transmitting is maintained for 30 seconds from starting of the outdoor unit.

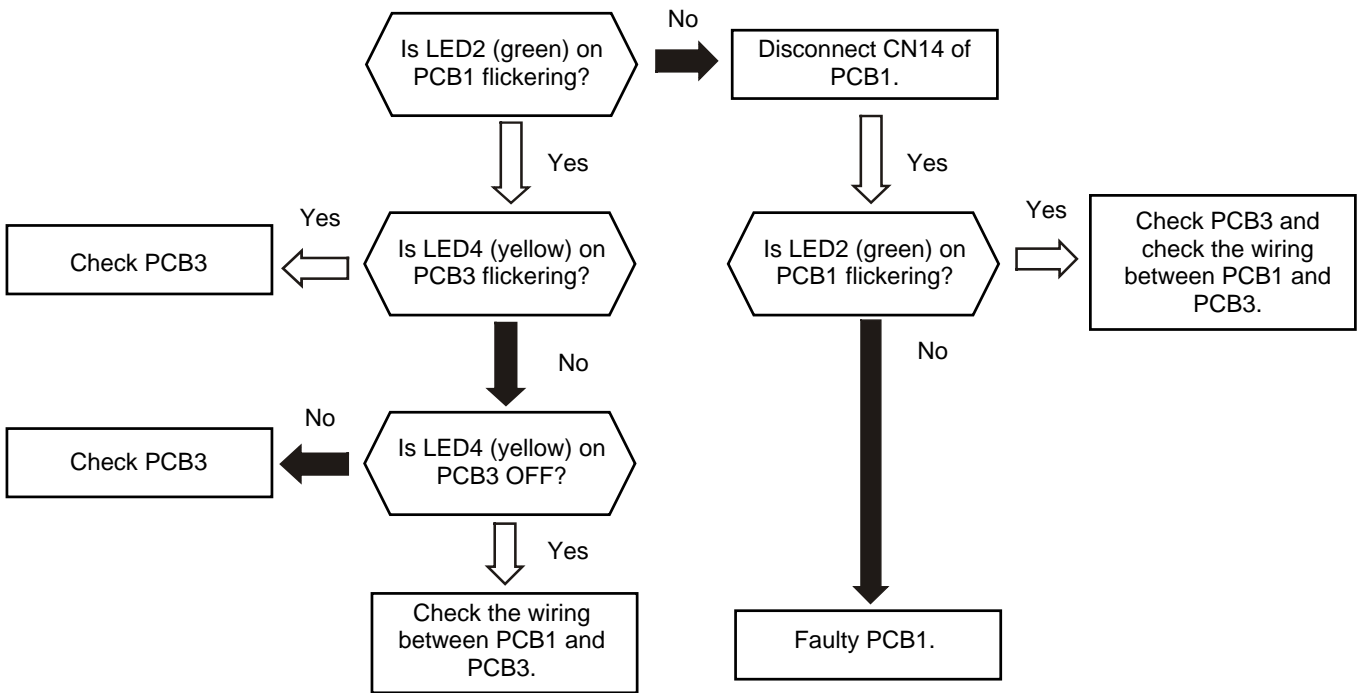

PCB1: Control PCB in Outdoor Unit
 PCB3: Inverter PCB (High Voltage)

Phenomenon	Cause	Check Item	Action (Turn OFF main switch)
Disconnected Wires, Insufficient Contacting or Incorrect Connection	Between Control PCB and Inverter PCB	Check continuity of wires. Check for looseness of connection screws. Check connection No.	Replacing Wires, Repairing, Tightening Screws and Incorrect Wiring.
	Power Source Wiring for Outdoor Unit		
Faulty PCB (PCB1 for Control, PCB3 for Inverter)	Disconnected Wires to PCB	Check connections.	Repair wiring connections.
	Faulty PCB		Replace PCB if faulty.
Incorrect Wiring	Disconnected Wires Insufficient Contacting	Check continuity. Check for looseness of connection screws.	Replacing Wires, Repairing, Tightening Screws
	Incorrect Wiring	Check connection Nos.	Correct connect Wires.

Alarm Code	Code Abnormality of Picking up Phase Signal
05	

- "RUN" light flickers and "ALARM" is indicated on the remote control switch.
- The unit No., alarm code and the unit code is alternately indicated on the set temperature section, and the unit No. and alarm code are indicated on the display of the outdoor unit PCB.
- ★ This alarm is indicated when the main power source phase is reversely connected or one phase is not connected.

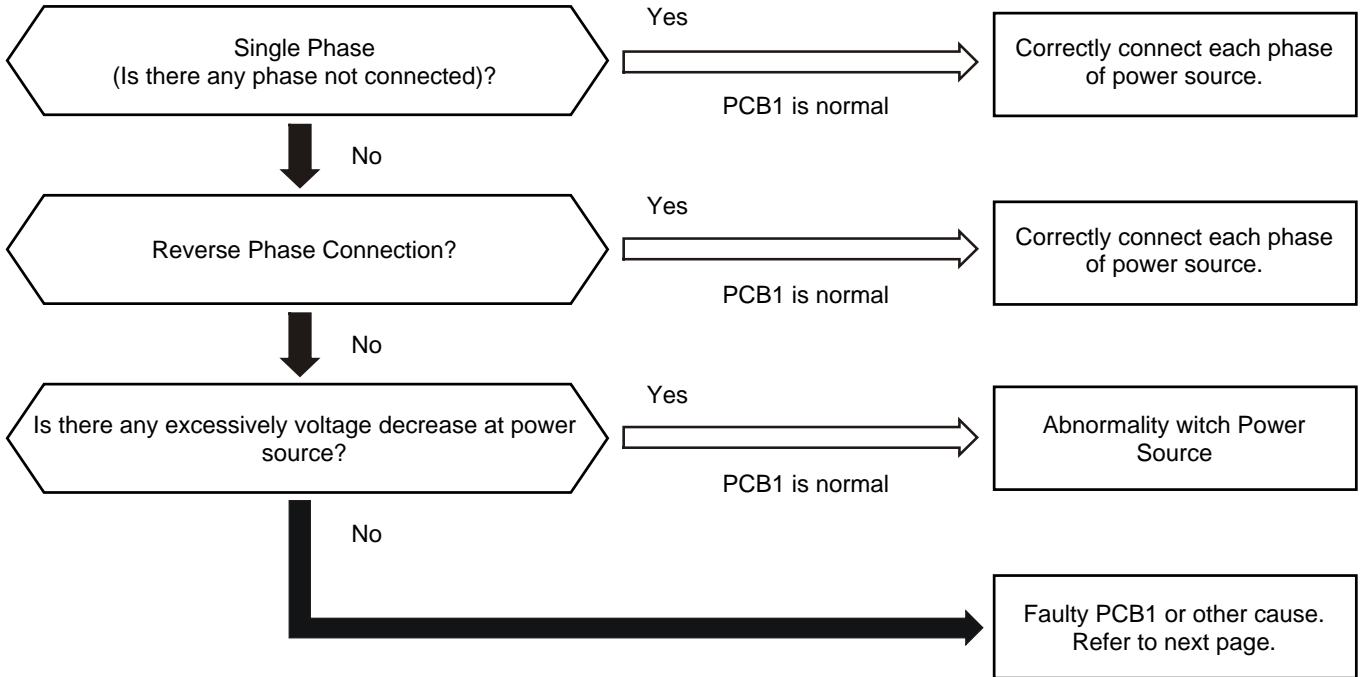

Note: PCB1: Outdoor Unit Printed Circuit Boaed.

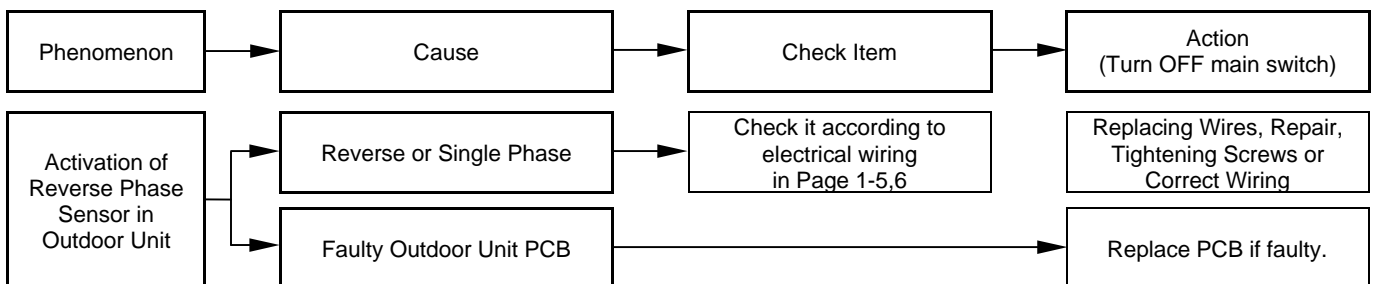
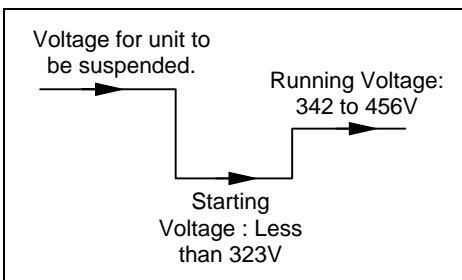

Alarm Code	06	Excessively Low or High Voltage for Inverter
------------	-----------	-----------------------------------------------------

- "RUN" light flickers and "ALARM" is indicated on the remote control switch.
- The unit No., alarm code and the unit code is alternately indicated on the set temperature section, and the unit No. and alarm code are indicated on the display of the outdoor unit PCB.
- ★ This alarm code is indicated when voltage between terminal "P" and "N" of transistor module (IPM) is insufficient and its occurrence is three times in 30 minutes. In the case that the occurrence is smaller than 2 times, retry is performed.

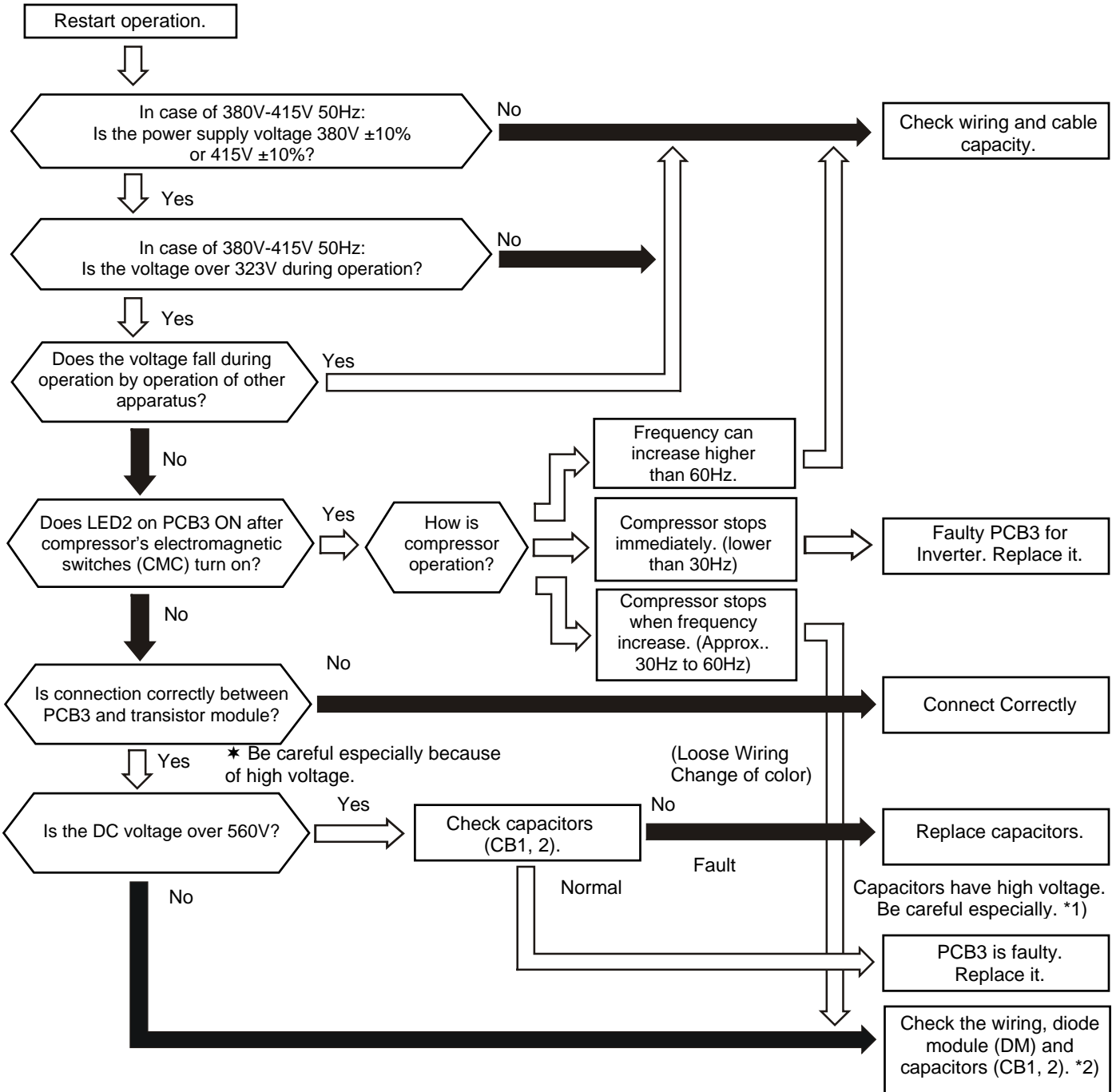

*1): If capacitor has high voltage, perform the high voltage discharge work refer to item 1.3.6.

*2): Checking procedures of diode module is indicated in item 1.3.6.

*3): DC voltage measuring position:

IPM "P" Terminal to "+" Terminal of Tester, "N" Terminal to "-" Terminal of Tester Measuring Position: DC 1000V

Alarm Code	Decrease of Discharge Gas Superheat
07	

- "RUN" light flickers and "ALARM" is indicated on the remote control switch.
- The unit No., alarm code and the unit code is alternately indicated on the set temperature section, and the unit No. and alarm code are indicated on the display of the outdoor unit PCB.
- ★ In the case that the discharge gas superheat less than 10 deg. at the top of the compressor is maintained for 30 minutes, retry operation is performed. However, when the alarm occurs again within 90 minutes, this alarm code is indicated.

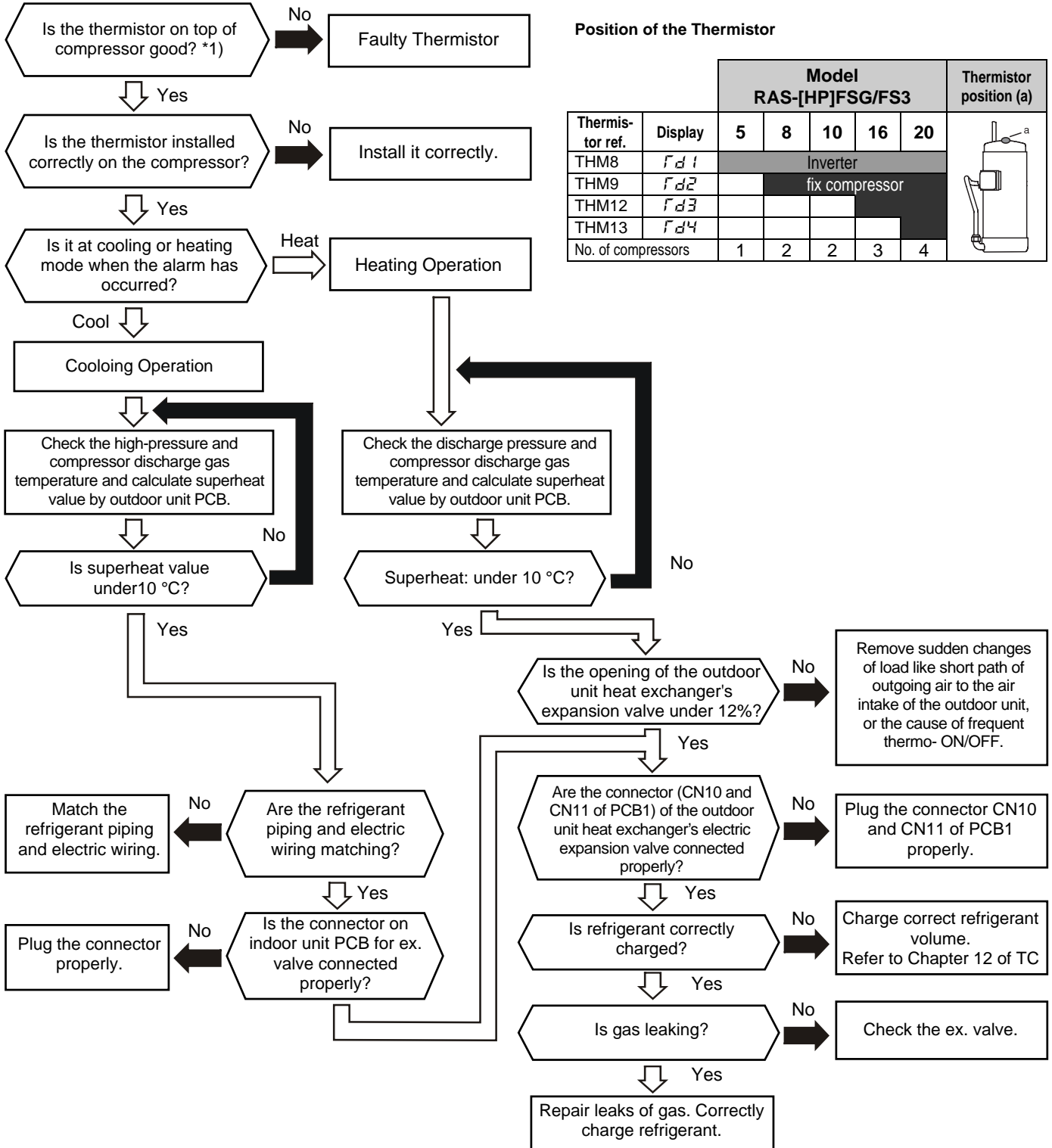

*1): Refer to "Characteristics of Thermistor" of page 1-42.

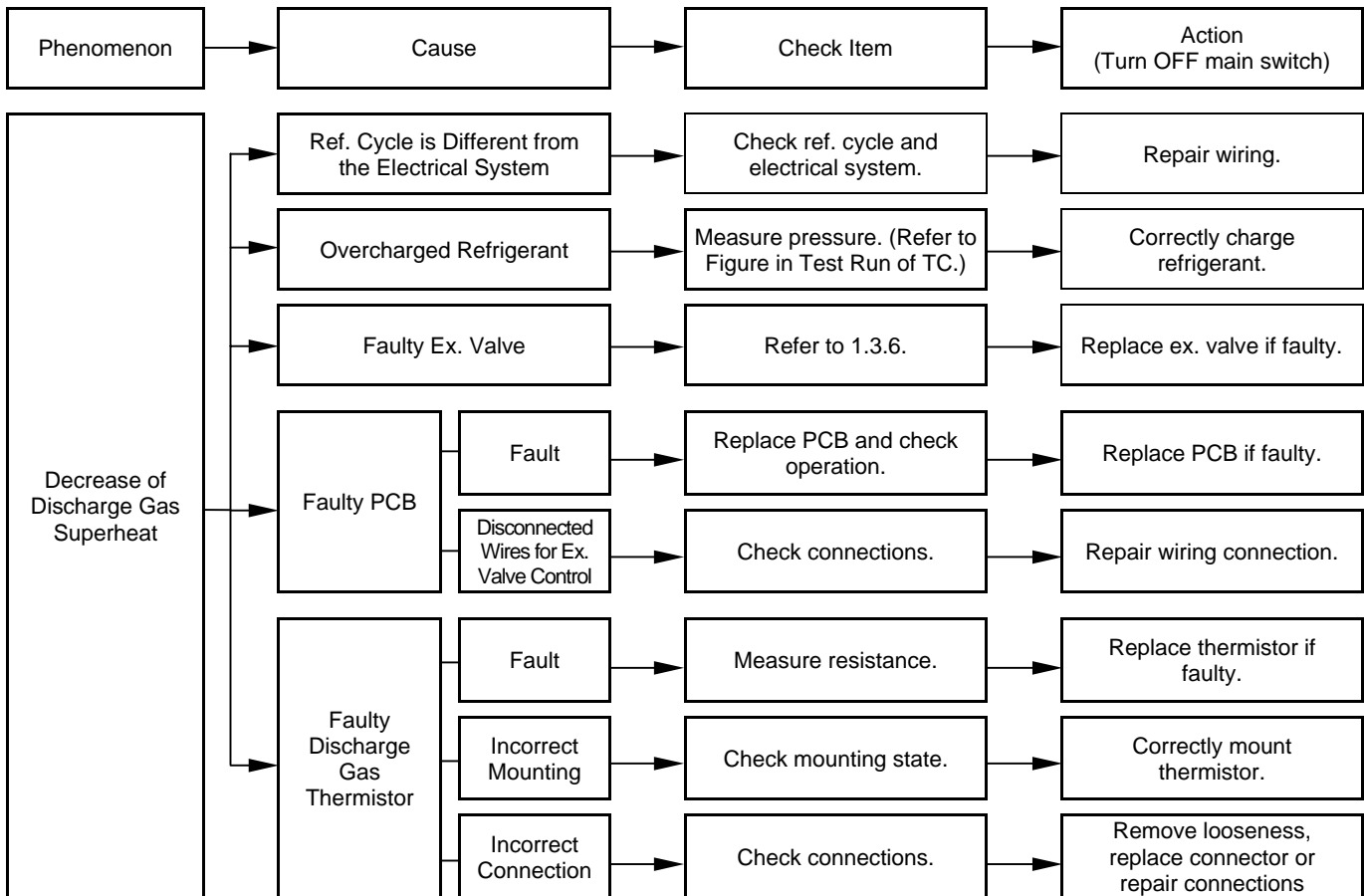

Alarm Code	08	Excessively High Discharge Gas Temperature at the Top of Compressor Chamber
------------	-----------	------------------------------------------------------------------------------------

- "RUN" light flickers and "ALARM" is indicated on the remote control switch.
- The unit No., alarm code and the unit code is alternately indicated on the set temperature section, and the unit No. and alarm code are indicated on the display of the outdoor unit PCB.
- ★ This alarm is indicated when the following conditions occurs three times within one hour:
 - (1) The temperature of the thermistor on the top of the compressor is maintained higher than 132 °C for 10 minutes, or
 - (2) The temperature of the thermistor on the top of the compressor is maintained higher than 140 °C for 5 seconds.

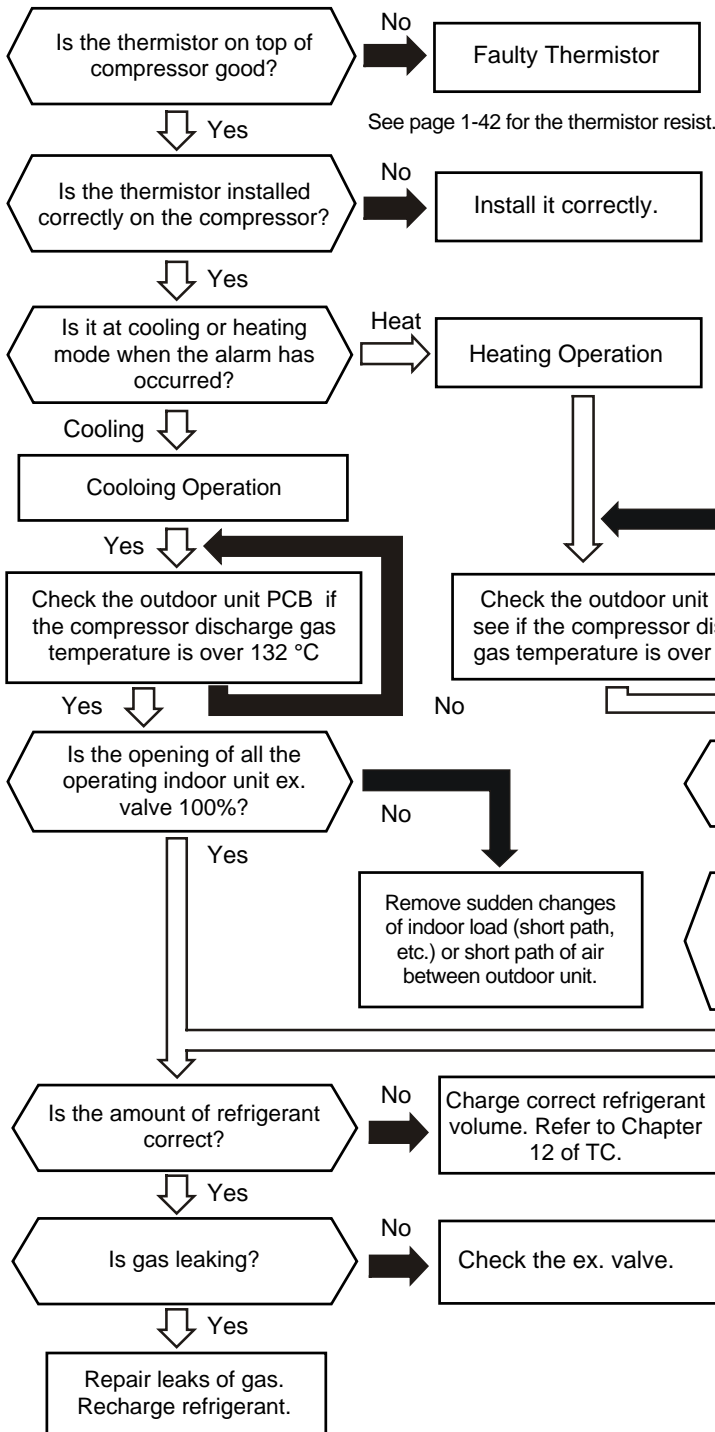

Position of the Thermistor

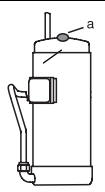
		Model RAS-[HP]FSG/FS3					Thermistor position (a)
Thermis- tor ref.	Display	5	8	10	16	20	
THM8	Fd1	Inverter					
THM9	Fd2	fix compressor					
THM12	Fd3						
THM13	Fd4						
No. of compressors		1	2	2	3	4	

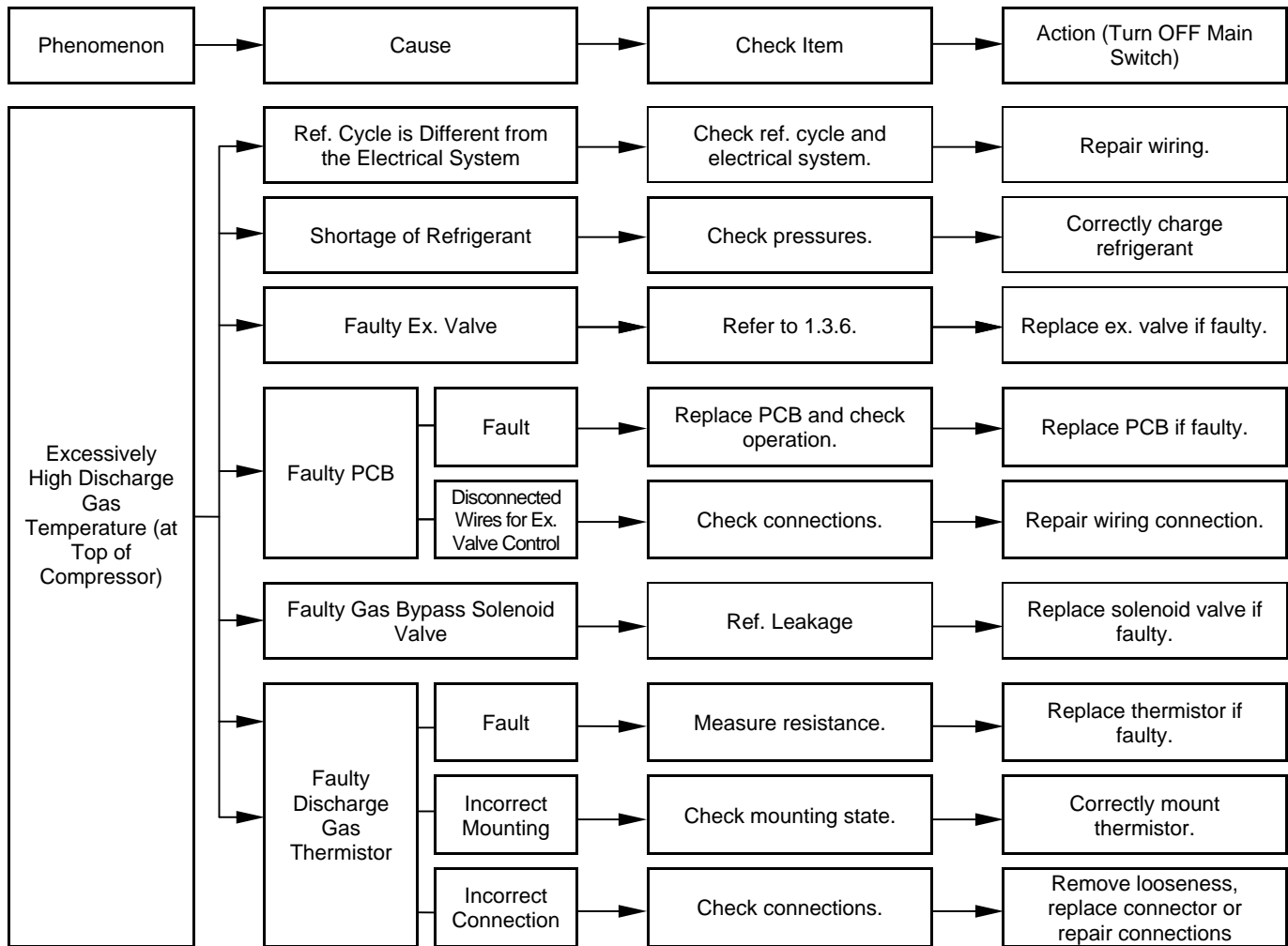

Alarm Code	09	Activation of Protection Device for Outdoor Fan Motor
------------	-----------	--------------------------------------------------------------

- "RUN" light flickers and "ALARM" is indicated on the remote control switch.
- The unit No., alarm code and the unit code is alternately indicated on the set temperature section, and the unit No. and alarm code are indicated on the display of the outdoor unit PCB.
- ★ This alarm code is indicated when the temperature of the internal thermostat (ITO1, 2) for the outdoor fan motor is higher than 130 °C

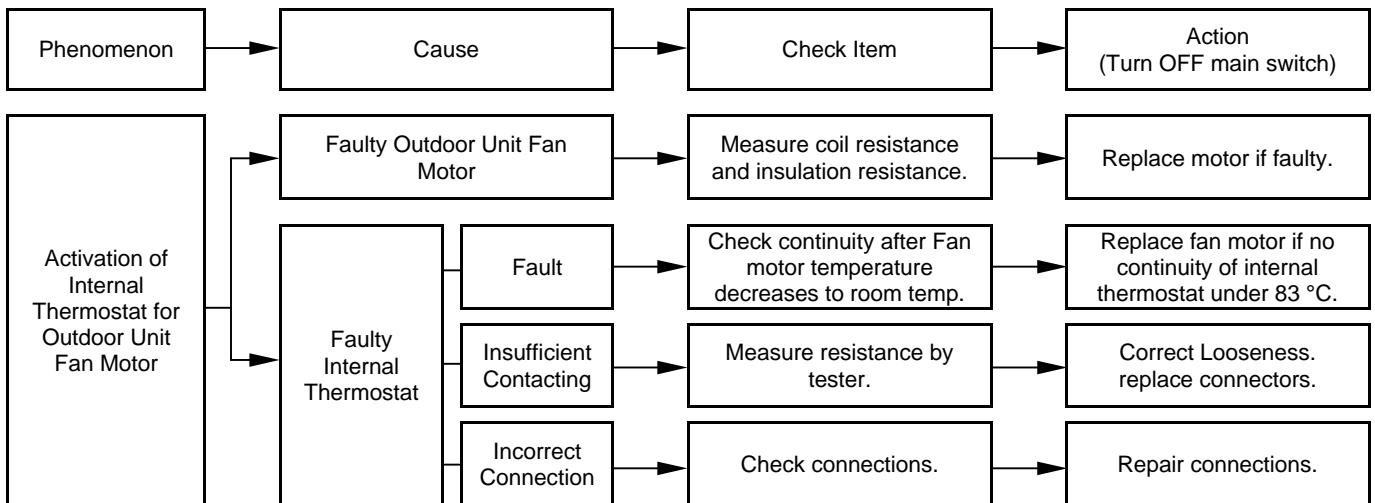
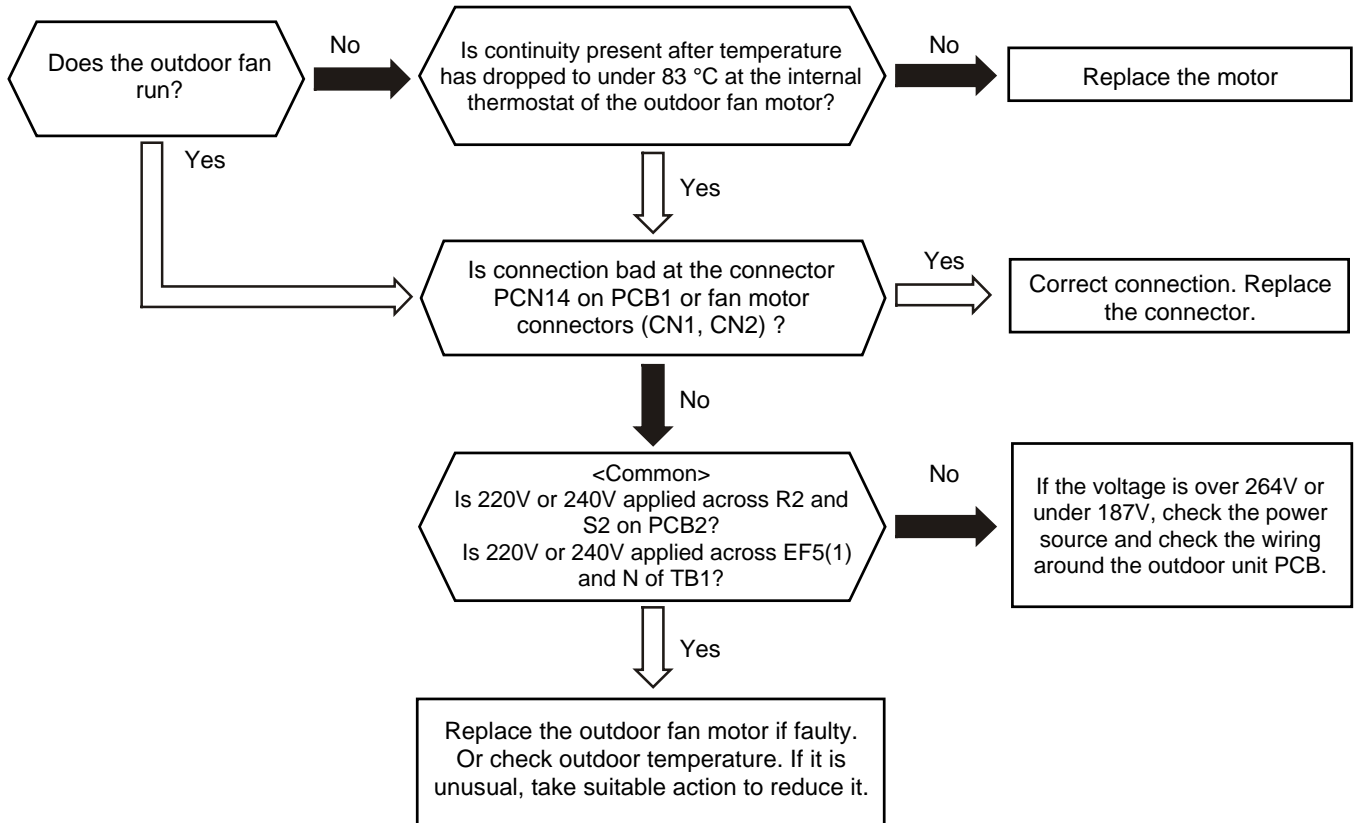

Alarm Code 11	Abnormality of Thermistor for Indoor Unit Inlet Air Temperature (Air Inlet Thermistor)
-------------------------	---------------------------------------------------------------------------------------------------

- "RUN" light flickers and "ALARM" is indicated on the remote control switch.
- The unit No., alarm code and the unit code is alternately indicated on the set temperature section, and the unit No. and alarm code are indicated on the display of the outdoor unit PCB.
- ★ This alarm code is indicated when the thermistor is short-circuited (less than 0.24 kΩ) or cut (greater than 840 kΩ) during the cooling or heating operation. The system is automatically restarted when the fault is removed.

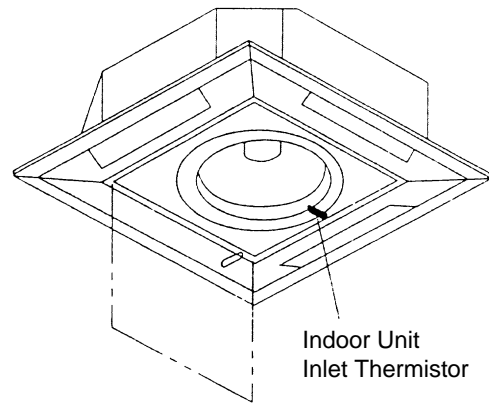
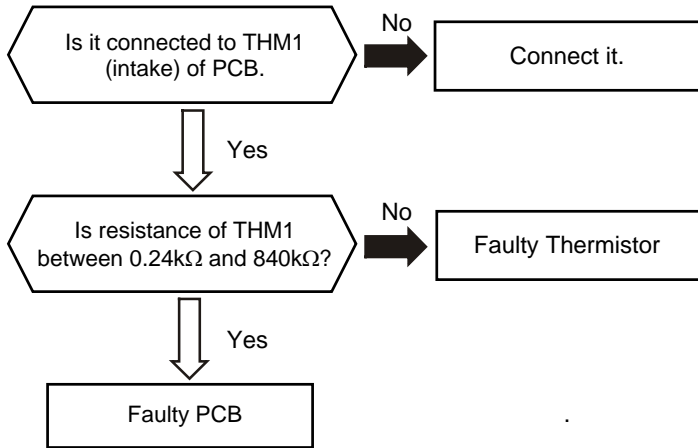

In case of 4-Way Cassette

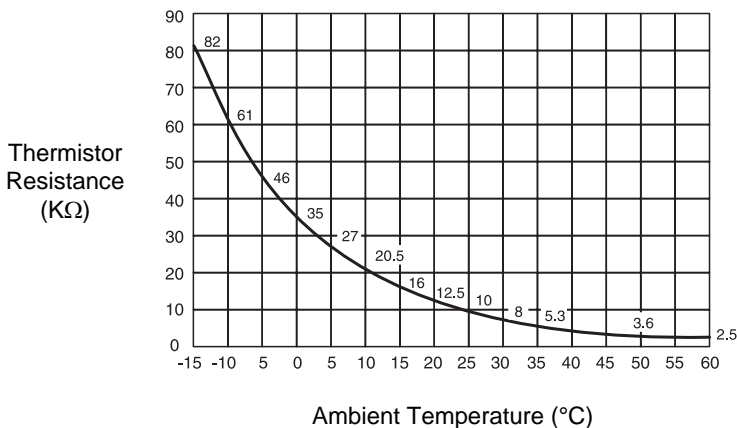
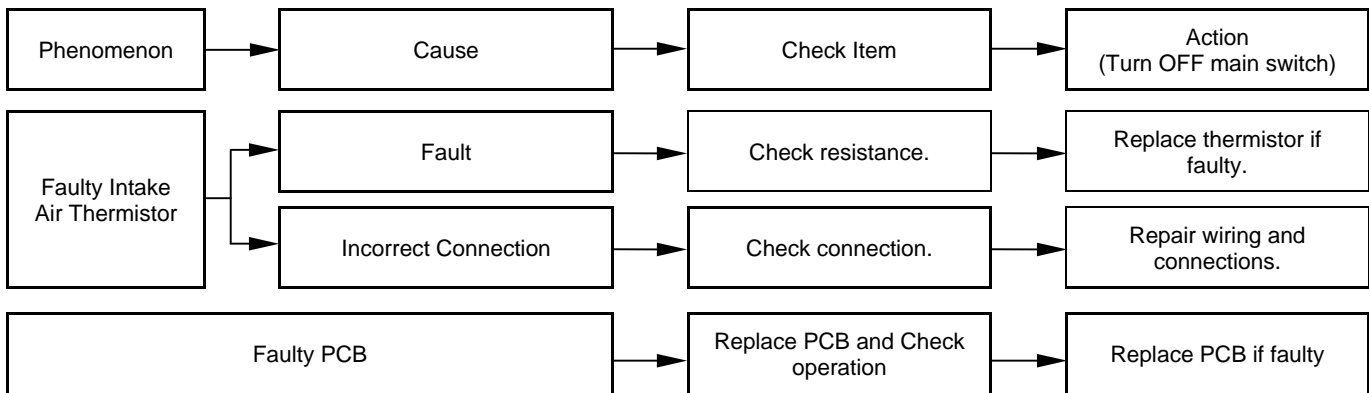

Thermistor Characteristics

- Note:** This data is applicable to the following thermistors:
1. Indoor Unit Discharge Air Temperature,
 2. Indoor Unit Liquid Refrigerant Temperature
 3. Indoor Unit Intake Air Temperature
 4. Outdoor Air Temperature
 5. Outdoor Unit Evaporating Temperature
 6. Indoor Unit Gas Piping

<table border="1" style="width: 100%; border-collapse: collapse;"> <tr> <td style="text-align: center; font-weight: bold;">Alarm Code</td> </tr> <tr> <td style="text-align: center; font-size: 2em; font-weight: bold;">12</td> </tr> </table>	Alarm Code	12	<h3 style="margin: 0;">Abnormality of Thermistor for Indoor Discharge Air Temperature (Air Outlet Thermistor)</h3>
Alarm Code			
12			

- "RUN" light flickers and "ALARM" is indicated on the remote control switch.
- The unit No., alarm code and the unit code is alternately indicated on the set temperature section, and the unit No. and alarm code are indicated on the display of the outdoor unit PCB.
- ★ This alarm code is indicated when the thermistor is short-circuited (less than 0.24 kΩ) or cut (greater than 840 kΩ) during the cooling or heating operation. The system is automatically restarted when the fault is removed.

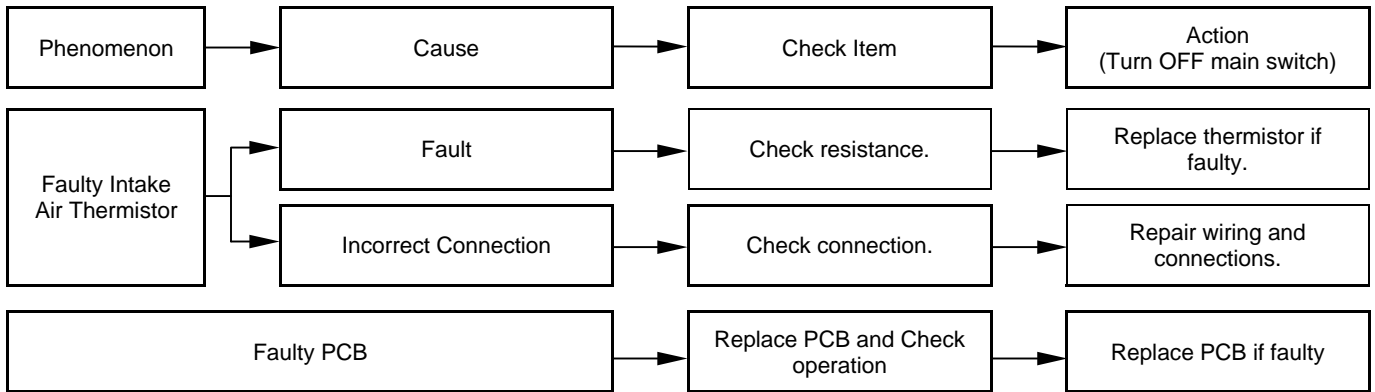
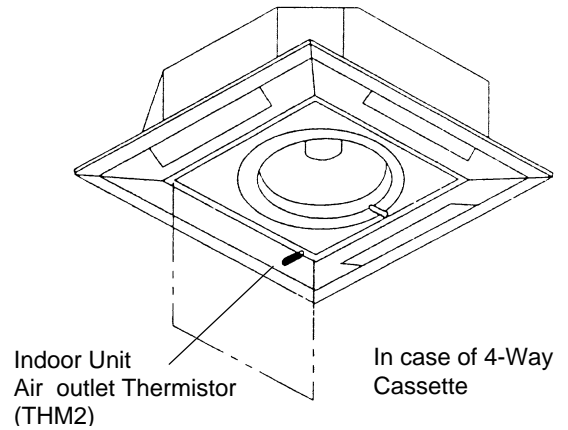
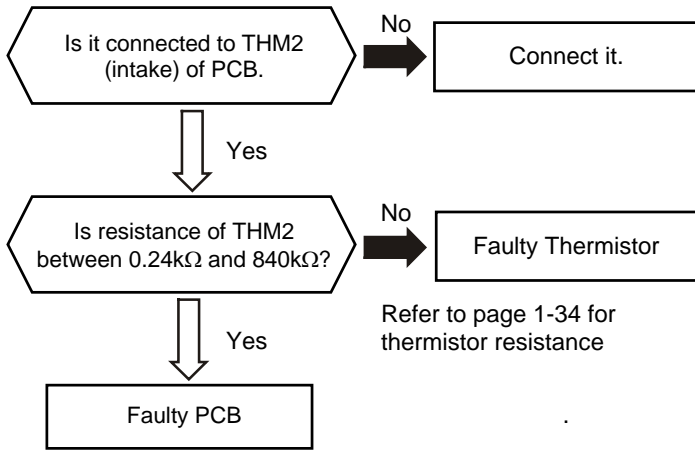

Alarm Code	Abnormality of Thermistor for Indoor Unit Heat Exchanger Liquid Refrigerant Pipe Temperature (Freeze Protection Thermistor)
13	

- "RUN" light flickers and "ALARM" is indicated on the remote control switch.
- The unit No., alarm code and the unit code is alternately indicated on the set temperature section, and the unit No. and alarm code are indicated on the display of the outdoor unit PCB.
- ★ This alarm code is indicated when the thermistor is short-circuited (less than 0.24 kΩ) or cut (greater than 840 kΩ) during the cooling or heating operation. The system is automatically restarted when the fault is removed.

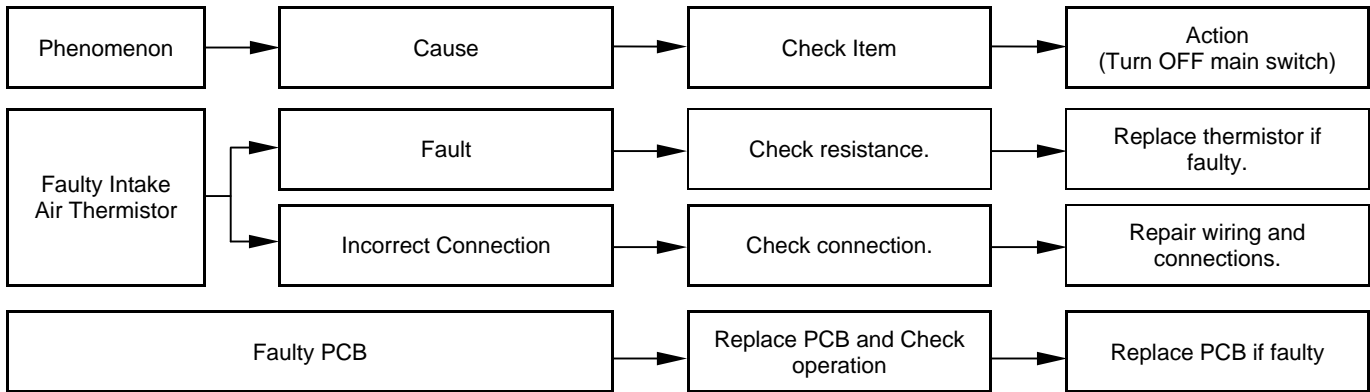
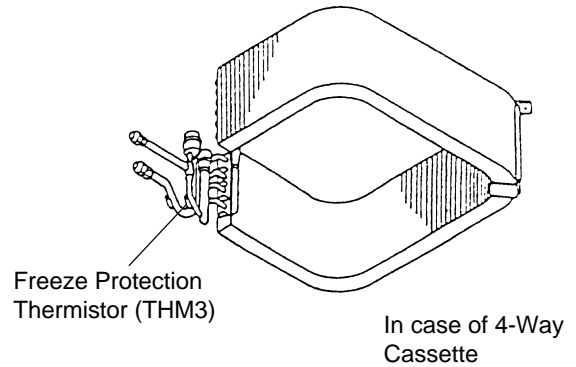
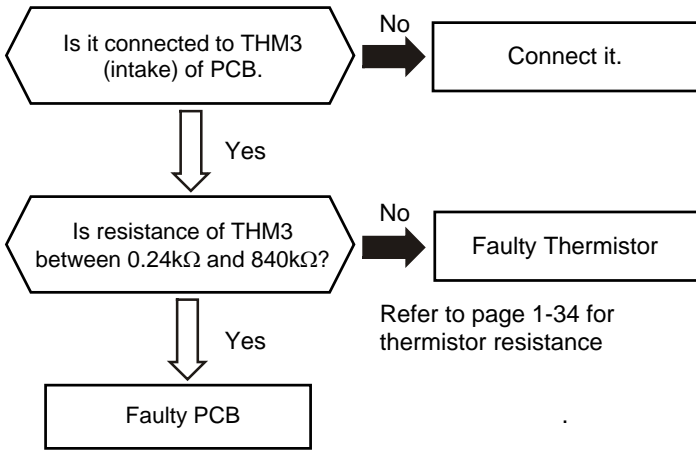

Alarm Code	Abnormality of Thermistor for Indoor Unit Heat Exchanger Gas Refrigerant Pipe Temperature (Gas Piping Thermistor)
14	

- "RUN" light flickers and "ALARM" is indicated on the remote control switch.
- The unit No., alarm code and the unit code is alternately indicated on the set temperature section, and the unit No. and alarm code are indicated on the display of the outdoor unit PCB.
- ★ This alarm code is indicated when the thermistor is short-circuited (less than 0.24 kΩ) or cut (greater than 840 kΩ) during the cooling or heating operation. The system is automatically restarted when the fault is removed.

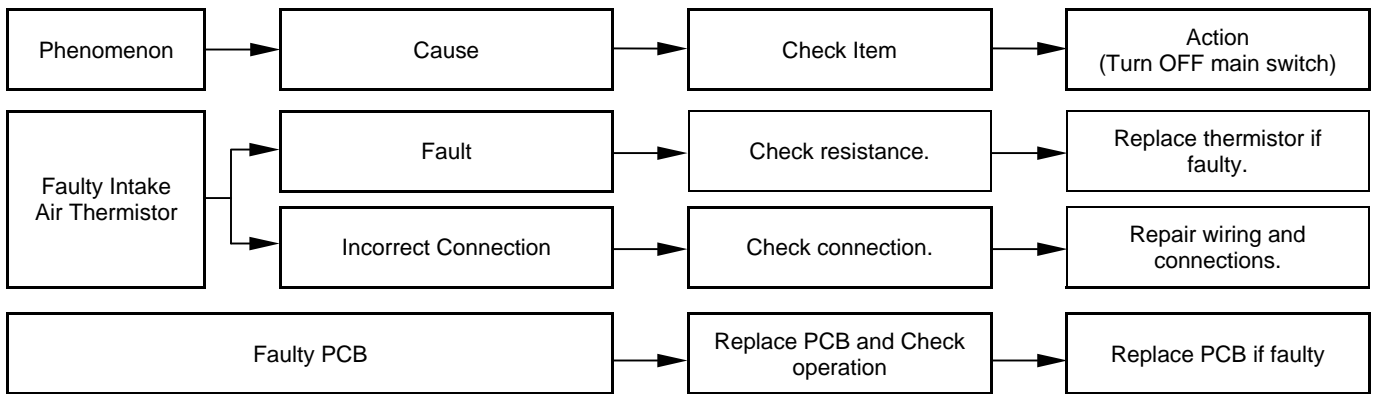
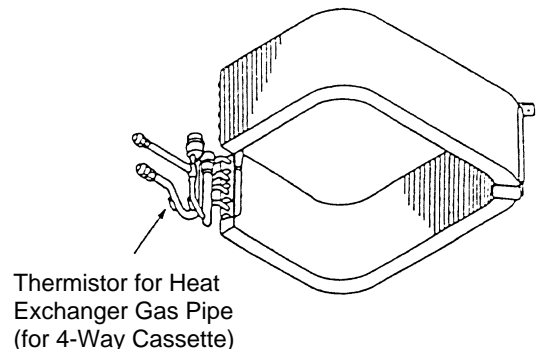
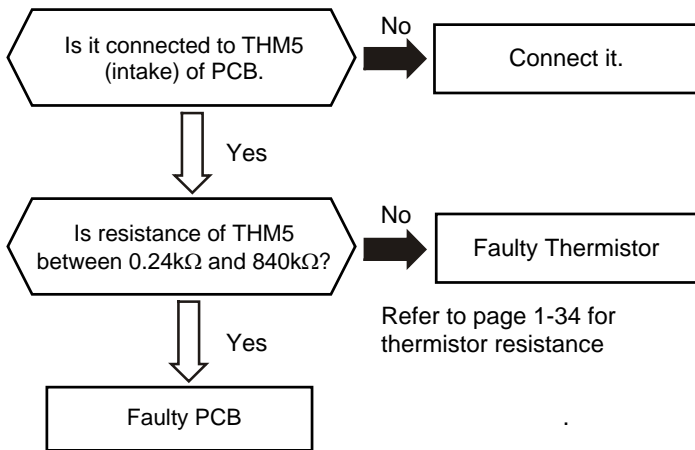

Alarm Code	Activation of Protection Device for Indoor Fan Motor (except RPK-Model)
19	

- "RUN" light flickers and "ALARM" is indicated on the remote control switch.
- The unit No., alarm code and the unit code is alternately indicated on the set temperature section, and the unit No. and alarm code are indicated on the display of the outdoor unit PCB.
- ★ This alarm code is indicated when the temperature of the internal thermostat for the indoor fan motor is higher than 130 °C.

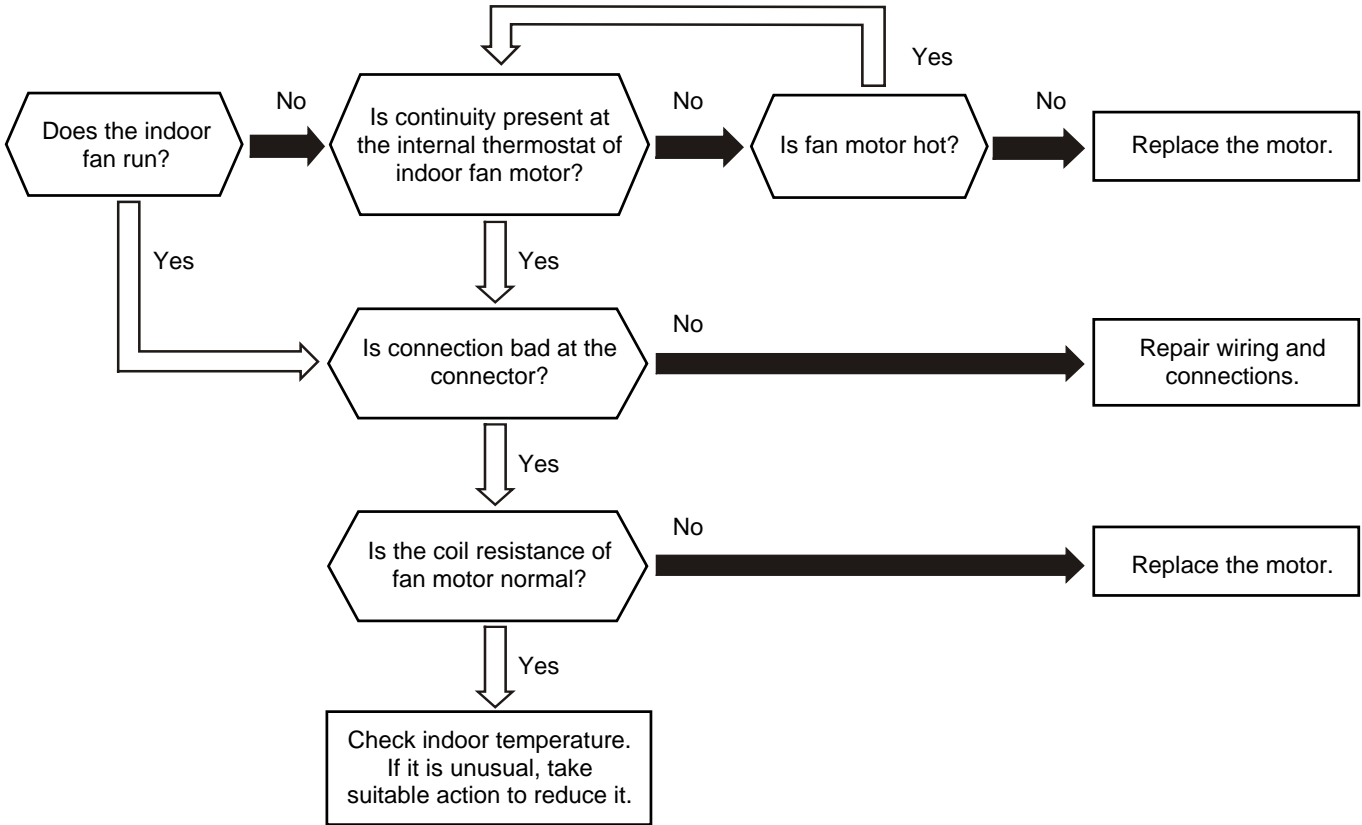

Phenomenon	Cause	Check Item	Action (Turn OFF main switch)	
Activation of Internal Thermostat for Indoor Unit Fan Motor	Faulty Indoor Unit Fan Motor	Measure coil resistance and insulation resistance.	Replace motor if faulty.	
	Faulty Internal Thermostat	Fault	Check continuity after Fan motor temperature decreases to room temp.	Replace fan motor if no continuity
		Insufficient Contacting	Measure resistance by tester.	Correct Looseness. replace connectors.
		Incorrect Connection	Check connections.	Repair connections.

Alarm Code	Activation of Protection Device for Indoor Fan Motor (RPK-Model)
19	

- "RUN" light flickers and "ALARM" is indicated on the remote control switch.
- The unit No., alarm code and the unit code is alternately indicated on the set temperature section, and the unit No. and alarm code are indicated on the display of the outdoor unit PCB.
- ★ This alarm code is indicated when the running current of the indoor fan motor is higher than 1A.

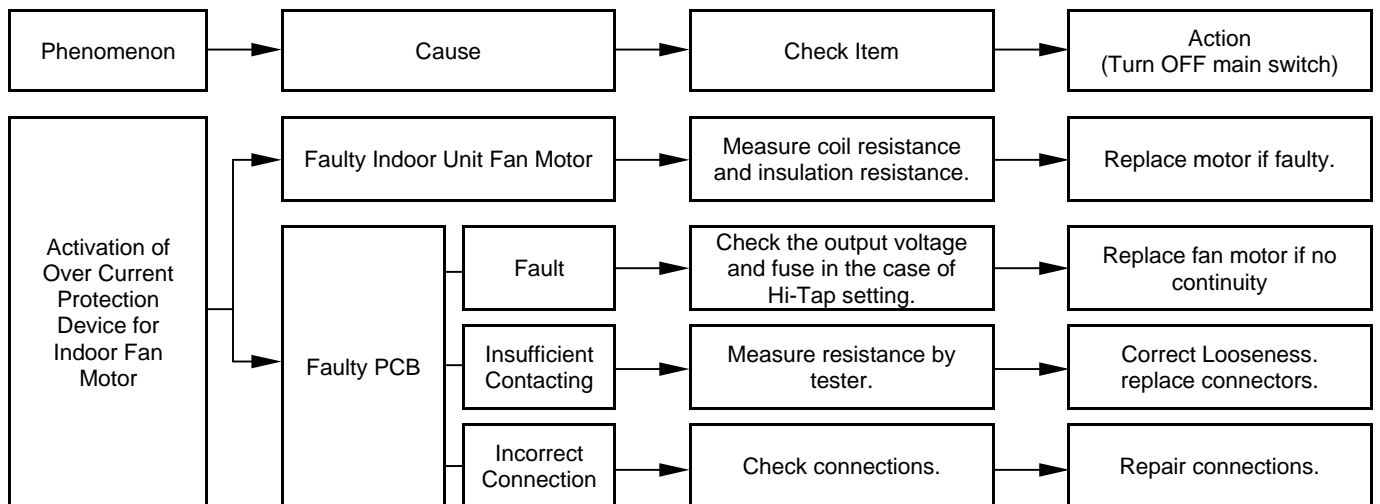
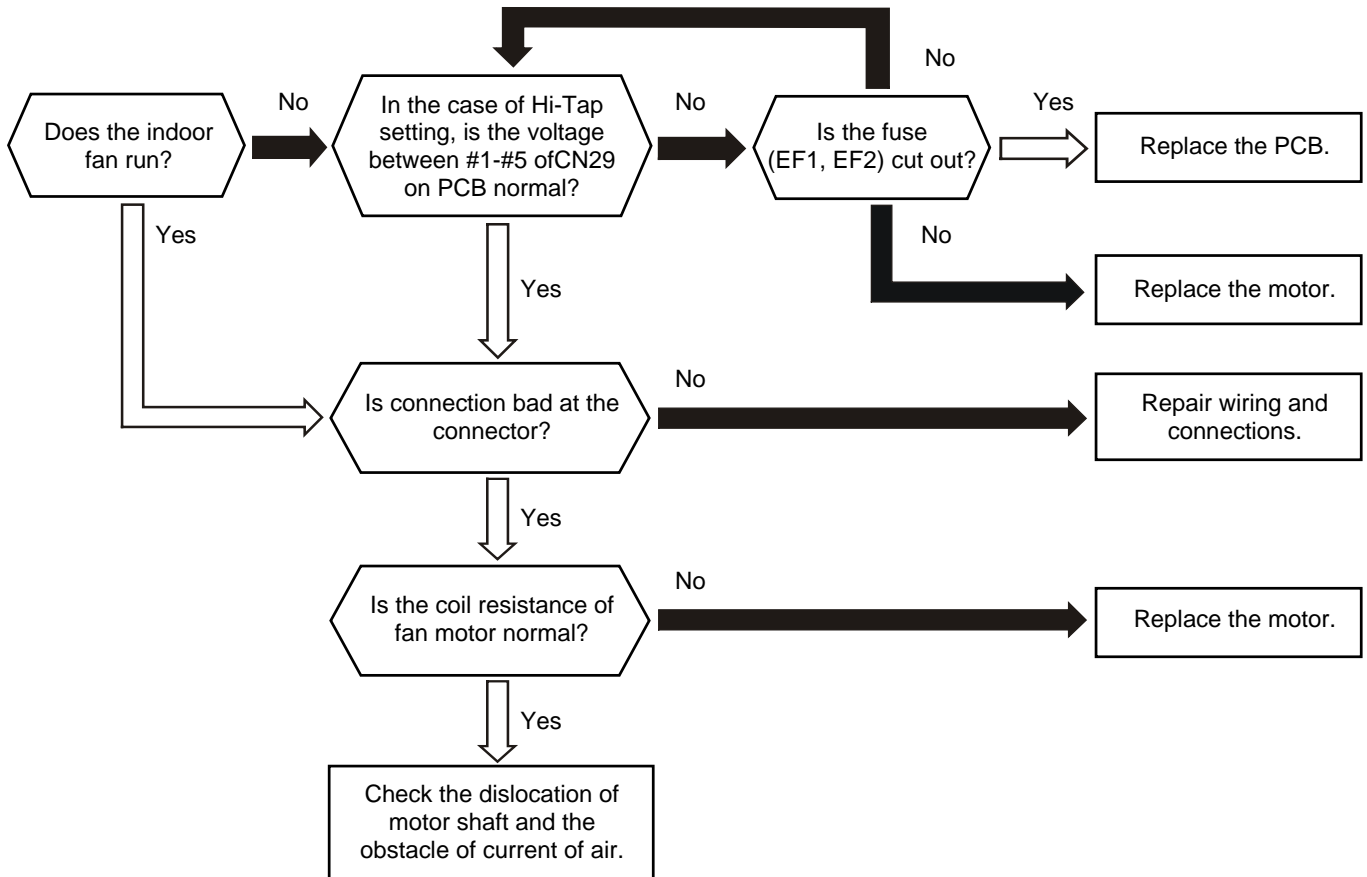

Alarm Code	Abnormality of High Pressure Sensor for Outdoor Unit
21	

- "RUN" light flickers and "ALARM" is indicated on the remote control switch.
- The unit No., alarm code and the unit code is alternately indicated on the set temperature section, and the unit No. and alarm code are indicated on the display of the outdoor unit PCB.
- ★ This alarm code is indicated when the pressure sensor voltage decreases lower than 0.1 V or increases higher than 4.9V during running.

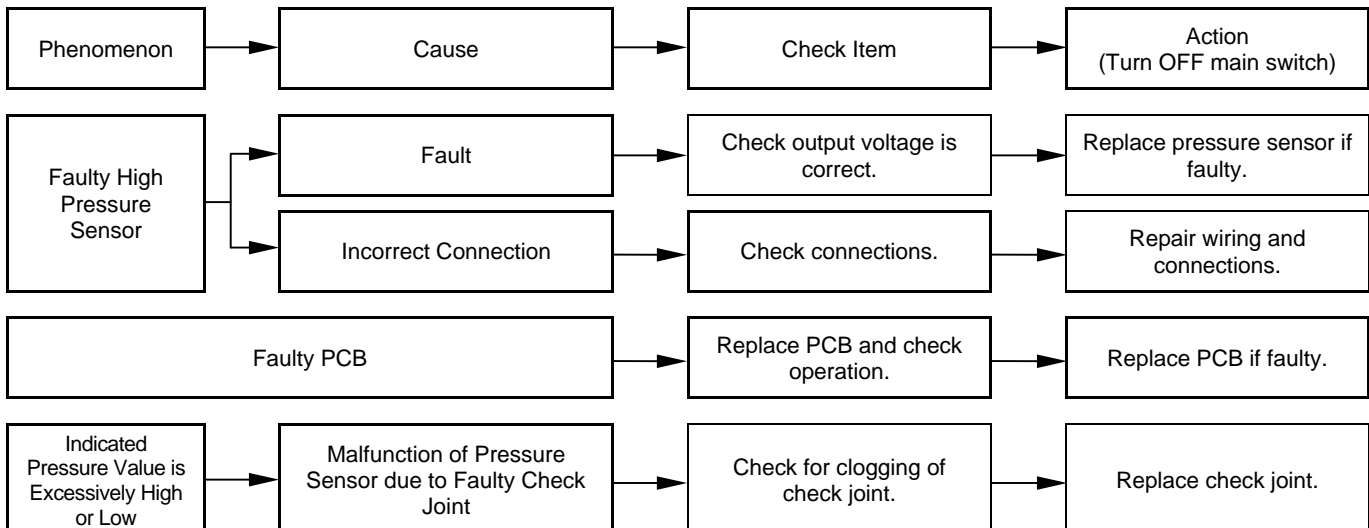
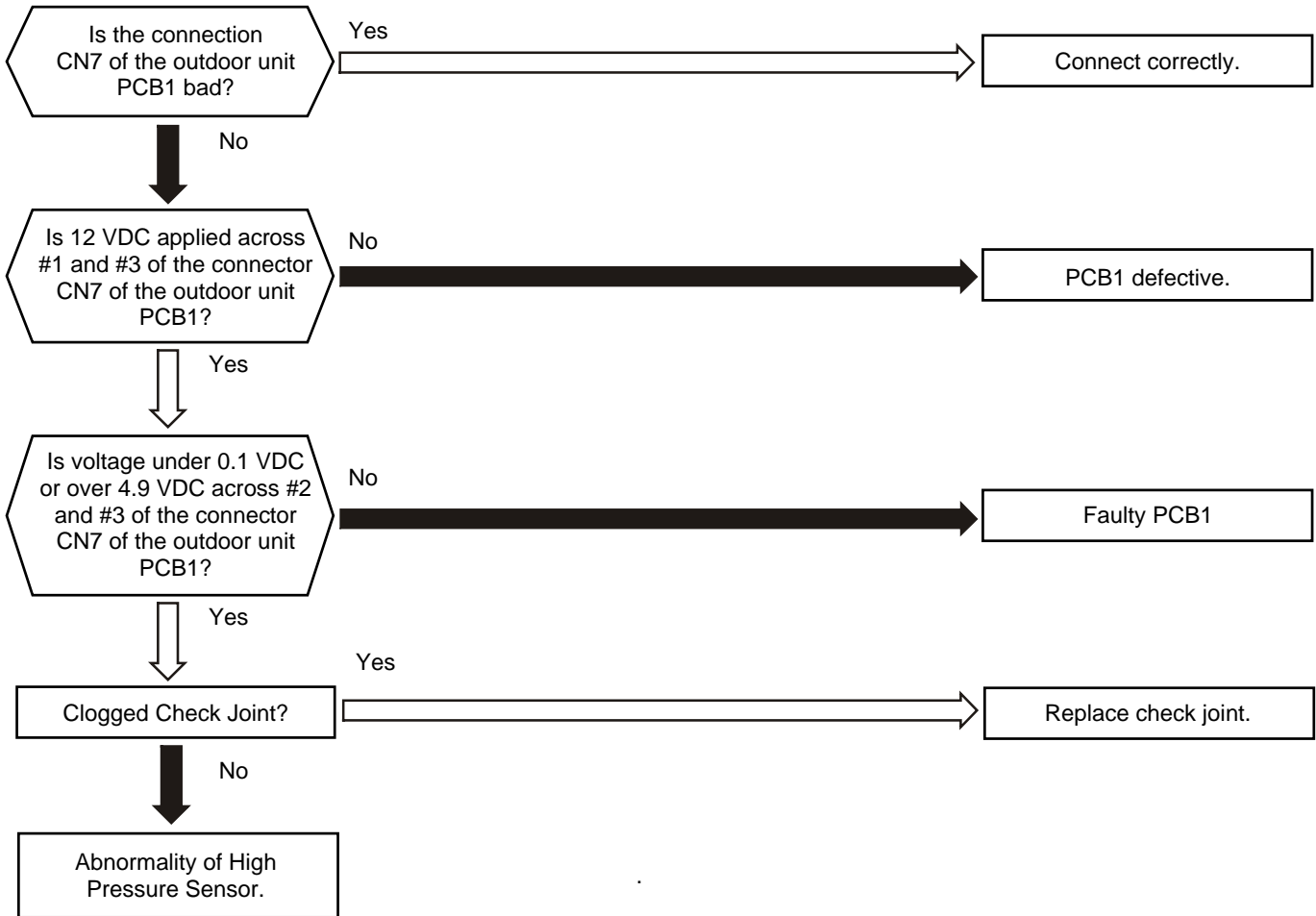

Alarm Code	Abnormality of Thermistor for Outdoor Air Temperature (Outdoor Unit Ambient Thermistor)
22	

- "RUN" light flickers and "ALARM" is indicated on the remote control switch.
- The unit No., alarm code and the unit code is alternately indicated on the set temperature section, and the unit No. and alarm code are indicated on the display of the outdoor unit PCB.
- ★ This alarm code is indicated when the thermistor is short-circuited (less than 0.2 kΩ) or cut (greater than 500 kΩ) during running. However, this alarm occurs during test running mode only. In the case that the thermistor is abnormal during running, operation continues based on the assumption that the outdoor temperature, is 35 °C (Cooling) / 6 °C (Heating).

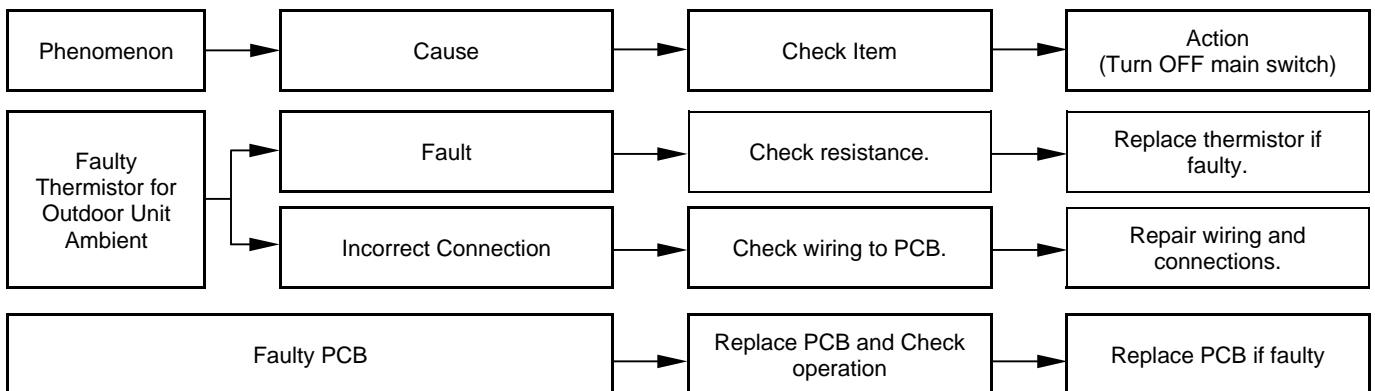
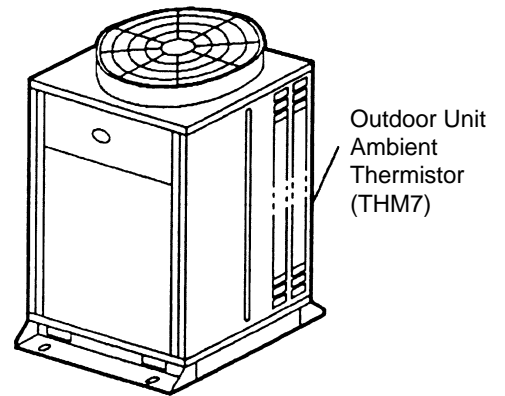
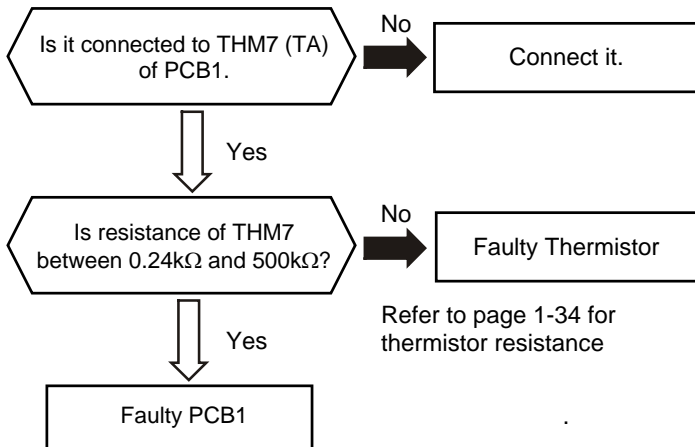

Alarm Code	Abnormality of Thermistor for Discharge Gas Temperature on the Top of Compressor Chamber
23	

- "RUN" light flickers and "ALARM" is indicated on the remote control switch.
- The unit No., alarm code and the unit code is alternately indicated on the set temperature section, or the unit No. and alarm code are indicated on the display of the outdoor unit PCB. (*1)
If abnormality with the thermistor is found, check all the thermistors as shown below.
- ★ This alarm code is indicated when the thermistor is short-circuited (less than 0.9 kΩ) or cut (greater than 2,350 kΩ) during running.

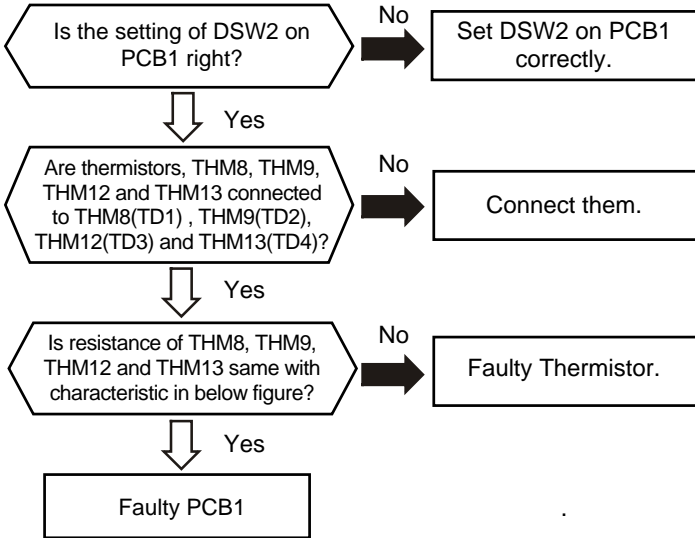

Position of the Thermistor

		Model RAS-[HP]FSG/FS3					Thermistor position (a)
Thermistor ref.	Display	5	8	10	16	20	
THM8	<i>Fd1</i>	Inverter					
THM9	<i>Fd2</i>	fix compressor					
THM12	<i>Fd3</i>						
THM13	<i>Fd4</i>						
No. of compressors		1	2	2	3	4	

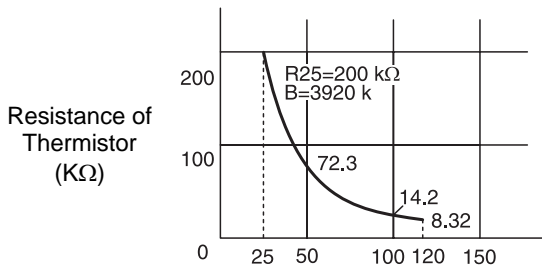

Characteristics Of Thermistor

- 1 2 3 Faulty TD1
- 2 2 3 Faulty TD2
- 3 2 3 Faulty TD3
- 4 2 3 Faulty TD4

(*1) Indication on the display of the outdoor unit PCB

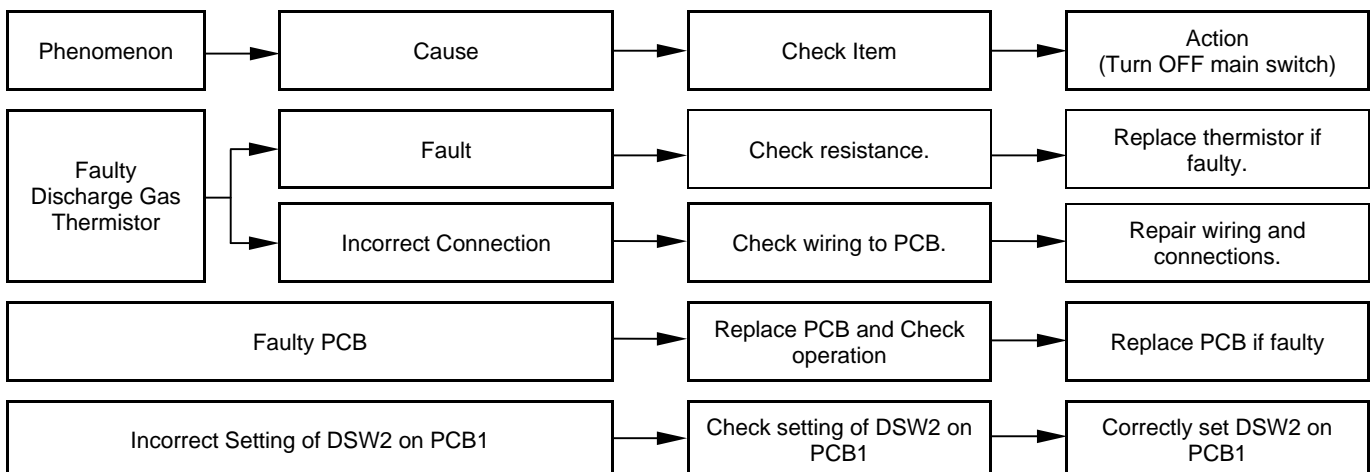

Alarm Code	Abnormality of Thermistor for Evaporating Temperature during Heating Operation (Outdoor Unit)
24	

- "RUN" light flickers and "ALARM" is indicated on the remote control switch.
- The unit No., alarm code and the unit code is alternately indicated on the set temperature section, and or the unit No. and alarm code are indicated on the display of the outdoor unit PCB. (*1)
If abnormality with the thermistor is found, check all the thermistors as shown below.
- ★ The evaporating thermistor during the heating operation is attached to the heat exchanger as shown below figure.
If this thermistor is faulty, this alarm is indicated. The position is indicated below.

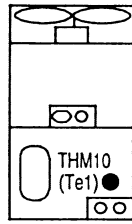

RAS-5FSG/FS3
RAS-8FSG/FS3
RAS-10FSG/FS3

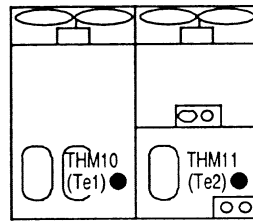

RAS-16FSG/FS3
RAS-20FSG/FS3

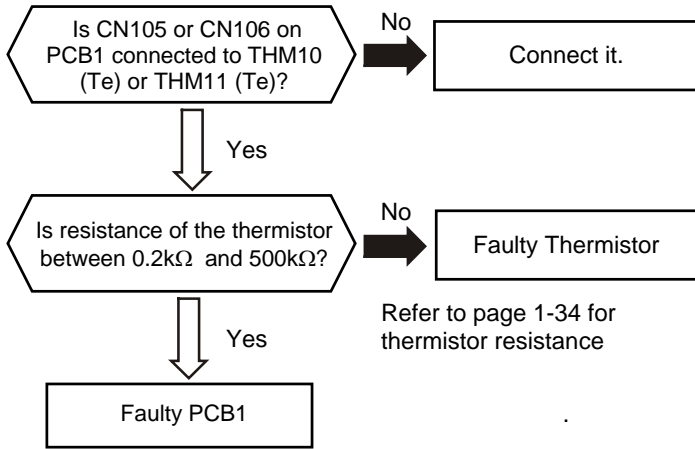

(*1) Indication on the display of the outdoor unit PCB

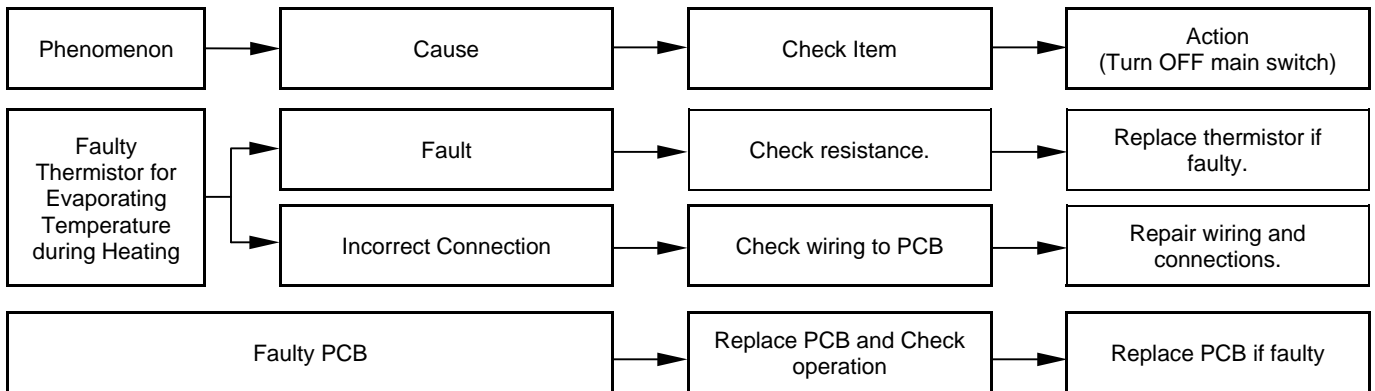

Alarm Code	Abnormality of Low Pressure Sensor for Outdoor Unit
29	

- "RUN" light flickers and "ALARM" is indicated on the remote control switch.
- The unit No., alarm code and the unit code is alternately indicated on the set temperature section, and the unit No. and alarm code are indicated on the display of the outdoor unit PCB.
- ★ This alarm code is indicated when the pressure sensor voltage decreases lower than 0.1 V or increases higher than 4.9V during running.

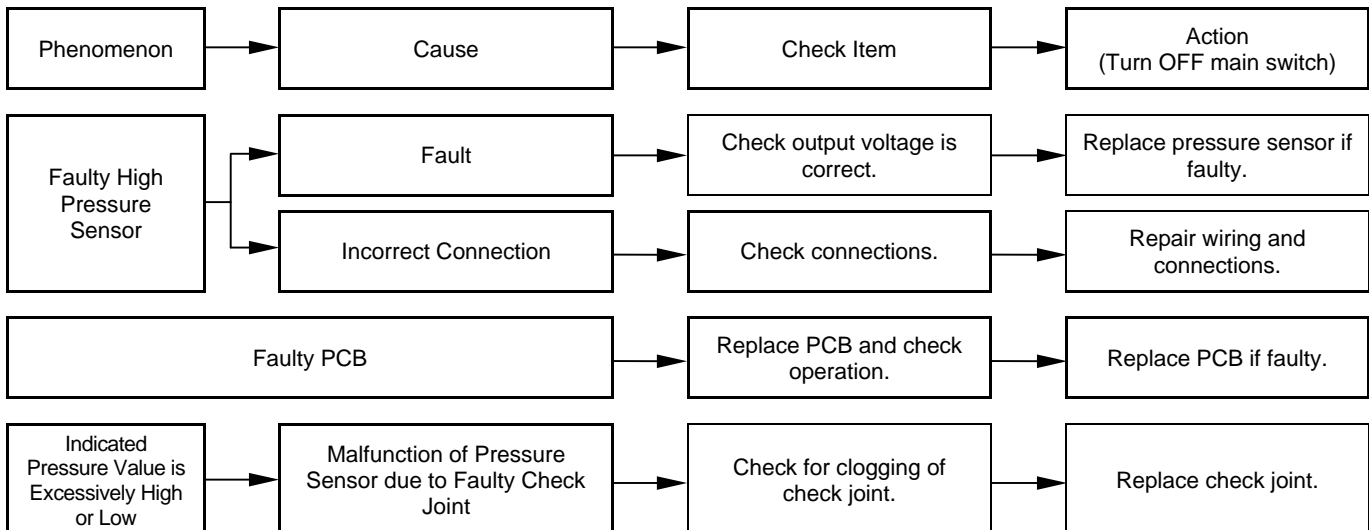
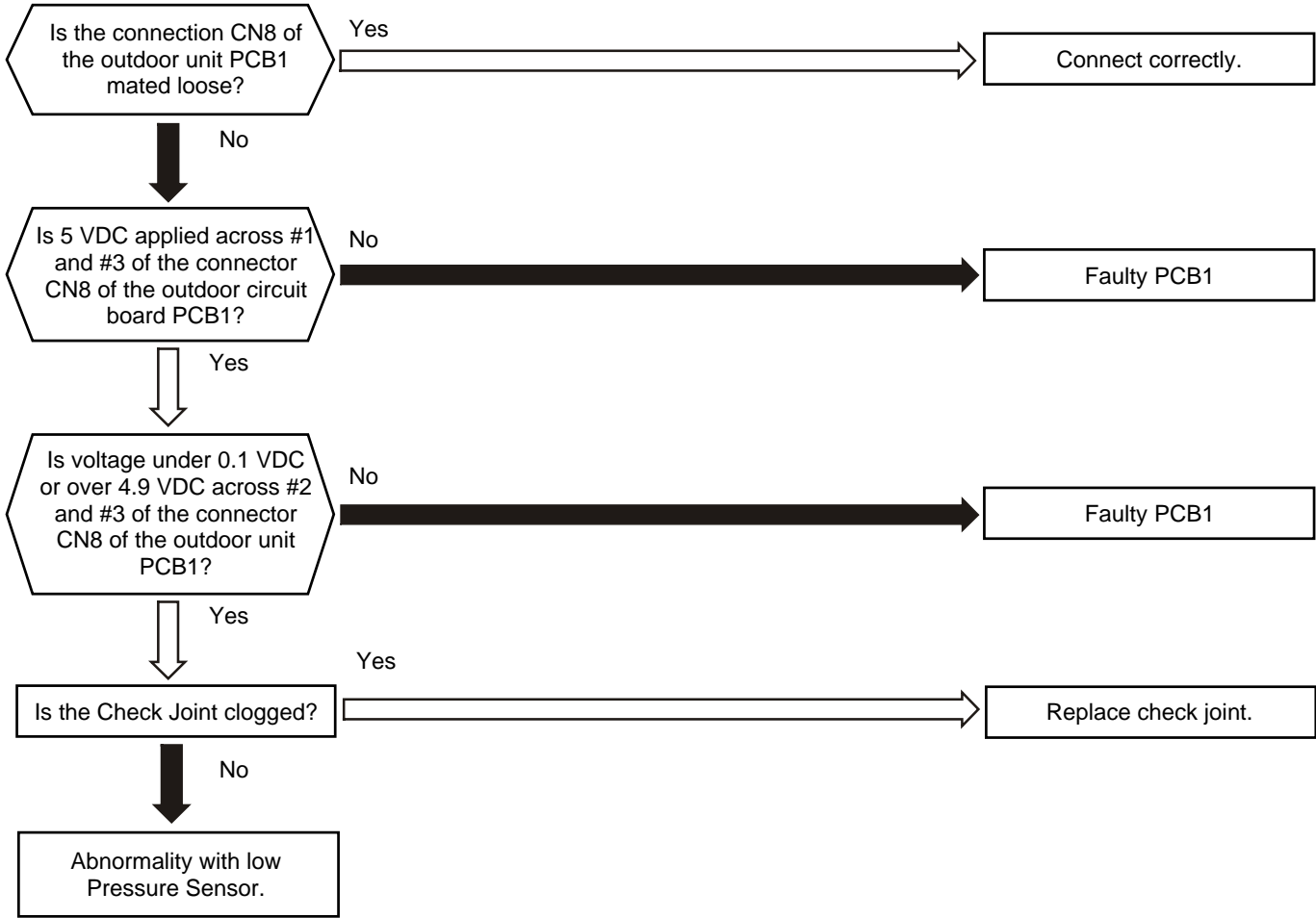

Alarm Code	Incorrect Capacity Setting or Combined Capacity between Indoor Units and Outdoor Unit
31	

- "RUN" light flickers and "ALARM" is indicated on the remote control switch.
- The unit No., alarm code and the unit code is alternately indicated on the set temperature section, and the unit No. and alarm code are indicated on the display of the outdoor unit PCB.
- ★ This alarm code is indicated when the capacity setting dip switch, DSW2 on the outdoor unit PCB1, is not set (all the settings from #1 to #3 are OFF) or mis setting.
- ★ This alarm code is indicated when the total indoor unit capacity is smaller than 50% or greater than 150% of the combined outdoor unit capacity.

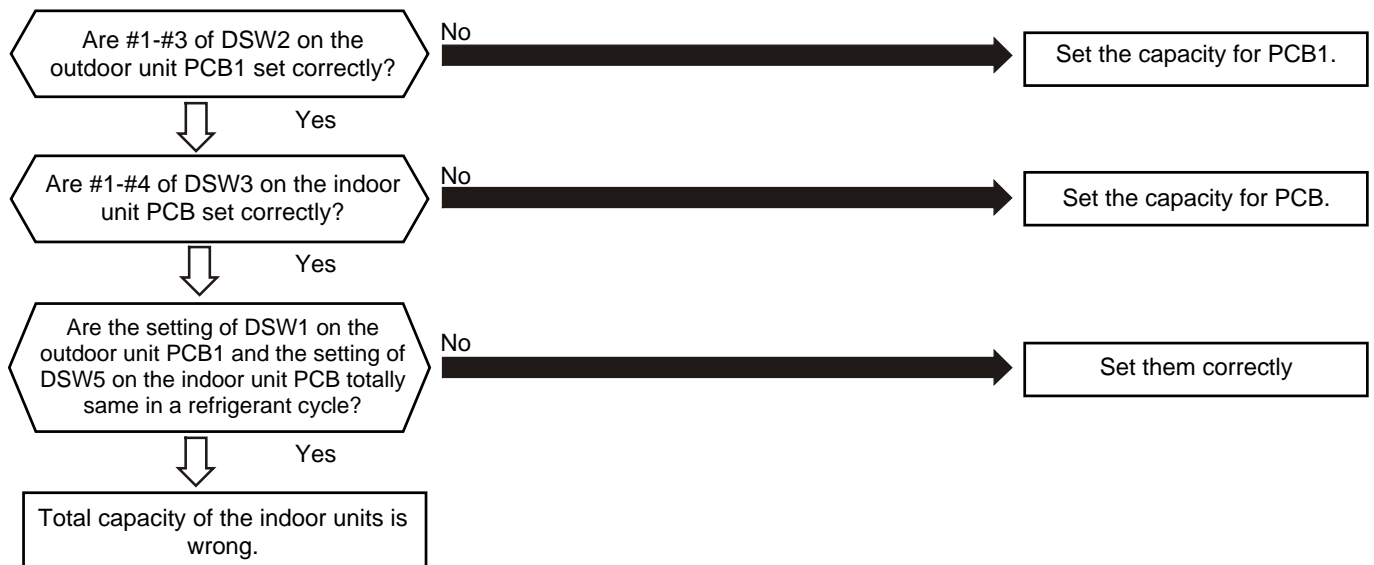

Phenomenon	Cause	Check Item	Action (Turn OFF main switch)
Incorrect Capacity Setting of Indoor Unit		Check combination of indoor units and capacity setting on PCB.	Correctly set dip switch, DSW3.
Incorrect Capacity Setting of Outdoor Unit		Check capacity setting on outdoor unit PCB.	Correctly set dip switch, DSW2.
Total Indoor Unit Capacity Connected to the Outdoor Unit is Beyond Permissible Range		Check outdoor unit model by calculating total indoor units capacity.	Ensure that total indoor unit capacity is from 50% to 130%.
Refrigeration Cycle Setting of Outdoor Unit and Indoor Unit is Different.		Check refrigeration cycle setting on outdoor unit PCB and indoor unit PCB.	Set them correctly.

Combination

Outdoor Unit Model	Combined Indoor Unit		Notes
	Total Quantity	Total Capacity (HP)	
RAS-5FSG, RAS-5FS3	2-8 sets *1)	2.5-6.5	*1): If the capacity of one indoor unit is the same as of the outdoor unit, the system can be operated.
RAS-8FSG, RAS-8FS3	2-12 sets	4.0-10.4	
RAS-10FSG, RAS-10FS3		5.0-13.0	
RAS-16FSG, RAS-16FS3	2-13(16) sets *2)	8.0-20.8	*2): In case of changing the indoor unit capacity from 1.0HP or 1.5HP to 1.3HP by dip switch setting.
RAS-20FSG, RAS-20FS3	2-16 sets	10.0-26.0	

Alarm Code	Abnormality in Transmitting of Other Indoor Units
32	

- "RUN" light flickers and "ALARM" is indicated on the remote control switch.
- The unit No., alarm code and the unit code is alternately indicated on the set temperature section, and the unit No. and alarm code are indicated on the display of the outdoor unit PCB.
- ★ This alarm code is indicated on the remote control switch of other indoor unit when no transmitting data is issued from a malfunctioning indoor unit for more than 60 minutes after receiving transmitting data from the indoor unit.

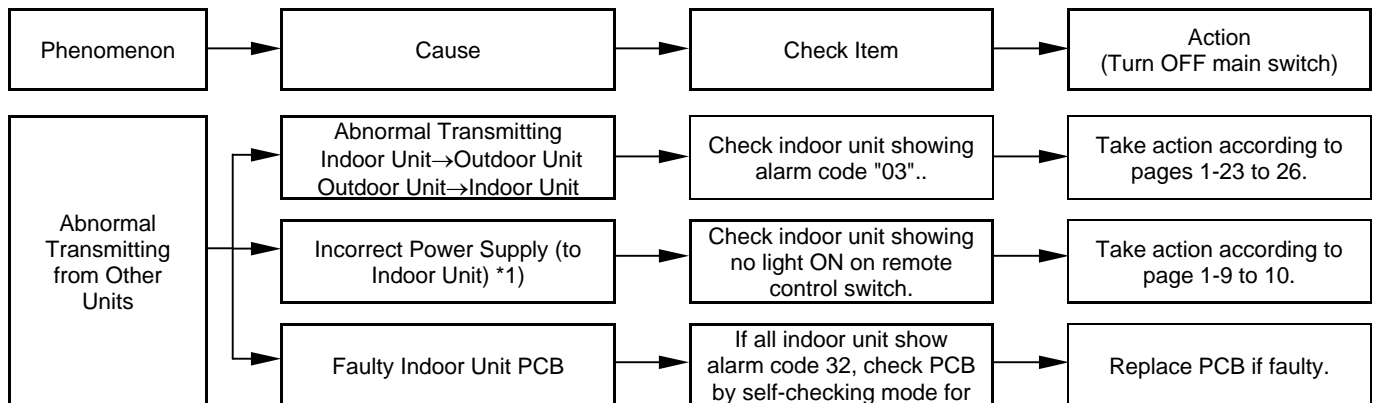
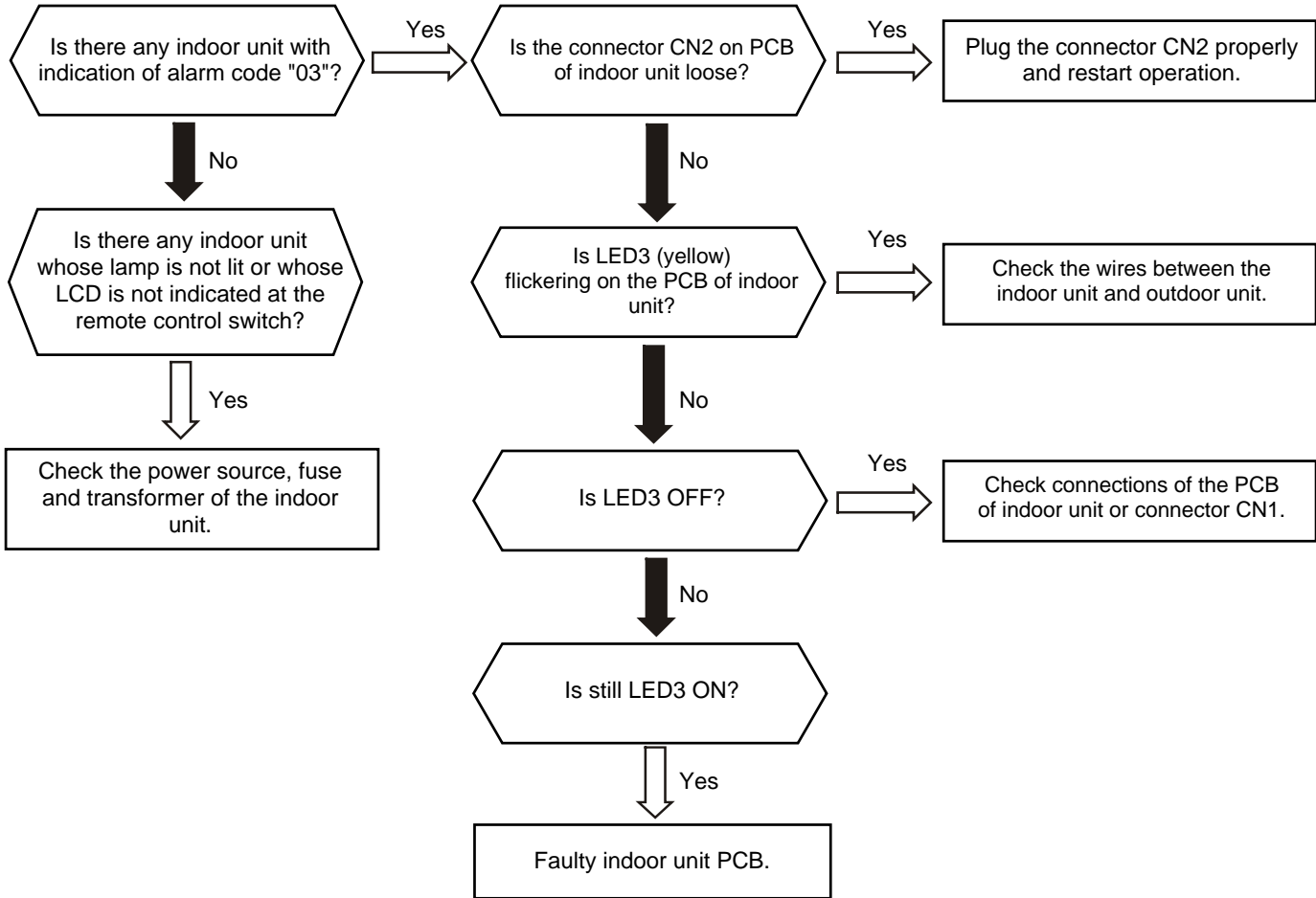

*1): This abnormality is indicated on an indoor unit which is normal, since this is due to abnormality of transmitting of the indoor units or power source abnormality in the same refrigeration cycle and electrical system. If the power source is abnormal, abnormality can not be indicated by its indoor unit, so, this alarm is indicated on the remote control switch of other normal indoor unit.

Alarm Code	Incorrect Indoor Unit No. Setting
35	

- "RUN" light flickers and "ALARM" is indicated on the remote control switch.
- The unit No., alarm code and the unit code is alternately indicated on the set temperature section, and the unit No. and alarm code are indicated on the display of the outdoor unit PCB.
- ★ This alarm code is indicated 3 minutes after power is supplied to the outdoor unit when the indoor unit No. connected to the outdoor unit is duplicated by setting of RSW.

In the case of H-Link System, this alarm code is indicated when DSW1 of the outdoor unit PCB and DSW5 of the indoor unit PCB are incorrectly set.
In this case, set correctly DSW1 and DSW5 after turning off Main Switch.

Alarm Code	Abnormality of Picking up Circuit for Protection (Outdoor Unit)
38	

- "RUN" light flickers and "ALARM" is indicated on the remote control switch.
- The unit No., alarm code and the unit code is alternately indicated on the set temperature section, and the unit No. and alarm code are indicated on the display of the outdoor unit PCB.
- ★ This alarm code is indicated when AC 220V or 240V is supplied to voltage between terminal #3 of PCN14 on PCB1 and faston terminal N on PCB1 in the outdoor unit during inverter compressor stoppage.

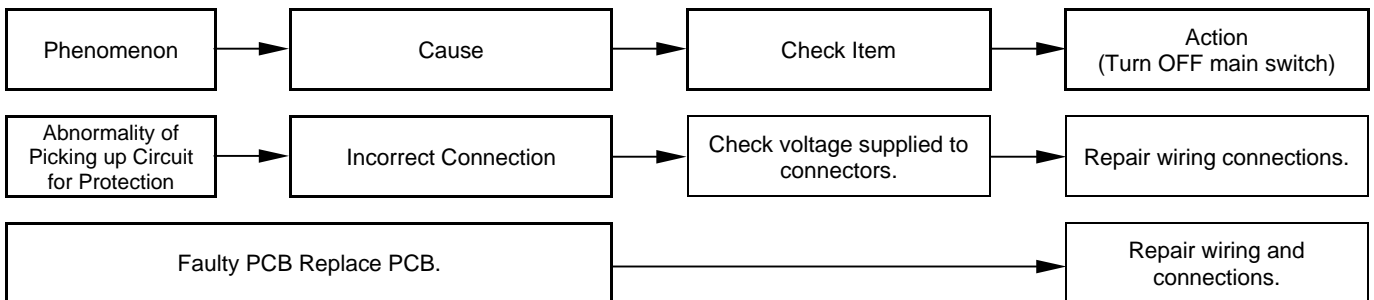
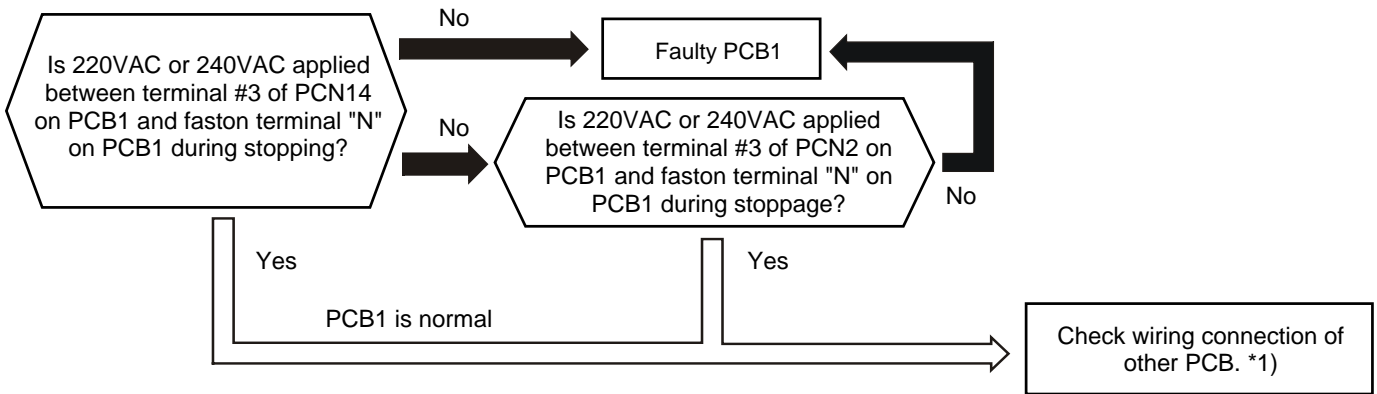

*1): Check wiring system connecting to PCN14 and PCN2 on PCB1.

Alarm Code	Abnormality of Running Current at Constant Compressor
39	

- "RUN" light flickers and "ALARM" is indicated on the remote control switch.
- The unit No., alarm code and the unit code is alternately indicated on the set temperature section, and the unit No. and alarm code are indicated on the display of the outdoor unit PCB.
- ★ This alarm code is indicated when the following conditions occurs;
 The running current of the constant compressor exceeds the value of overcurrent limitation during operating.
 The running current of the constant compressor is detected 0A and retry when 3 minutes are passed after all compressors are stopped, and this phenomenon occurs three times within 30 minutes.

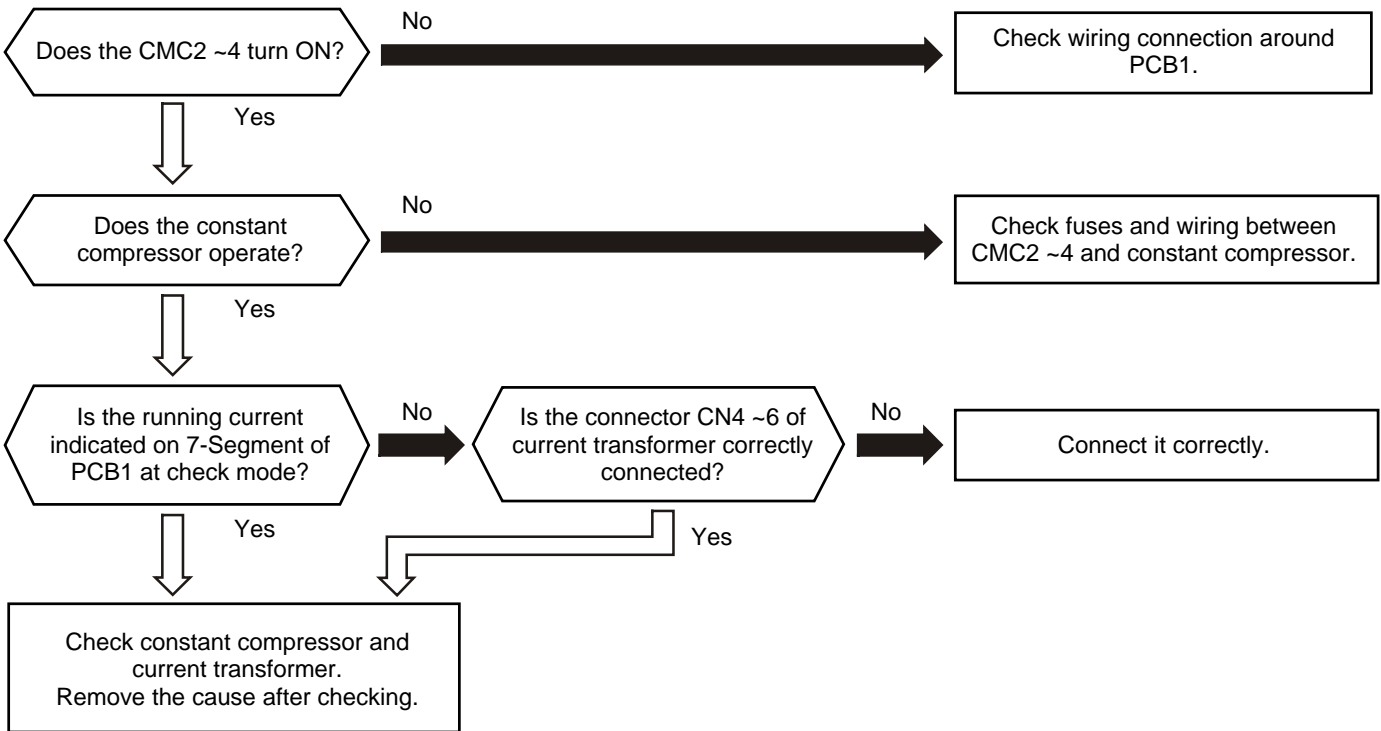

Indication of 7-Segment Abnormality of Constant Compressor

2	3	9	MC2
3	3	9	MC3
4	3	9	MC4

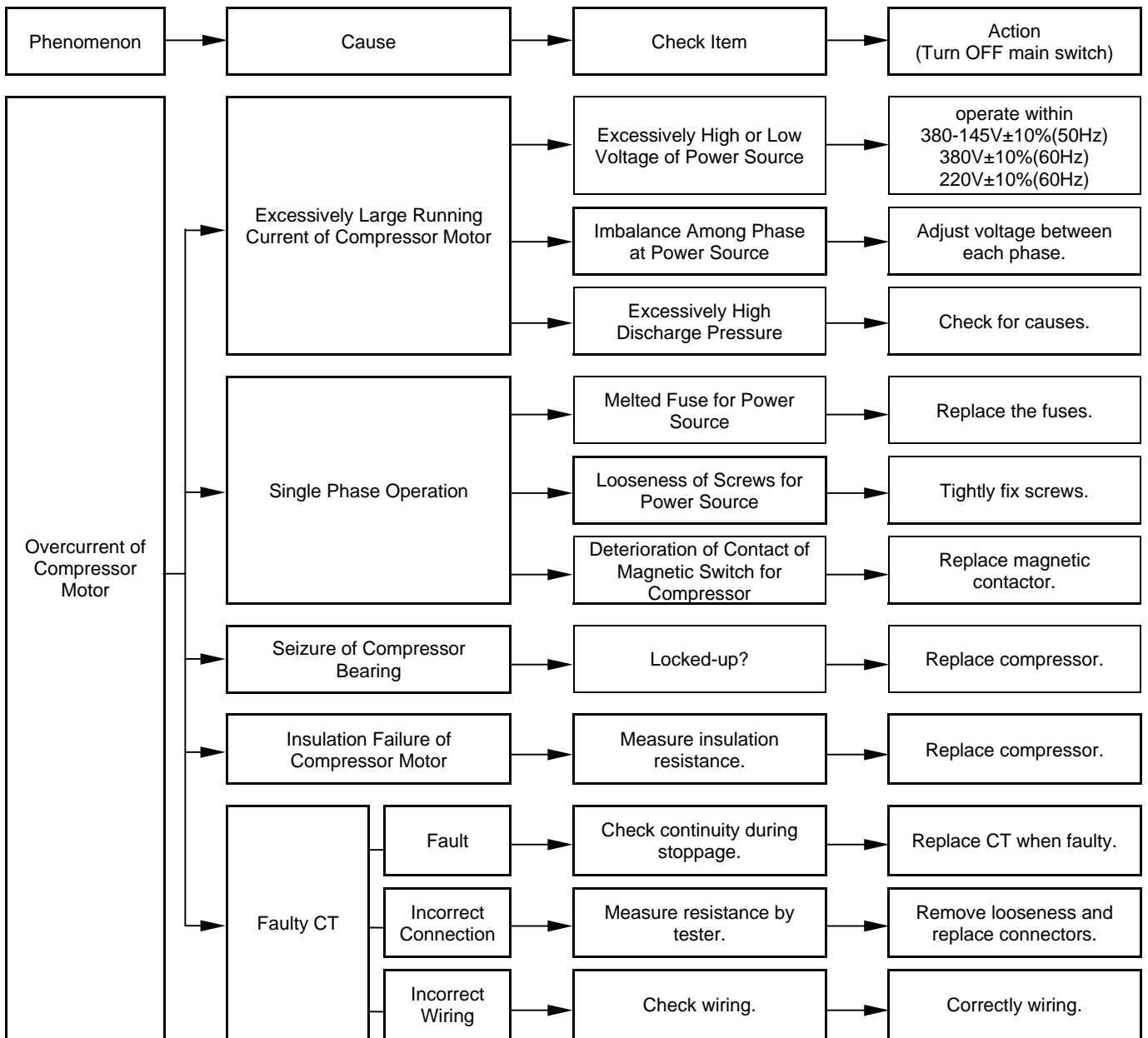

Alarm Code	43	Activation to Protect System from Low Compression Ratio
------------	-----------	----------------------------------------------------------------

- "RUN" light flickers and "ALARM" is indicated on the remote control switch.
- The unit No., alarm code and the unit code is alternately indicated on the set temperature section, and the unit No. and alarm code are indicated on the display of the outdoor unit PCB.
- ★ This alarm code is indicated when a compression ratio , $\epsilon = \{(Pd + 0.1) / (Ps + 0.1)\}$ is calculated from a discharge pressure (MPa) and suction pressure (MPa) and the condition lower than $\epsilon = 1.8$ occurs more than 3 times including 3 in one hour.

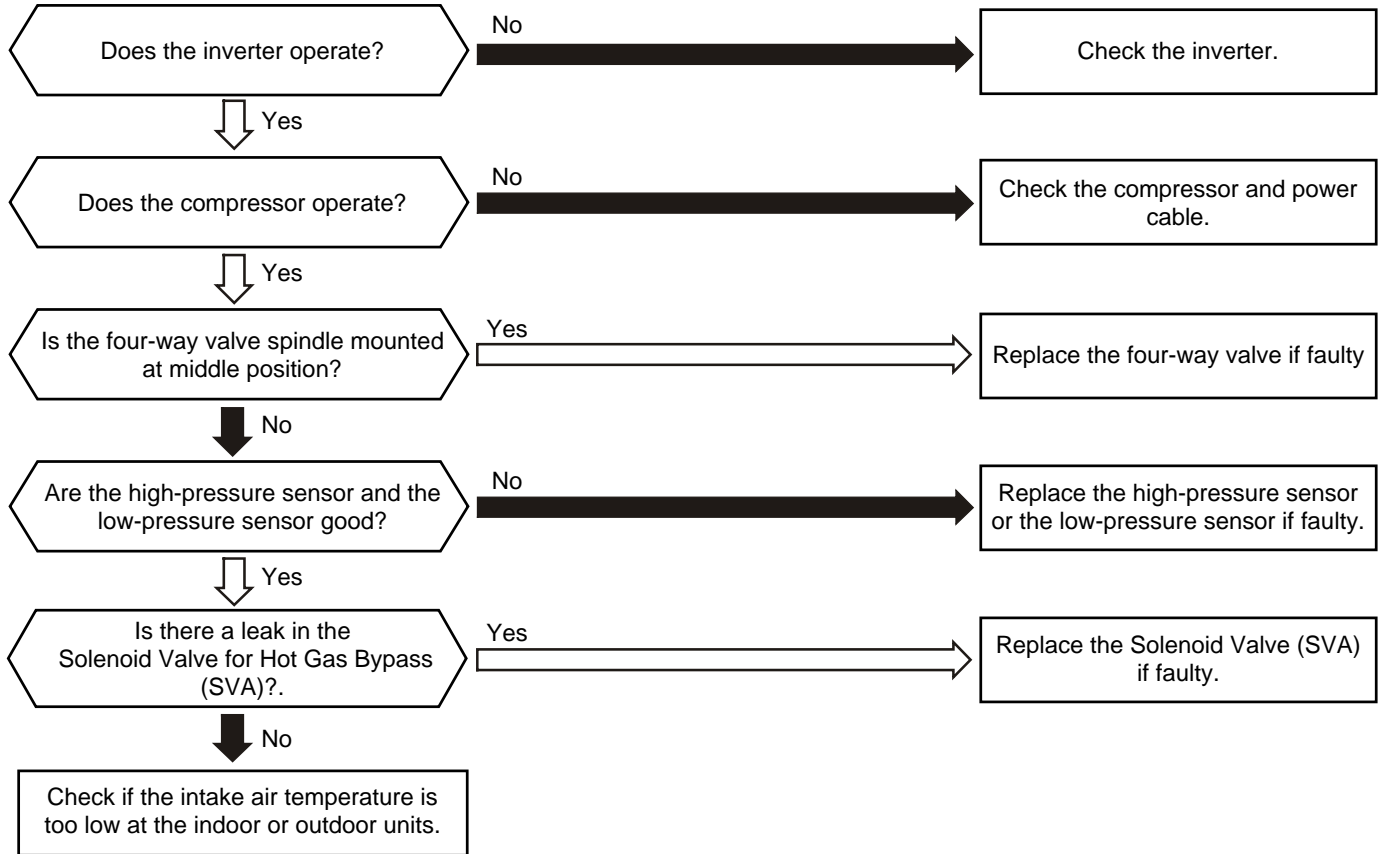

Phenomenon	Cause	Check Item	Action (Turn OFF main switch)
Excessively Low Compression Ratio	Inverter is not Functioning	Check inverter.	Repair faulty part.
	Compressor is not Operating	Check compressor.	Replace comp. if faulty.
	Valve Stoppage at Medium Position of 4-Way Valve	Measure suction pipe temp. of 4-way valve.	Replace 4-way valve if faulty.
	Abnormality of High or Low Pressure Sensor	Check connector for PCB, power source and pressure indication.	Replace sensor if faulty.
	Excessively Low Indoor Intake Air Temperature	Check indoor unit and outdoor unit air temp. thermistor.	Replace thermistor if faulty.
	Leakage from Solenoid Valve: SVA Outdoor Unit	Check Solenoid Valve.	Replace SVA if leaking.

Alarm Code	Activation to Protect System from Excessively High Suction Pressure
44	

- "RUN" light flickers and "ALARM" is indicated on the remote control switch.
- The unit No., alarm code and the unit code is alternately indicated on the set temperature section, and the unit No. and alarm code are indicated on the display of the outdoor unit PCB.
- ★ This alarm code is indicated when the compressor is operated under the conditions higher than 0.9 MPa of suction pressure and its occurrence is more than 3 times including 3 in one hour.

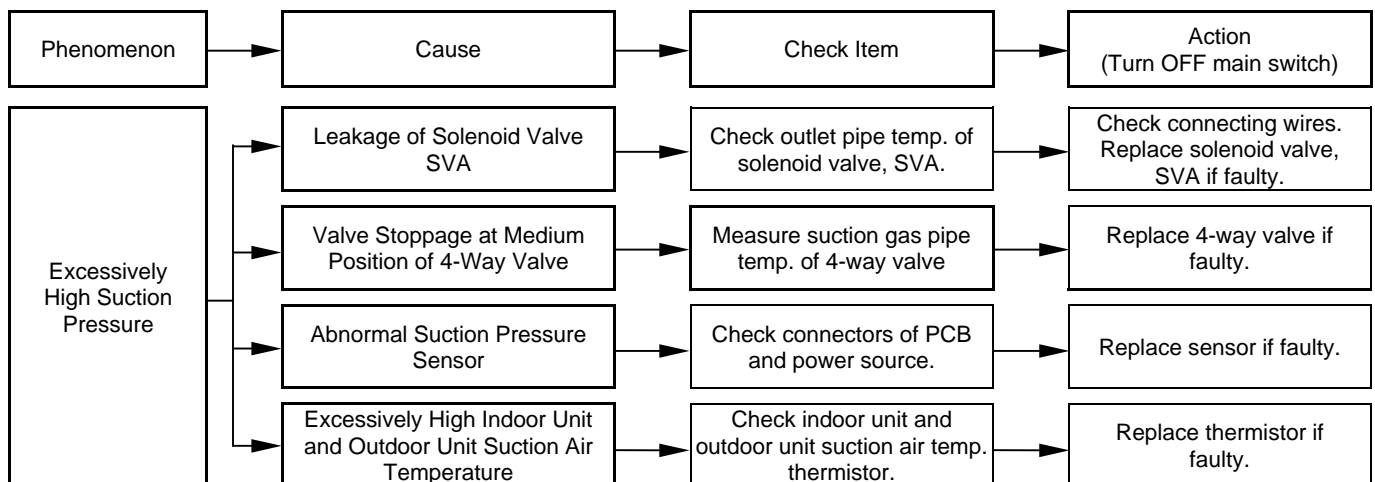
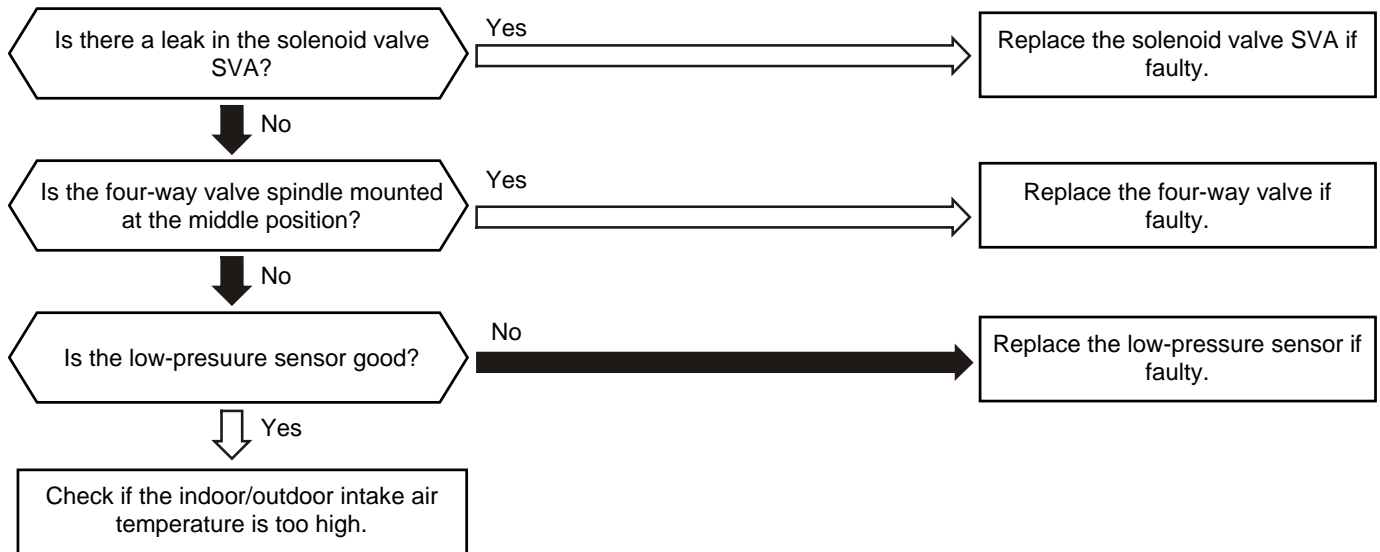

Alarm Code	45	Activation to Protect System from Excessively High Discharge Pressure
------------	-----------	------------------------------------------------------------------------------

- "RUN" light flickers and "ALARM" is indicated on the remote control switch.
- The unit No., alarm code and the unit code is alternately indicated on the set temperature section, and the unit No. and alarm code are indicated on the display of the outdoor unit PCB.
- ★ This alarm code is indicated when the compressor is operated under the conditions higher than 2.7 MPa (27 kg/cm²G) of discharge pressure (in case of frequency 30Hz, Pd is higher than 2.5 MPa (25 kg/cm²G) and its occurrence is more than 3 times including 3 in one hour).

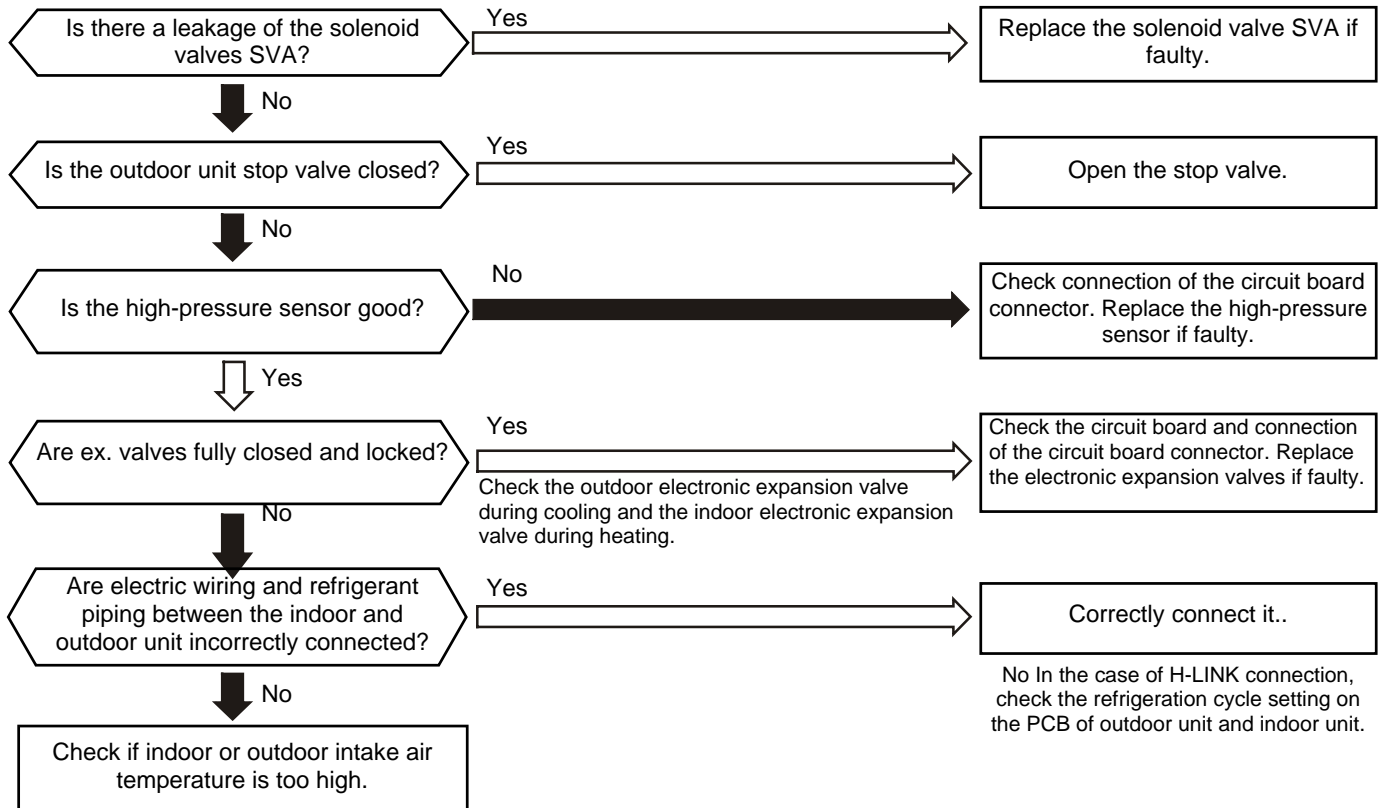

Phenomenon	Cause	Check Item	Action (Turn OFF main switch)
Excessively High Discharge Pressure	Leakage of Solenoid Valve SVA (Outdoor Unit)	Check outlet temp. of solenoid valve, SVA.	Check connection. Replace solenoid valve SVA if faulty.
	Closed Stop Valve	Check stop valve.	Open stop valve.
	Abnormal High Pressure Sensor	Check connectors for PCB.	Replace pressure sensor if faulty.
	Excessively High Indoor Unit and Outdoor Unit Inlet Air Temp.	Check thermistor for indoor unit and outdoor unit inlet air temp.	Replace thermistor if faulty.
	Incorrect Connection between Indoor Unit and Outdoor Unit	.Check electrical system and ref. cycle.	Correctly Connect.
	Locked Ex. Valve with Fully Closed Opening	Check connector for PCB.	Repair connector for PCB or ex. valve. Replace it if faulty.

Alarm Code	Activation to Protect System from Excessively Low Discharge Pressure (for Protection of Refrigerant Shortage)
45	

- "RUN" light flickers and "ALARM" is indicated on the remote control switch.
- The unit No., alarm code and the unit code is alternately indicated on the set temperature section, and the unit No. and alarm code are indicated on the display of the outdoor unit PCB.
- ★ This alarm code is indicated when the compressor is operated under the conditions higher than 0.6MPa (6kgf/cm²G) for an hour.

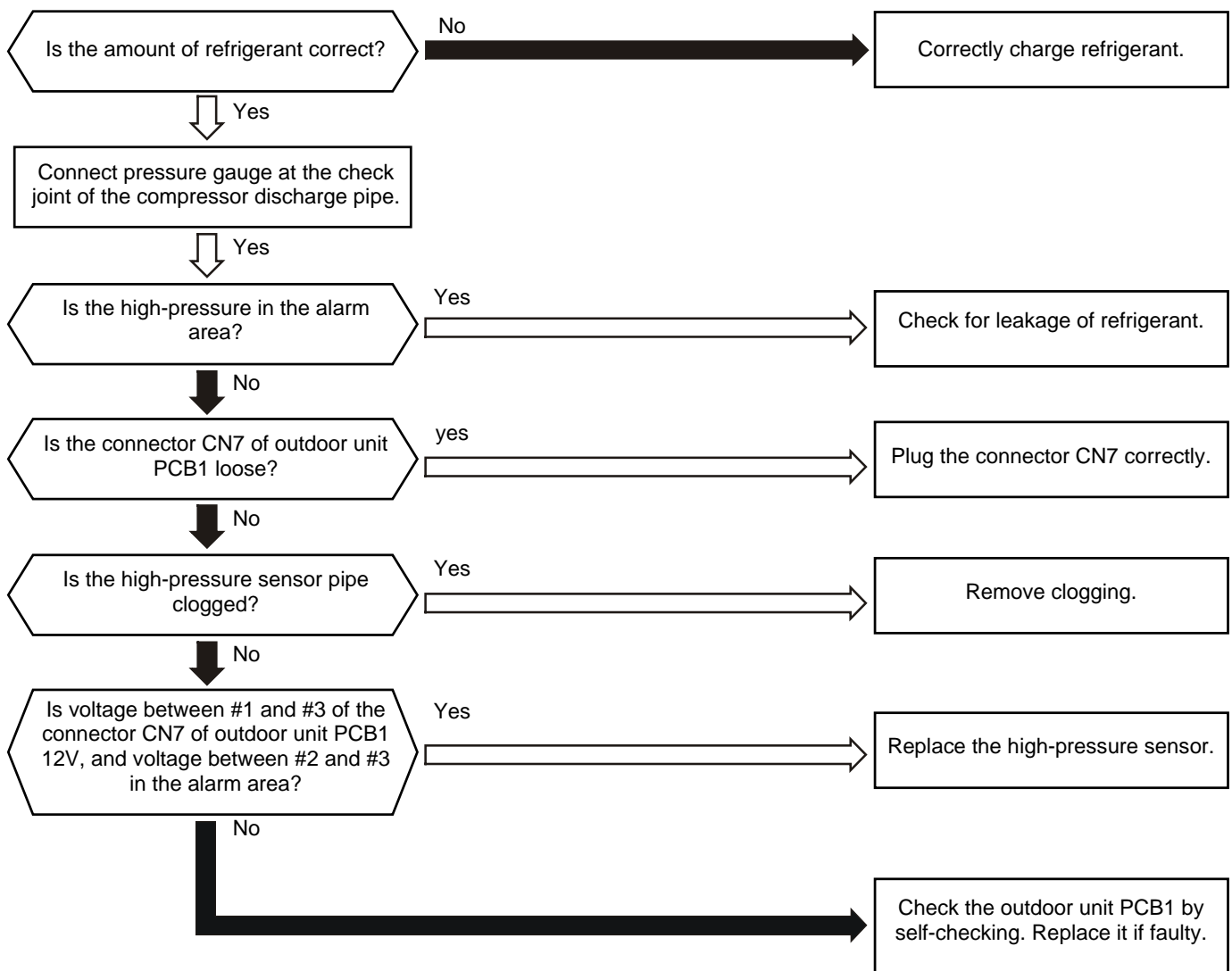
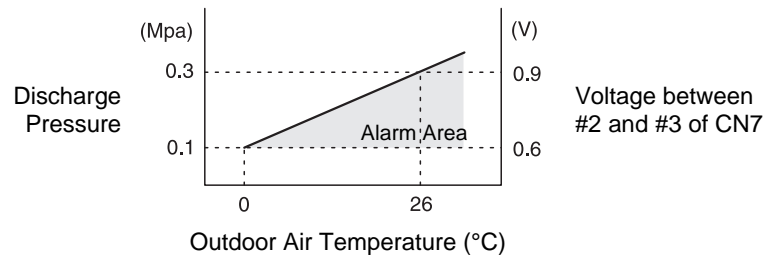

Alarm Code	47
Activation to Protect System from Excessively Low Suction Pressure (Protection from Vacuum Operation)	

- "RUN" light flickers and "ALARM" is indicated on the remote control switch.
- The unit No., alarm code and the unit code is alternately indicated on the set temperature section, and the unit No. and alarm code are indicated on the display of the outdoor unit PCB.
- ★ This alarm code is indicated when a suction pressure is lower than 0.02 MPa (0.2 kg/cm²G) for over 12 minutes and its state occurs more than 3 times including 3 in one hour.

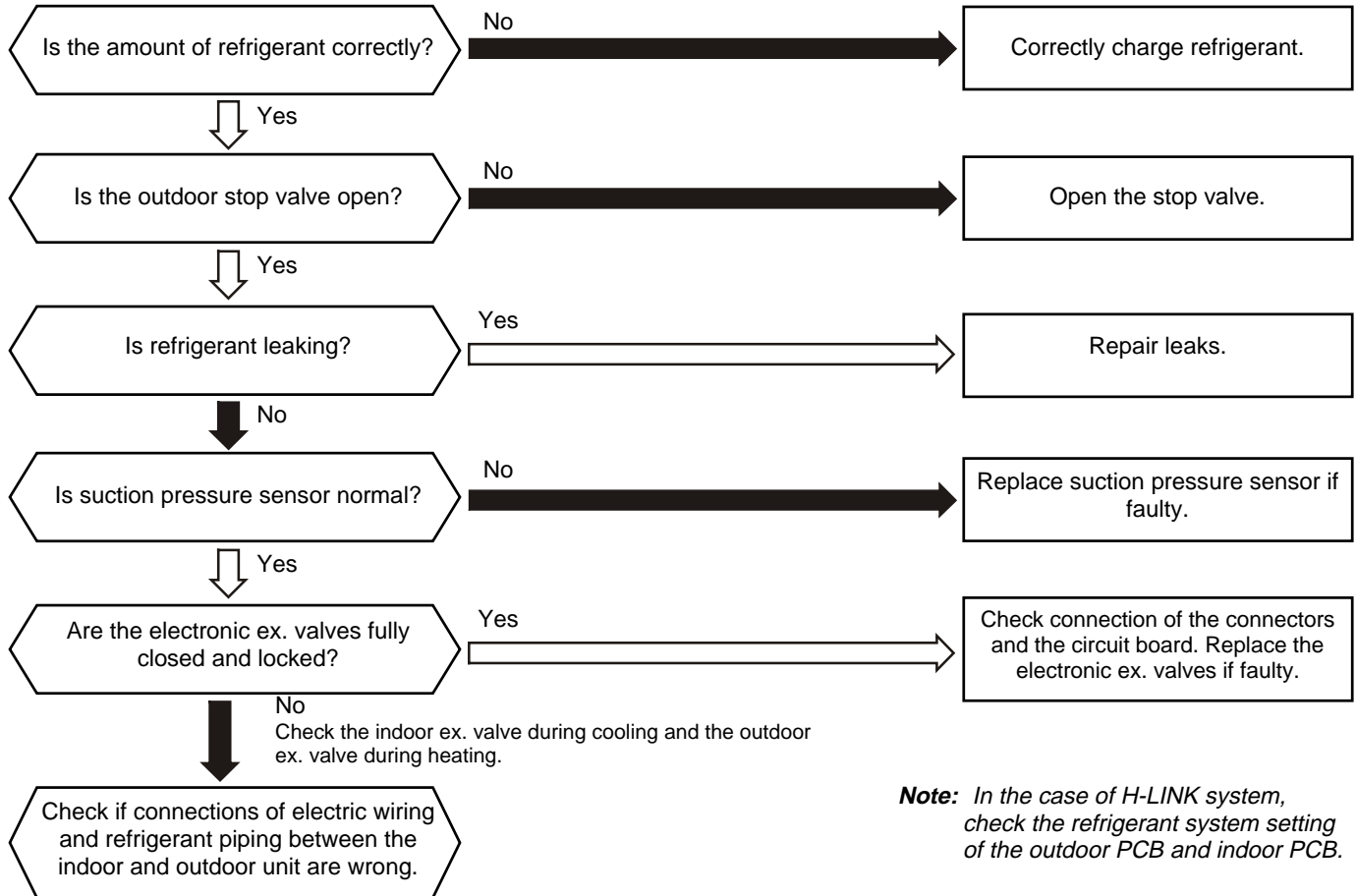

Note: In the case of H-LINK system, check the refrigerant system setting of the outdoor PCB and indoor PCB.

Phenomenon	Cause	Check Item	Action (Turn OFF main switch)
Excessively Low Suction Pressure (in Vacuum)	Shortage of Ref.	Check ref. charged volume or check for leakage.	Repair leakage and correctly charge.
	Closed Stop Valve	Check stop valve. .	Open stop valve.
	Abnormal Low or High Pressure Sensor	Check connector for PCB.	Replace pressure sensor if faulty.
	Incorrect Connection between Indoor Unit and Outdoor Unit	Check electrical system and ref. cycle.	Correctly connect between indoor unit and outdoor unit.
	Locked Ex. Valve	Check connector for PCB..	Repair or replace connector of PCB or ex. valve.

Alarm Code	
51	Abnormality of Current Transformer (0A Detection)

- "RUN" light flickers and "ALARM" is indicated on the remote control switch.
- The unit No., alarm code and the unit code is alternately indicated on the set temperature section, and the unit No. and alarm code are indicated on the display of the outdoor unit PCB.
- ★ This alarm code is indicated when the current transformer is abnormal (0A detection) and its state occurs more than 3 times in 30 minutes.

Condition of Activation: When the frequency of compressor is maintained at 15~18Hz after compressor is started, one of the absolute value of running current at each phase U+, U-, V+ and V- is less than 0.5A (including 0.5A).

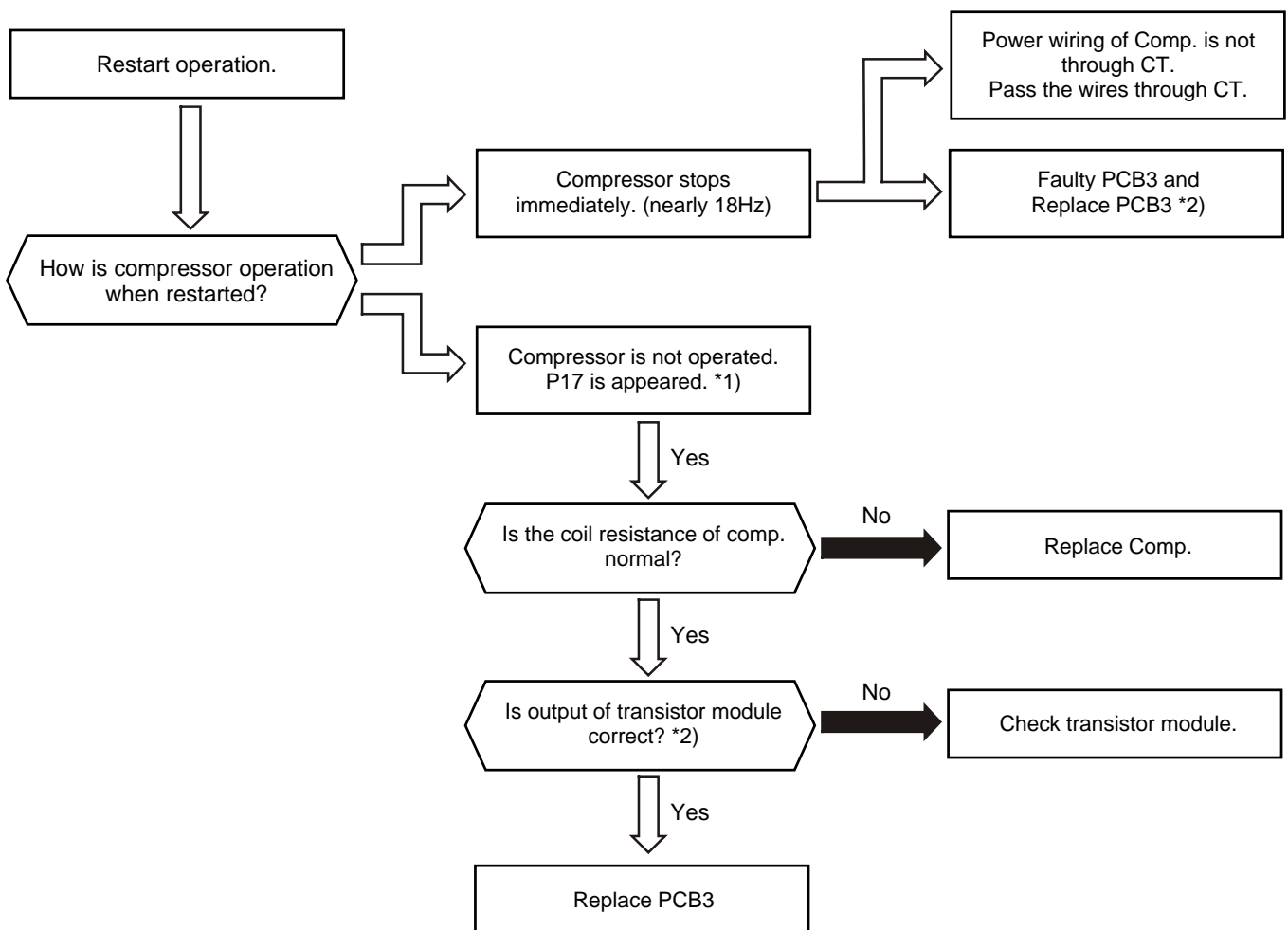

*1): P17 is shown at 7-segment on the outdoor unit PCB.

*2): Perform the high voltage discharge work by referring to 1.3.6 before checking and replacing the inverter parts.

Alarm Code

52

Protection Activation Against Instantaneous Overcurrent of Inverter (1)

- "RUN" light flickers and "ALARM" is indicated on the remote control switch.
- The unit No., alarm code and the unit code is alternately indicated on the set temperature section, and the unit No. and alarm code are indicated on the display of the outdoor unit PCB.
- ★ This alarm code is indicated when the electronic thermal relay for the inverter is activated 3 times including 3 in 30 minutes. Retry operation is performed up to the occurrence of 2 times.
Conditions: Inverter current with 105% of the rated current, ① runs continuously for 30 seconds or ② runs intermittently and the accumulated time reaches up to 3.5 minutes, in 10 minutes.

Model	Rated Current
	380-415V 50Hz
RAS-5FS3(G), RAS-8FS3(G), RAS-10FS3(G)	14.0 / 25.0
RAS-16FS3(G), RAS-20FS3(G)	16.5 / 30.0

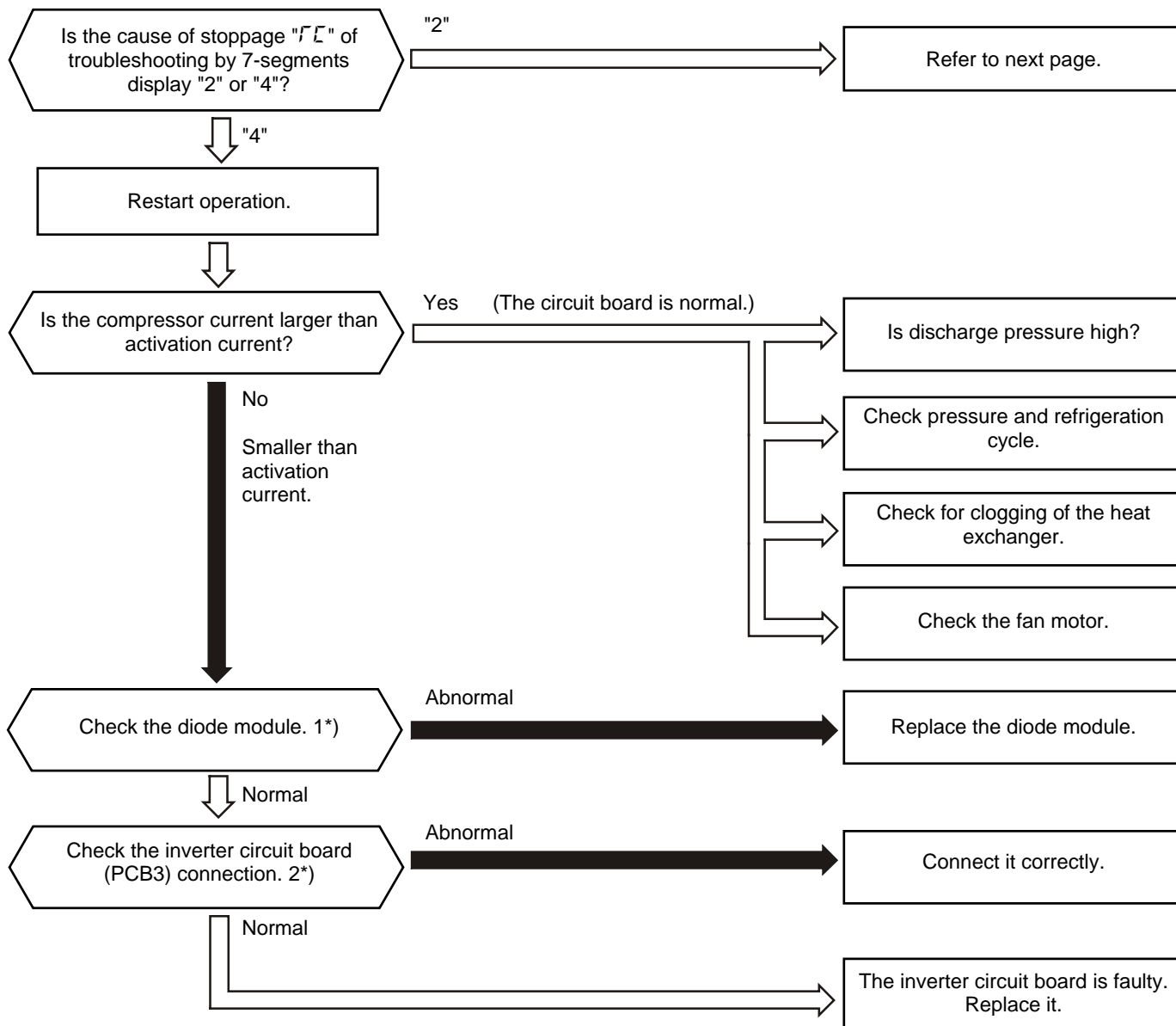

*1): Regarding the checking method for diode module, refer to page 1-92.

*2): Regarding or replacing the checking of inverter components, refer to page 1-90 regarding electrical discharge.

Alarm Code	
52	Protection Activation Against Instantaneous Overcurrent of Inverter (2)

- "RUN" light flickers and "ALARM" is indicated on the remote control switch.
- The unit No., alarm code and the unit code is alternately indicated on the set temperature section, and the unit No. and alarm code are indicated on the display of the outdoor unit PCB.
- ★ This alarm code is indicated when the instantaneous overcurrent tripping occurs 3 times including 3 in 30 minutes. Retry operation is performed up to the occurrence of 2 times.
Conditions: Inverter current is 150% of the rated current.

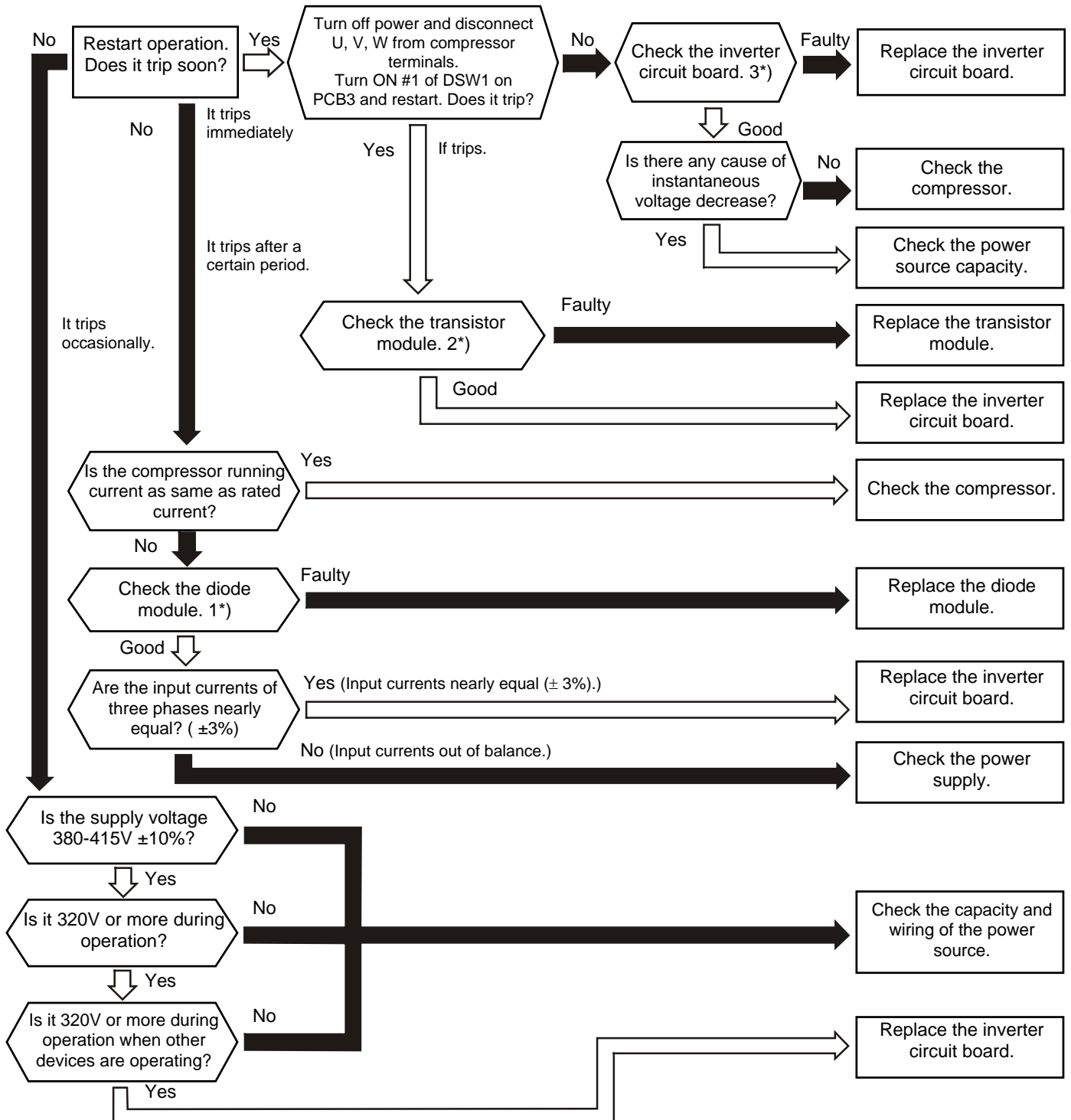

1*): Regarding or replacing the checking method for the diode module, refer to page 1-92.

2*): Regarding the checking method for transistor module, refer to page 1-91.

3*): Regarding the checking of inverter components, refer to page 1-90 regarding electrical discharge.

Alarm Code	
53	Protection Activation of Transistor Module

- "RUN" light flickers and "ALARM" is indicated on the remote control switch.
- The unit No., alarm code and the unit code is alternately indicated on the set temperature section, and the unit No. and alarm code are indicated on the display of the outdoor unit PCB.
- ★ Transistor module have detecting function of abnormality. This alarm is indicated when the transistor module detect the abnormality 3 times in 30 minutes including 3. Retry operation is performed up to the occurrence of 2 times.
Conditions: Abnormal Current to the Transistor Module such as Short Circuited or Grounded or Abnormal Temperature of the Transistor Module or Control Voltage Decrease

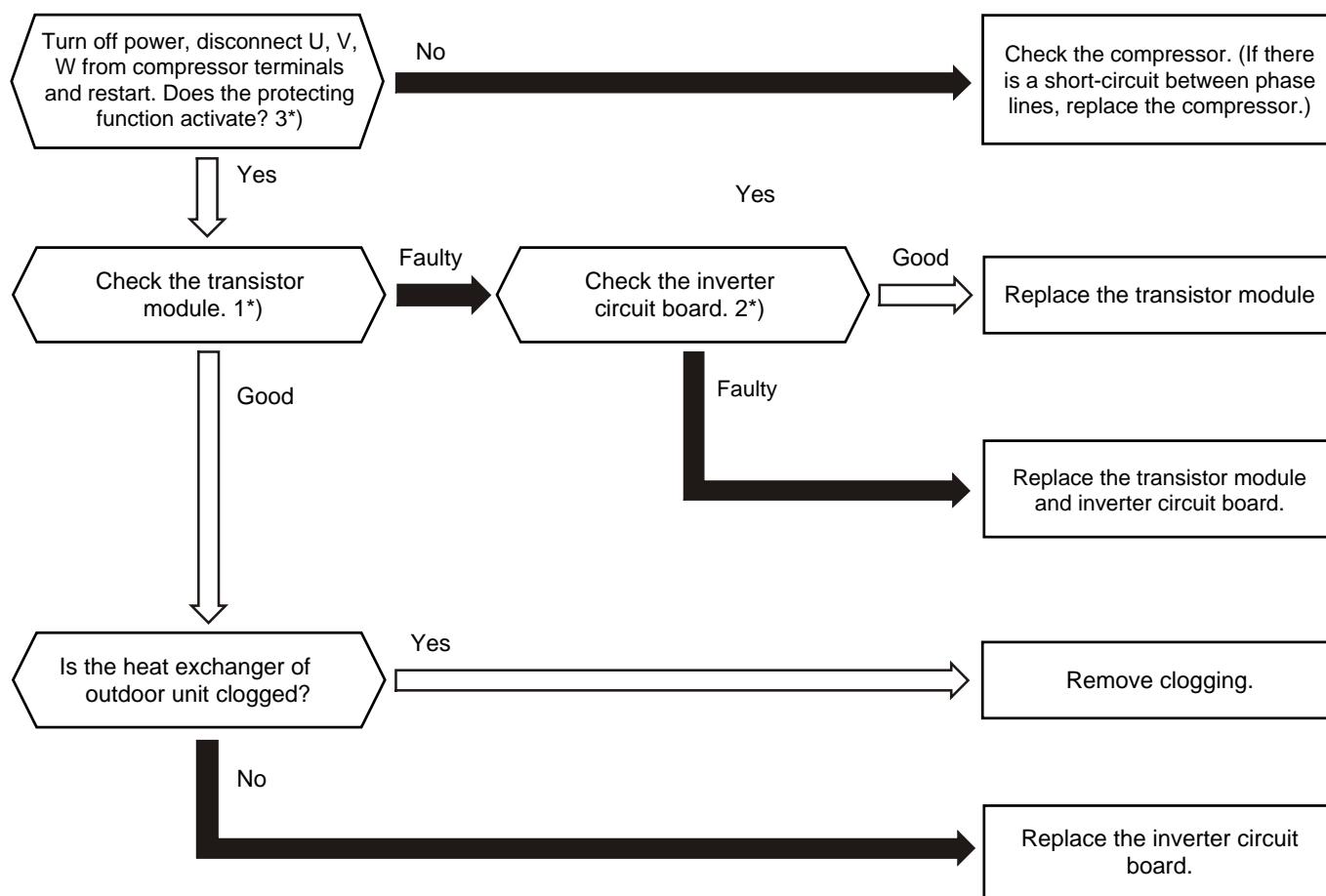

1*): Regarding replacing or checking method for the transistor module, refer to page 1-91.

2*): Regarding the checking of inverter components, refer to page 1-90 regarding electrical discharge.

3*): Turn ON #1 of the dip switch DSW1 on PCB3 when restarting with disconnecting the terminals of the compressor.

After troubleshooting, turn OFF #1 of the dip switch DSW1 on PCB3.

Alarm Code	
59	Abnormality of AC Chopper Circuit Board

- "RUN" light flickers and "ALARM" is indicated on the remote control switch.
- The unit No., alarm code and the unit code is alternately indicated on the set temperature section, and the unit No. and alarm code are indicated on the display of the outdoor unit PCB.
- ★ This alarm code is indicated when a current value of AC chopper becomes ① less than 0.5A when outdoor unit fan is operating, or ② more than 2A while outdoor unit fan stops.

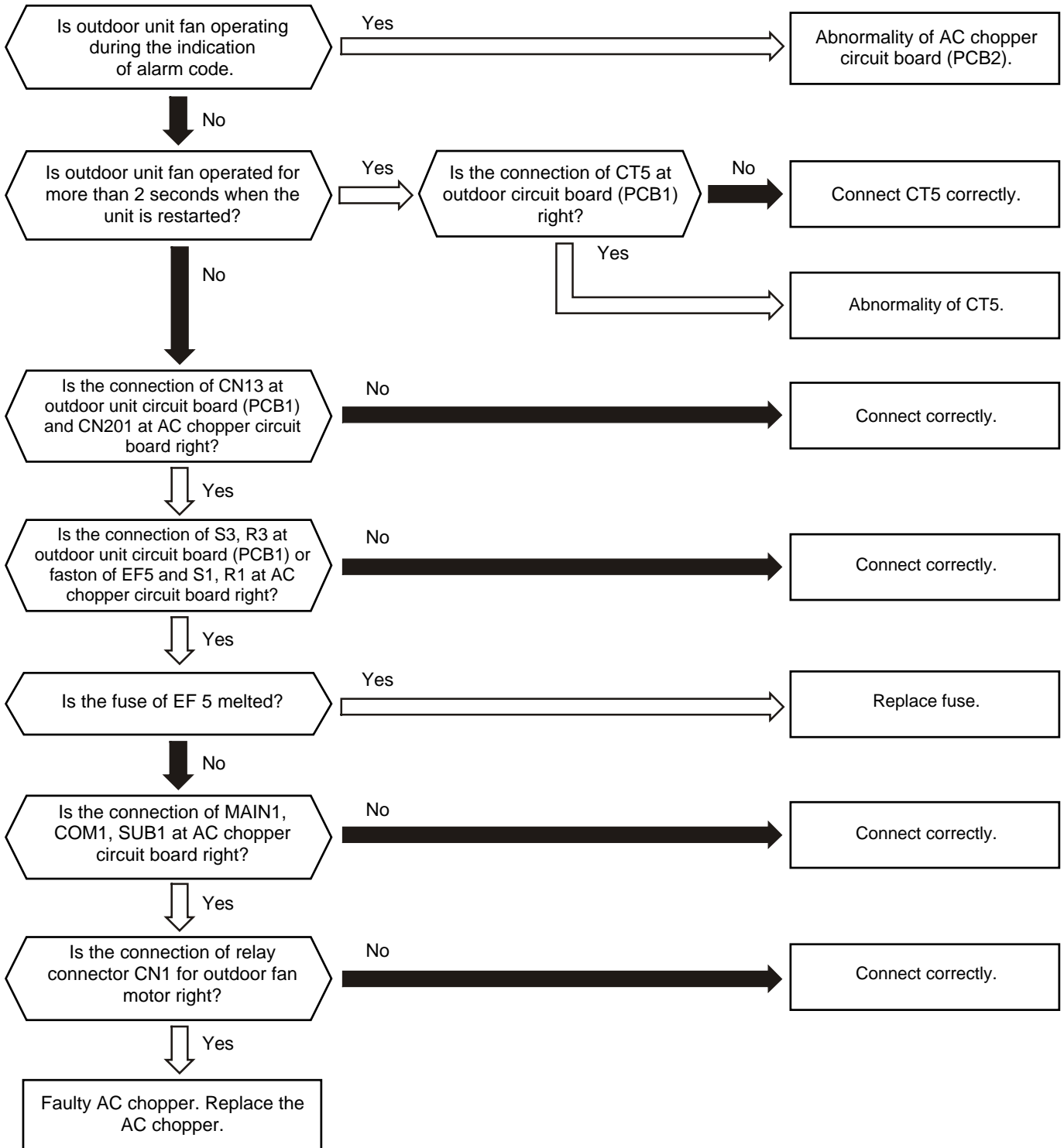

Alarm Code	Incorrect Wiring Among Indoor Units
dd	

- ★ This alarm code is indicated only when remote control switch PC-2H2 is used being connected to indoor unit.
- ★ This alarm occurs in the case of incorrect connection like that TL terminal is connected to Vc terminal as below when indoor units are wired.

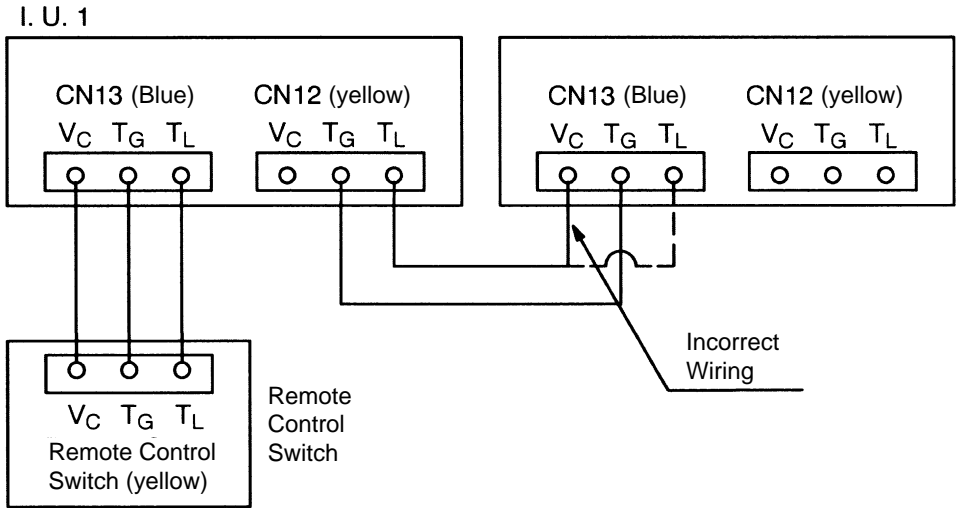

The unit No. and unit code are as below regardless of the indoor unit.	
Unit No.	dd
Cycle System	dd
Unit Code	Edd



Yes

Turn off the main powerswitch and cut the wire JP4 at remote control switch, then turn on the main power switch again.

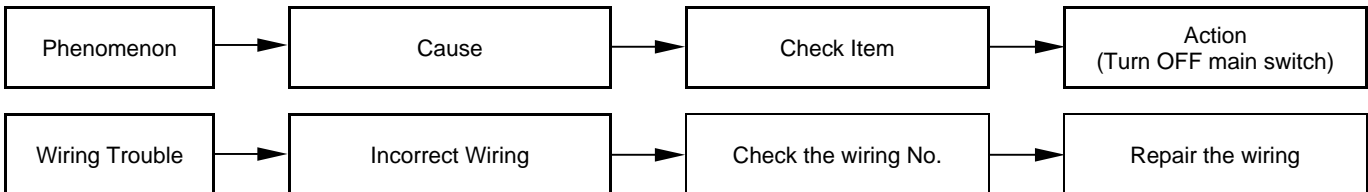
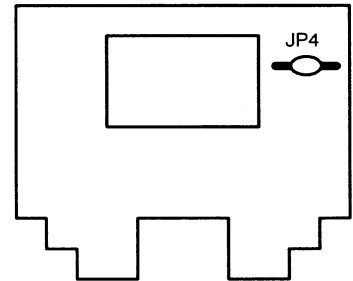

Alarm Code	Compressor Protection
EE	

- ★ This alarm code appears when one of the following alarms occurs three times within 6 hours, which may result in serious compressor damages, if the outdoor unit is continuously operated without removing the cause.

Alarm Code:	Content of Abnormality
02	Tripping of Protection Device in Outdoor Unit
07	Decrease in Discharge Gas Superheat
08	Increase in Discharge Gas Temperature
39	Abnormality of Running Current at Constant Comp.
43	Pressure Ratio Decrease Protection Activating
44	Low Pressure Increase Protection Activating
45	High Pressure Increase Protection Activating
46	High Pressure Decrease Protection Activating
47	Low Pressure Decrease Protection Activating

These alarms are able to be checked by the CHECK Mode 1. Follow the action indicated in each alarm chart. These alarms are cleared only by turning OFF the main power switch to the system. **However, careful attention is required before starting, since there is a possibility which will result in serious damages to the compressors.**

1.2.3 TROUBLESHOOTING IN CHECK MODE BY REMOTE CONTROL SWITCH

- Use the remote control CHECK switch in the following cases.
 1. When the RUN lamp is flashing
 2. To trace back the cause of trouble after restarting from stoppage with the RUN lamp flashing
 3. To check during normal operation or stoppage
 4. To monitor the temperature of intake and discharge.

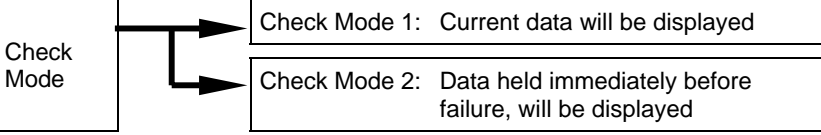
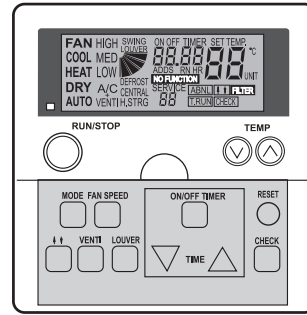

- Indication will delay as transmission between the remote control switch and indoor unit takes about 10 seconds.
- All data may be displayed as "FF" or "- I" or "255". These transient data produced temporarily by software do not affect device functions at all. (The alarm code may also be indicated as "FF".)

Normal Mode

Unit number and Alarm Code Displayed

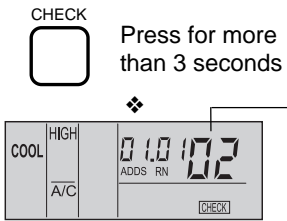

Alarm code identifying the last fault that has occurred in the indicated unit.
Unit number of connected unit or unit number for which checking mode was selected previously.

Perform within 7 seconds to check another unit

❖ ADDS: Number of Indoor Unit in No. ** Cycle
RN: No. ** Refrigerant Cycle

After 7 seconds
Check Mode 1
(See page 1-63 for details)

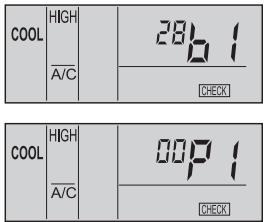

- Forward: Press the switch to rise from 00 to 01 to 02 ...
- Backward: Press the switch to descend from 15 to 14 to 13 ...

Press to view the previous indication
Press to view the next indication

Unit number and Alarm Code Displayed

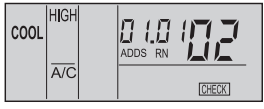

Press to view the next data
Press to view the previous data

See (A)
After 7 seconds
Check Mode 2
(See page 1-66 for details)

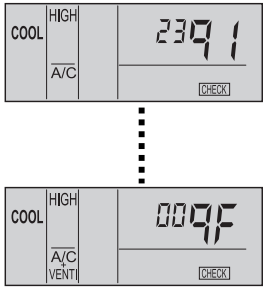

Press

- In Check Mode 2, data of the first three units connected serially to a remote control switch are available.
- You can press the CHECK switch to release Check Mode 2. Check Mode 1 cannot be released even if you press CHECK switch.

Check Mode released

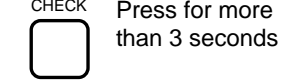

■ CONTENTS OF CHECK MODE 1

The next indication is shown by pressing the part \odot of "TEMP" switch. If the part \checkmark of "TEMP" switch is pressed, the previous indication is shown.

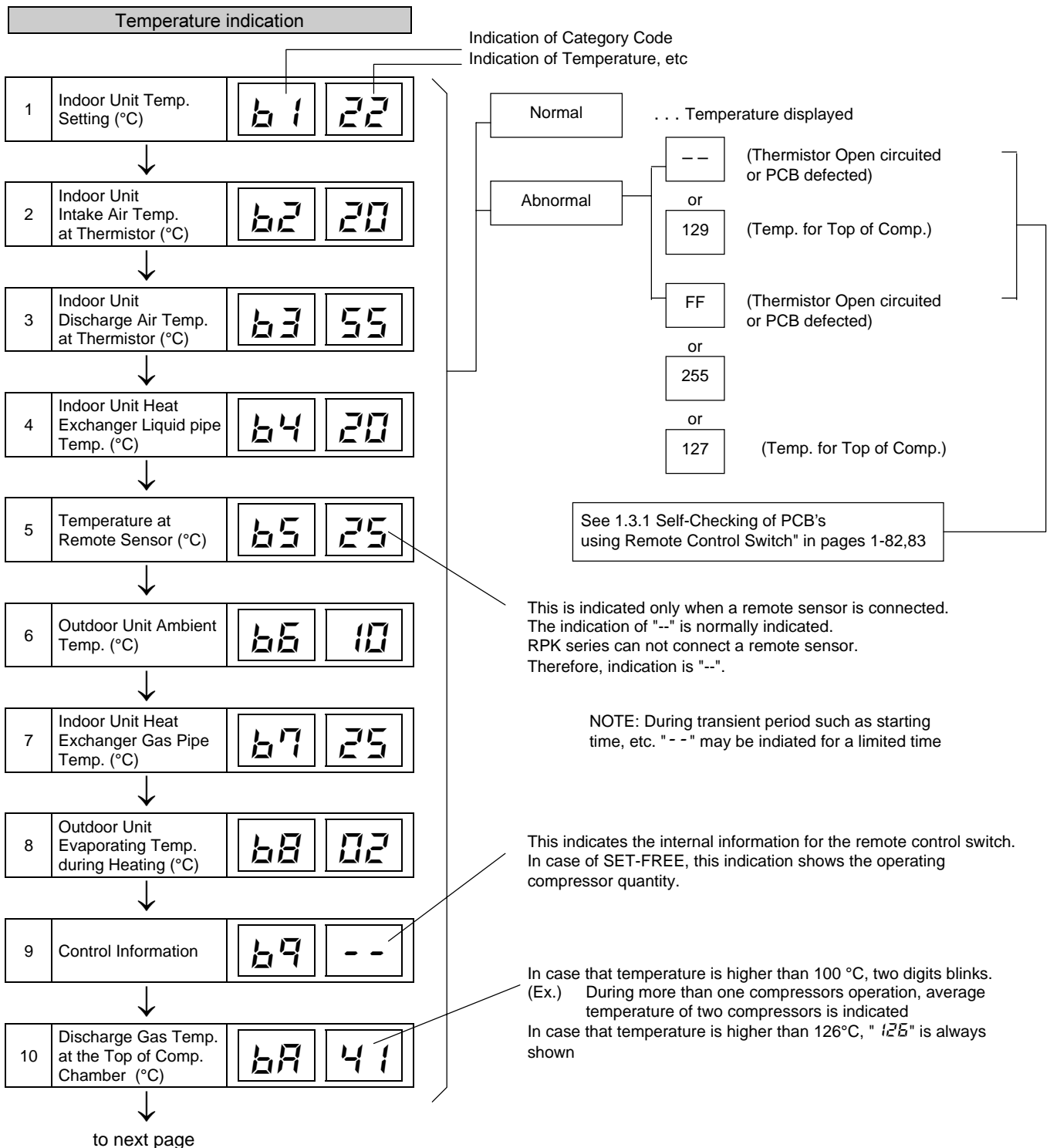

11	Thermo Temp. of Remote Control Switch	bb	23
----	---------------------------------------	----	----

Indication on Micro-Computer Input /Output

12	Micro Computer Input/Output in Indoor Unit	E1	4
----	--------------------------------------------	----	---

13	Micro Computer Input/Output in Outdoor Unit	E2	-
----	---------------------------------------------	----	---

Indication of Unit Stoppage cause

14	Cause of Stoppage	d1	01
----	-------------------	----	----

Abnormality Occurrence Counter

15	Abnormality Occurrence Times	E1	01
----	------------------------------	----	----

16	Instantaneous Power Failure Occurrence Times in Indoor Unit	E2	00
----	-------------------------------------------------------------	----	----

17	Transmission Error Occurrence Times between Remote Control Switch and Indoor Unit	E3	00
----	-----------------------------------------------------------------------------------	----	----

18	Abnormality Occurrence Times on Inverter	E4	00
----	------------------------------------------	----	----

Indication of Automatic Louver Condition

19	Louver Sensor	F1	00
----	---------------	----	----

to next page

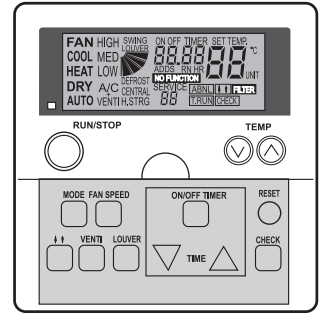
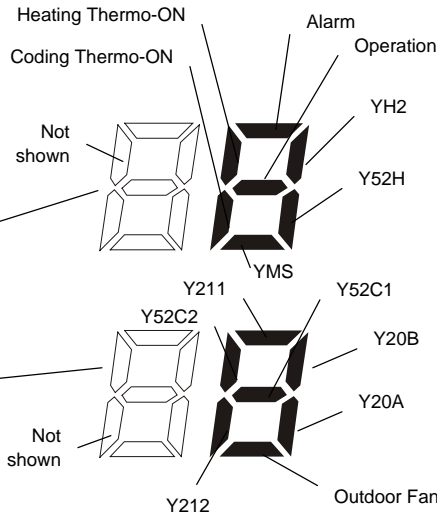

Symbols with a letter Y are relays on PCB

00	Operation OFF, Power OFF
01	Thermo - OFF (Note 1)
02	Alarm (Note 2)
03	Freeze Protection, Overheating Protection
05	Instantaneous Power Failure at Outdoor Unit, Reset (Note 3)
06	Instantaneous Power Failure at Indoor Unit, Reset (Note 4)
07	Stoppage of Cooling Operation due to Low Outdoor Air Temperature, Stoppage of Heating Operation due to High Outdoor Air Temperature
08	Compressor Quantity Changeover, Stoppage (HP≥8)
09	Demand of 4-Way Valve Changeover Stoppage (FX Only)
10	Demand, Enforced Stoppage
11	Retry due to Pressure Ratio Decrease
12	Retry due to Low Pressure Increase
13	Retry due to High Pressure Increase
14	Retry due to Abnormal Current of Constant Compressor (HP≥8)
15	Retry due to Abnormal High Temperature of Discharge Gas, Excessively Low Suction Pressure
16	Retry due to Decrease of Discharge Gas Superheat
17	Retry due to Inverter Tripping
18	Retry due to Voltage Decrease
19	Expansion Valve Opening Change Protection
20	Operation Mode Changeover of Indoor Unit (Note 5)

Note 1: Explanation of Terms

Thermo-ON: A condition than an Indoor Unit is requesting compressor to operate.

Thermo - OFF: A condition than an Indoor Unit is not requesting compressor to operate.

Note 2: Even if stoppage is caused by "Alarm", "02" is not always indicated.

Note 3: If transmission between the inverter printed circuit board and the control printed circuit board is not performed during 30 seconds, stoppage is d1-05 cause and the alarm code "04" may be indicated.

Note 4: If transmission between the Indoor Unit and the Outdoor Unit is not performed during 3 minutes, Indoor Units are stopped. In this case, stoppage is d1-06 cause and the alarm code "03" may be indicated.

Note 5: In the FSG and FS3 system "20" will be indicated at the difference mode between Indoor Units.

Countable up to 99.

Over 99 times, "99" is always indicated.

Note 1: If a transmitting error continues for 3 minutes, one is added to the occurrence times.

Note 2: The memorized data can be cancelled by the method indicated in 1.3.1. "Self-checking of PCBs using Remote Control Switch"

00 : Normal
FF : Abnormal

Compressor Pressure/Frequency Indication

20 Discharge Pressure (High) (X 0.1 MPa) **H1 18**



21 Suction Pressure (Low) (X 0.01 MPa) **H2 04**



22 Control Information **H3 44**

This is an indication for internal information for the remote control switch. This does not have any specific meaning.



23 Operation Frequency (Hz) **H4 44**

The total frequency is indicated when plural compressors are running



Indoor Unit Capacity Indication

24 Indoor Unit Capacity **J1 08**

The capacity of the Indoor Unit is indicated as shown in the table below.

Capacity Code of Indoor Unit

Indication Code	Equivalent Capacity (HP)
06	0.8
08	1.0
10	1.3
13	1.5
14	1.8
16	2.0
18	2.3
20	2.5
22	2.8
26	3.0
32	4.0
40	5.0



25 Outdoor Unit Code **J2 Fn**

"n" indicates total number of Indoor Units;
n= 1~9, A, b, C, d, E, F, U
(10) (11) (12) (13) (14) (15) (16)



26 Refrigerant Cycle Number **J3 01**

J3: 01 ~ 16 (01: of shipment (DSW5),
Decimal indication)



27 Refrigerant Cycle Number **J4 00**

J4: 00 ~ 0F (00: of shipment (DSW5),
Indication with 16 numbers Hexadecimal indication)



Expansion Opening Indication

28 Indoor Unit Expansion Valve Opening (%) **L1 20**



29 Outdoor Unit Expansion Valve MV1 Opening (%) **L2 99**

In case of models without Expansion Valve (MV2), the same figure is indicated



30 Outdoor Unit Expansion Valve MV2 Opening (%) **L3 99**



31 Control Information **L4 00**



Estimated Electric Current Indication

32 Compressor Running Current (A) **P1 25**

The total current is indicated when plural compressors are running.
In case of inverter compressor, the running current of primary side of inverter is indicated

Returns to Temperature Indication

Temperature Indication

■ CONTENTS OF CHECK MODE 2

The latest data of the first three indoor units only connected serially are indicated when more than three indoor units are connected to one remote control switch.

By pressing the \odot part of "TEMP" switch, the next display is indicated. If the part \ominus of "TEMP" switch is pressed, the previous display is indicated.

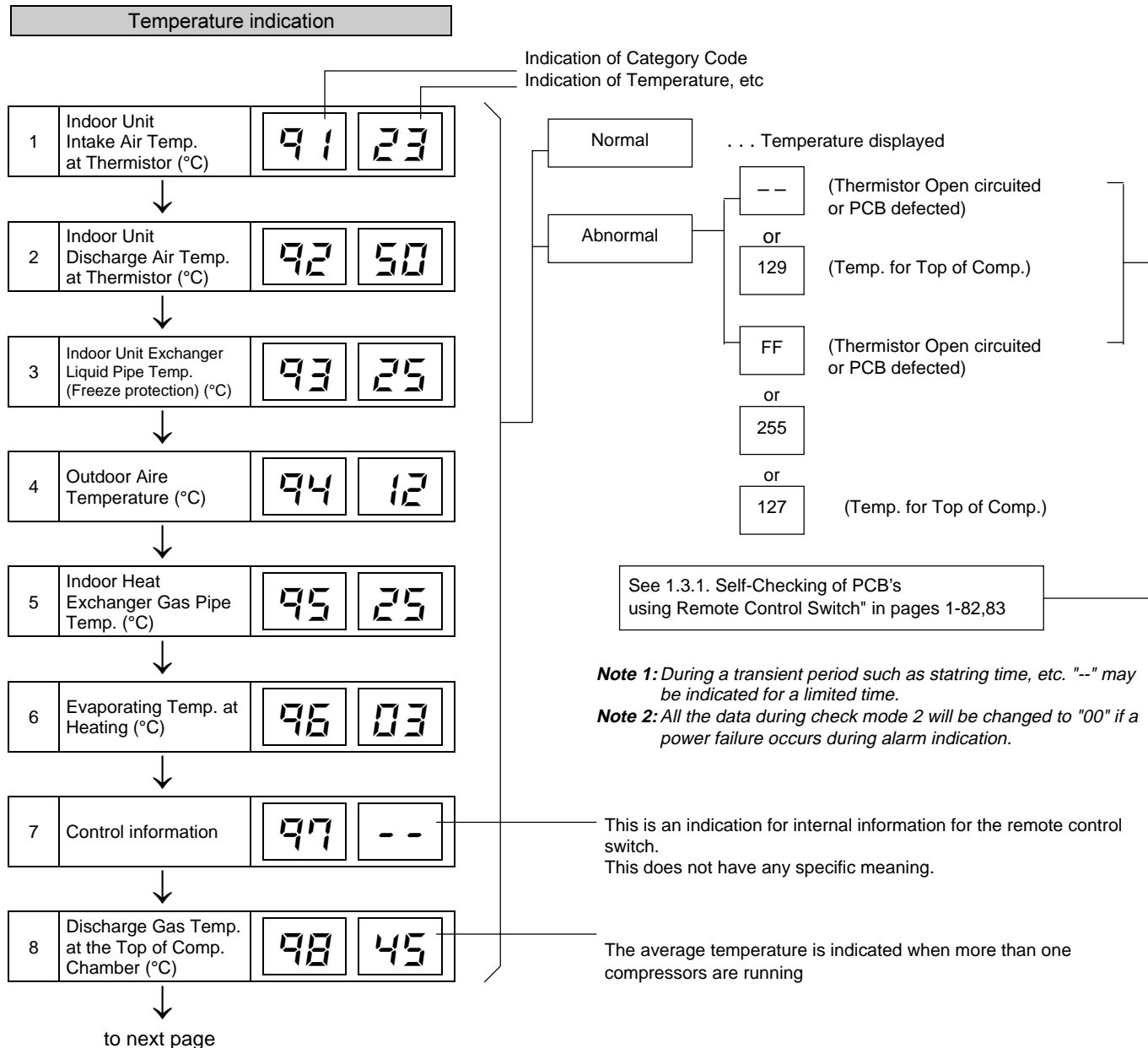

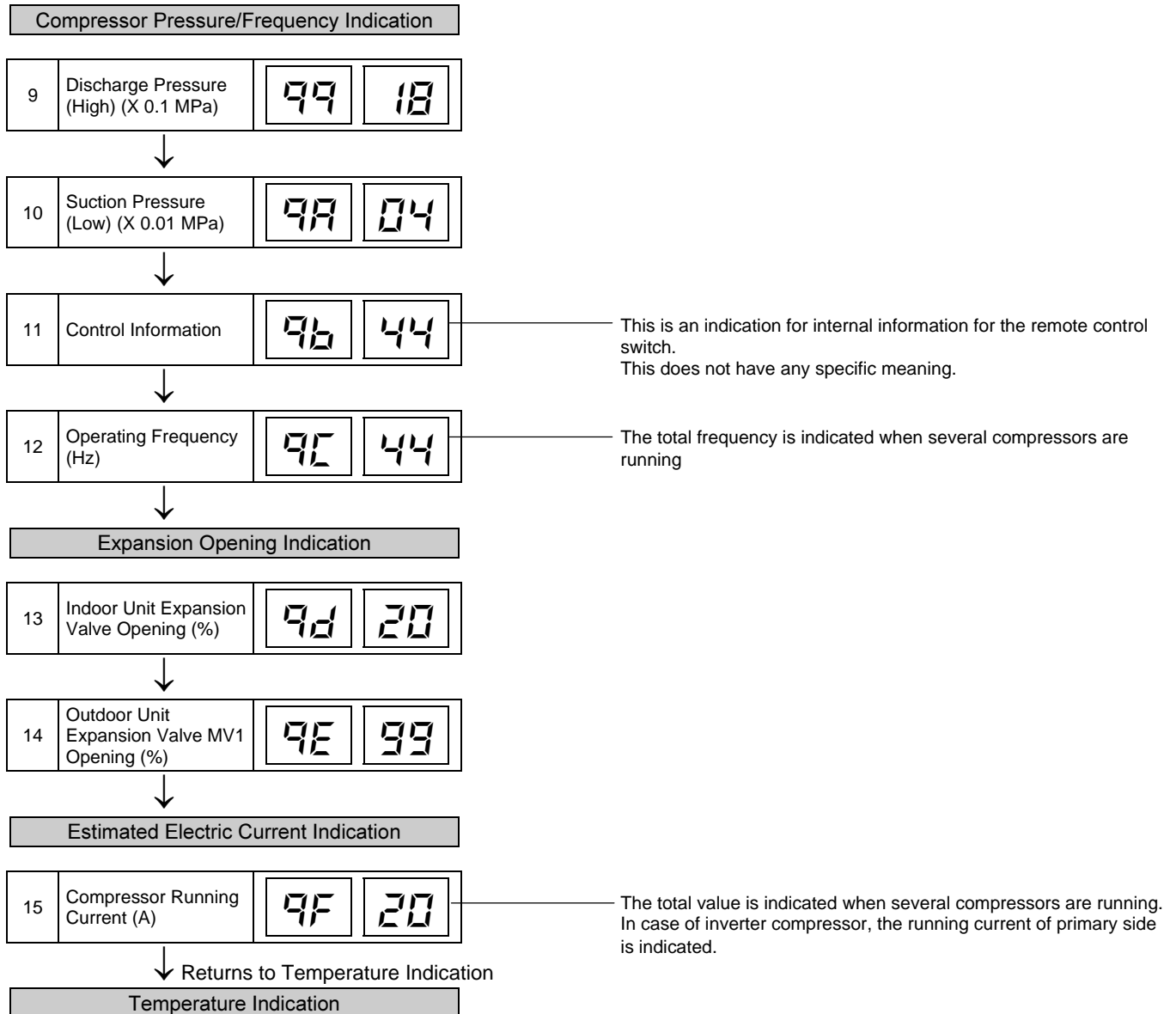

1.2.4 TROUBLESHOOTING BY 7-SEGMENT DISPLAY

■ CHECKING METHOD BY 7-SEGMENT DISPLAY

By using the 7-segments and check switch (PSW) on the PCB1 in the Outdoor Unit, total quantity of combined Indoor Units, 7-segments operation conditions and each part of refrigerant cycle can be checked.

PSW

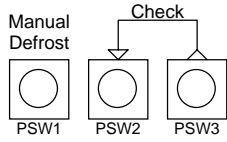

7-Segments

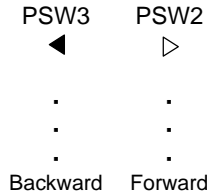
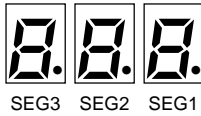

- To start checking, press the "PSW2" switch for more than 3 seconds.
- To proceed checking, press the "PSW2" switch for less than 2 seconds.
- To proceed reversely, press the "PSW3" for less than 2 seconds.
- To cancel this checking, press the "PSW2" switch for more than 3 seconds. The display will be changed to the indication one step before. Then, press the PSW2 switch once again for more than 3 seconds.

Checking Item

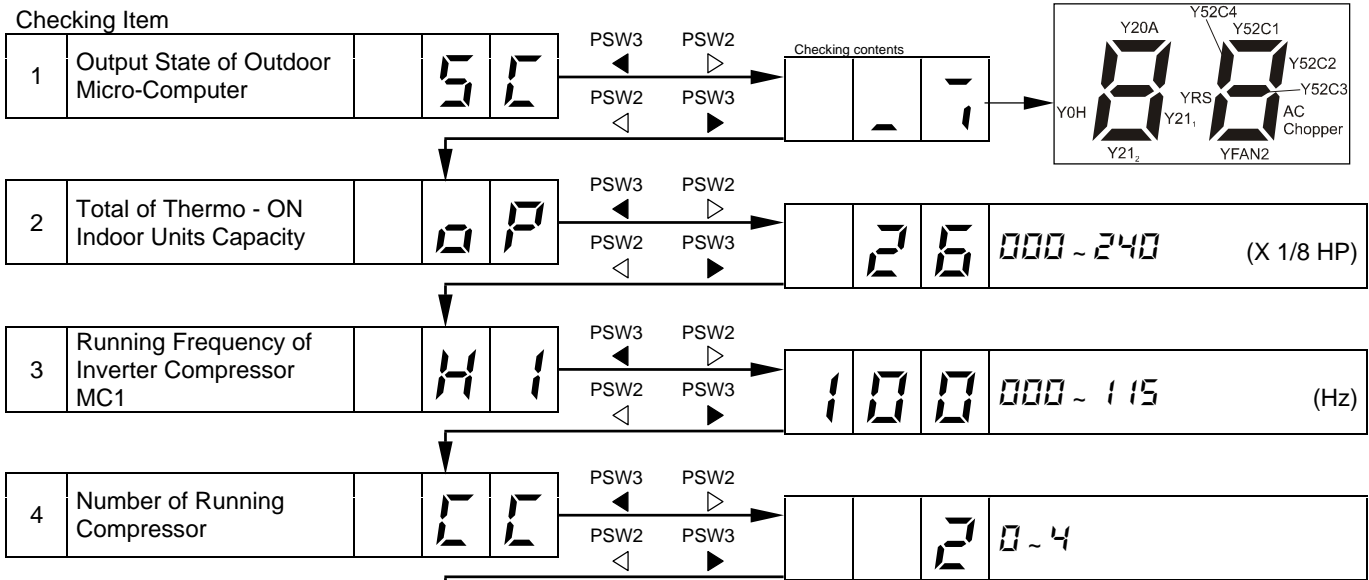

to next page

from Previous Page

Checking item

5	Air flow ratio	F 0	PSW3 PSW2 PSW2 PSW3	PSW2 PSW3 PSW3 PSW2	Checking contents	150 ~ 16	
6	Outdoor Expansion Valve MV1 Opening	0 E 1	PSW3 PSW2 PSW2 PSW3	PSW2 PSW3 PSW3 PSW2		380 ~ 100	(%)
7	Outdoor Expansion Valve MV2 Opening	0 E 2	PSW3 PSW2 PSW2 PSW3	PSW2 PSW3 PSW3 PSW2		1000 ~ 100	(%)
8	Discharge Pressure (High)	P d	PSW3 PSW2 PSW2 PSW3	PSW2 PSW3 PSW3 PSW2		1.800 ~ 3.0	(MPa)
9	Suction Pressure (Low)	P S	PSW3 PSW2 PSW2 PSW3	PSW2 PSW3 PSW3 PSW2		0.34009 ~ 0.99	(MPa)
10	Discharge Gas Temp. on the Top of Compressor MC1 (TD1)	T d 1	PSW3 PSW2 PSW2 PSW3	PSW2 PSW3 PSW3 PSW2	\square = Open Circuited , 255 = Short - circuited	1001 ~ 142	(°C)
11	Discharge Gas Temp. on the Top of Compressor MC2 (TD2) <small>(For 8, 10, 16, 20HP)</small>	T d 2	PSW3 PSW2 PSW2 PSW3	PSW2 PSW3 PSW3 PSW2	\square = Open Circuited , 255 = Short - circuited	901 ~ 142	(°C)
12	Discharge Gas Temp. on the Top of Compressor MC3 (TD3) <small>(For 16, 20HP)</small>	T d 3	PSW3 PSW2 PSW2 PSW3	PSW2 PSW3 PSW3 PSW2	\square = Open Circuited , 255 = Short - circuited	1001 ~ 142	(°C)
13	Discharge Gas Temp. on the Top of Compressor MC4 (TD4) <small>(For 20HP)</small>	T d 4	PSW3 PSW2 PSW2 PSW3	PSW2 PSW3 PSW3 PSW2	\square = Open Circuited , 255 = Short - circuited	901 ~ 142	(°C)
14	Evaporating Temperature 1 at Heating	T E 1	PSW3 PSW2 PSW2 PSW3	PSW2 PSW3 PSW3 PSW2	- i2 ⁿ = Open Circuited , i2 ⁿ = Short - circuited	6 - 42 ~ 88	(°C)
15	Evaporating Temperature 2 at Heating <small>(For 16, 20HP)</small>	T E 2	PSW3 PSW2 PSW2 PSW3	PSW2 PSW3 PSW3 PSW2	- i2 ⁿ = Open Circuited , i2 ⁿ = Short - circuited	2 - 42 ~ 80	(°C)
16	Ambient Air Temperature (TO)	T 0	PSW3 PSW2 PSW2 PSW3	PSW2 PSW3 PSW3 PSW2	- i2 ⁿ = Open Circuited , i2 ⁿ = Short - circuited	35 - 42 ~ 80	(°C)

to next page

from Previous Page

Checking item

17	Estimated Running Current of Compressor MC1	(No. 0 Unit)	A 1	PSW3 PSW2	PSW2 PSW3	Indicates running current of primary side of inverter	1 0 000 ~ 255	(A)
		(No. F Unit)						

18	Estimated Running Current of Compressor MC2 <small>(For 8, 10, 16, 20HP)</small>	(No. 0 Unit)	A 2	PSW3 PSW2	PSW2 PSW3		1 2 000 ~ 255	(A)
		(No. F Unit)						

19	Estimated Running Current of Compressor MC3 <small>(For 16, 20HP)</small>	(No. 0 Unit)	A 3	PSW3 PSW2	PSW2 PSW3		1 3 000 ~ 255	(A)
		(No. F Unit)						

20	Estimated Running Current of Compressor MC4 <small>(For 20HP)</small>	(No. 0 Unit)	A 4	PSW3 PSW2	PSW2 PSW3		1 2 000 ~ 255	(A)
		(No. F Unit)						

21	Indoor Unit Expansion Valve Opening	(No. 0 Unit)	1 E 0	PSW3 PSW2	PSW2 PSW3		1 2 (No. 0 Unit) 0 ~ 100	(%)	
		~	↓	~					
		(No. F Unit)	1 E F	PSW3 PSW2	PSW2 PSW3				1 0 (No. F Unit) 0 ~ 100

(Indicates only the units number connected)

22	Indoor Unit Heat Exchanger Liquid Pipe Temp. (Freeze protection)	(No. 0 Unit)	1 L 0	PSW3 PSW2	PSW2 PSW3		1 2 (No. 0 Unit) -62 ~ 127	(°C)	
		~		~					
		(No. F Unit)	1 L F	PSW3 PSW2	PSW2 PSW3				1 2 (No. F Unit) -62 ~ 127

(Indicates only the units number connected)

23	Indoor Unit Heat Exchanger Gas Pipe Temp.	(No. 0 Unit)	1 G 0	PSW3 PSW2	PSW2 PSW3		1 7 (No. 0 Unit) -62 ~ 127	(°C)	
		~		~					
		(No. F Unit)	1 G F	PSW3 PSW2	PSW2 PSW3				1 7 (No. F Unit) -62 ~ 127

(Indicates only the units number connected)

24	Indoor Unit Intake Air Temperature.	(No. 0 Unit)	1 , 0	PSW3 PSW2	PSW2 PSW3		2 7 (No. 0 Unit) -62 ~ 127	(°C)	
		~		~					
		(No. F Unit)	1 , F	PSW3 PSW2	PSW2 PSW3				2 7 (No. F Unit) -62 ~ 127

(Indicates only the units number connected)

to next page

from Previous Page

Checking item

25	Indoor Unit Discharge Air Temperature.	(No. 0 Unit)	1 7 0	PSW3 ← PSW2 →	1 7	(No. 0 Unit)	-62 ~ 127	(°C)
		~		PSW2 ← PSW3 →				
		(No. F Unit)	1 7 F	PSW3 ← PSW2 →	1 7	(No. F Unit)	-62 ~ 127	(°C)
				PSW2 ← PSW3 →				

(Indicates only the units number connected)

26	Indoor Unit Capacity Setting.	(No. 0 Unit)	C A 0	PSW3 ← PSW2 →		(No. 0 Unit)		(X 1/8 HP)
		~		PSW2 ← PSW3 →		8		
		(No. F Unit)	C A F	PSW3 ← PSW2 →		(No. F Unit)		(X 1/8 HP)
				PSW2 ← PSW3 →		2 0		

(Indicates only the units number connected)

Refer to the "Capacity Code of Indoor Unit" table for the capacity code indication, page 1-65

27	Indoor Unit Cause of Stoppage	(No. 0 Unit)	d 1 0	PSW3 ← PSW2 →		(No. 0 Unit)	0 ~ 80
		~		PSW2 ← PSW3 →		1	
		(No. F Unit)	d 1 F	PSW3 ← PSW2 →		(No. F Unit)	0 ~ 80
				PSW2 ← PSW3 →		1	

(Indicates only the units number connected)

Refer to the "Cause of Stoppage" table, for the code indication at page 1-64

28	Pressure Ratio Fall Protection Restricted Control		c 1 1	PSW3 ← PSW2 →		0	0: Restricted Control is not in Operation 1: Restricted Control is in Operation
				PSW2 ← PSW3 →			

29	High-Pressure Rise Protection restricted Control		c 1 3	PSW3 ← PSW2 →		1	0: Restricted Control is not in Operation 1: Restricted Control is in Operation
				PSW2 ← PSW3 →			

30	Discharge Gas Temp. Decrease Protection Restricted Control		c 1 5	PSW3 ← PSW2 →		0	0: Restricted Control is not in Operation 1: Restricted Control is in Operation
				PSW2 ← PSW3 →			

31	Discharge Gas Temp. Increase Protection Restricted Control		c 1 6	PSW3 ← PSW2 →		0	0: Restricted Control is not in Operation 1: Restricted Control is in Operation
				PSW2 ← PSW3 →			

32	Current Protection Restricted Control		c 1 7	PSW3 ← PSW2 →		0	0: Restricted Control is not in Operation 1: Restricted Control is in Operation
				PSW2 ← PSW3 →			

33	Total Accumulated hours of Compressor MC1		4 4 1	PSW3 ← PSW2 →	4 8 3	0 ~ 9999	(x 10 times hours)
				PSW2 ← PSW3 →			

Displayed in 4 digit number

to next page

from Previous Page

Checking item

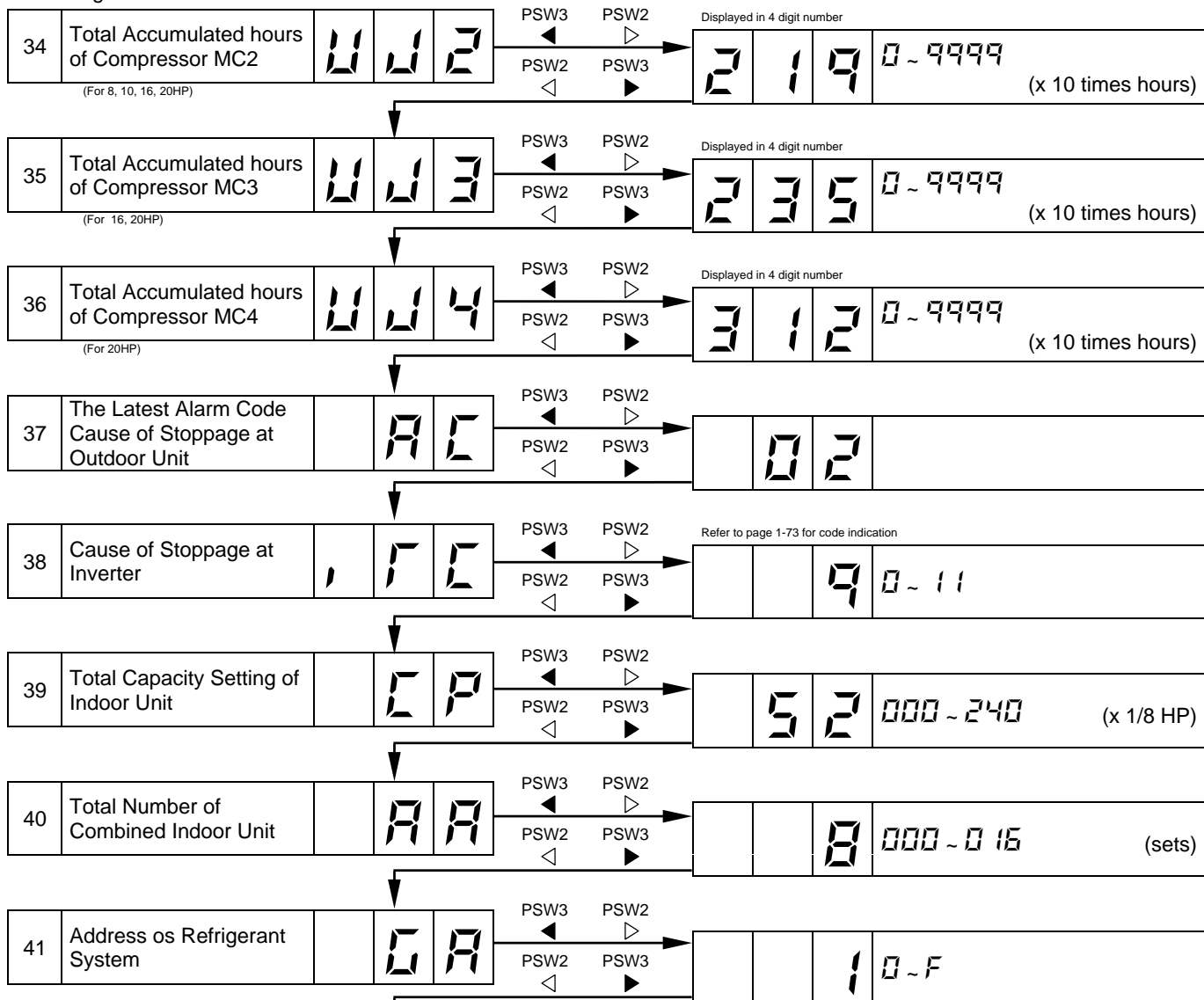

Return to START "5C"

■ RUNNING CURRENT OF COMPRESSOR

- Inverter Primary Current
The inverter primary current is estimated from the running current of the compressor MC1 indicated on 7-segments, as the right chart shows.

- Indicated Running Current of Compressor MC2, MC3, MC4

The running current of the compressor MC2, MC3, MC4, is detected by current sensor. (CT2 ~ CT4)

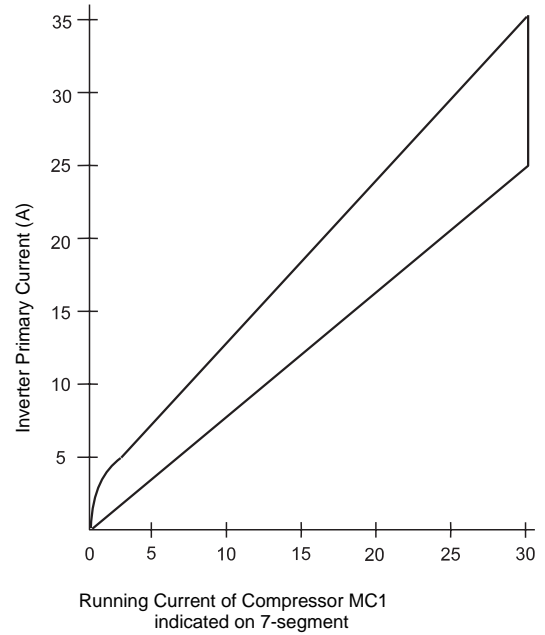

- Cause of Stoppage for Inverter (Content of Check Item "P E")

Code	Cause	Cause of Stoppage for Corresponding Unit	Remark	
			Indication during Retry	Alarm Code
1	Automatic Stoppage of Transistor Module (IPM Error) (Over Current, Decrease Voltage, Increase Temperature)	17	P 17	53
2	Instantaneous Over Current	17	P 17	52
4	Electronic Thermal Activation	17	P 17	52
5	Inverter Voltage Decrease	18	P 18	06
6	Excessively High Voltage	18	P 18	06
8	Abnormal Current Sensor	17	P 17	51
9	Instantaneous Power failure Detection	18	-	-
11	Reset of Micro-Computer for Inverter	18	-	-

■ Protection Control Code on 7-Segment Display

1. The protection control indication can be seen on 7-segments when a protection control is activated.
2. The 7segment continues ON while function is working, and goes out when released.
3. When several protection control are activated, code number with higher priority will be indicated (see besides for the priority order).

- Higher priority is given to protection control related to frequency control than the other.

<Priority Order>

- Pressure Ratio Control
- High-Pressure Rise Protection
- Current Protection
- Discharge Gas Temperature Rise Protection
- Low-Pressure Fall Protection
- Reversing Valve Switching Control (For 16, 20HP)
- High-Pressure Fall Protection
- Oil Return Control

- In relation to retry control, the latest retrial will be indicated unless a protection control related to frequency control is indicated.

Code	Protection Control
P 0 1	Pressure Ratio Control (*)
P 0 2	High-Pressure Rise Protection (*)
P 0 3	Current Protection (*)
P 0 5	Discharge Gas Temperature Rise Protection (*)
P 0 6	Low-Pressure Fall Protection
P 0 7	4-Way Valve Switching Control (For 16, 20HP)
P 0 8	Oil Return Control
P 0 9	High-Pressure Fall Protection

Code	Protection Control
P 1 1	Pressure Ratio Falling Retry
P 1 2	Low-Pressure Rising Retry
P 1 3	High-Pressure Rising Retry
P 1 4	Over Current Retry of Constant Compressor
P 1 5	Vacuum/Discharge Gas Temperature Rising Retry
P 1 6	Discharge Gas SUPERHEAT Falling Retry
P 1 7	Inverter Trip Retry
P 1 8	Voltage Falling/Excessive Voltage Retry

In the case that restricted control is activated, c is indicated instead of 0 (*mark)

- Retry indication continues for 30 minutes unless a protection control is indicated.
- Retry indication disappears if the stop signal comes from all rooms.

Note: The protection control code being indicated on 7-segment display is changed to an alarm code when the abnormal operation occurs. Also, the same alarm code is indicated on the remote control switch.

■ ACTIVATING CONDITION OF PROTECTION CONTROL CODE

For following the conditions as the temperature change, etc., the control of frequency, etc. is performed to prevent the abnormal conditions by the protection control.

The activating conditions of protection control are shown in the table below

Code	Protection Control	Activating Condition	Remarks
P01	Pressure Ratio Control	Compression Ratio $\geq 9 \rightarrow$ Frequency Decrease (Pd/(Ps+1.3)) $\leq 2.2 \rightarrow$ Frequency Increase	Ps: Suction Pressure of Compressor
P02	High-Pressure Rise Protection	Pd ≥ 2.35 MPa (23.5kgf/cm ² G) \rightarrow Frequency Decrease	Pd: Discharge Pressure of Compressor
P03	Current Protection	Inverter Output Current ≥ 14 A \rightarrow Frequency Decrease	-
P05	Discharge Gas Temperature Rise Protection	Temperature at the top of compressor is high \rightarrow Frequency Increase (Maximum temperature is different depending on the frequency.)	-
P06	Low-Pressure Fall Protection	Low-Pressure Is Excessively Low \rightarrow Frequency Increase (Minimum pressure is different depending on the ambient temperature.)	-
P07	4-Way Valve Switching Control (For 16, 20HP)	When Switching, $\Delta P < 0.5$ MPa (5kgf/cm ² G) \rightarrow Frequency Increase $\Delta P < 1.3$ MPa (13kgf/cm ² G) \rightarrow Frequency Decrease	$\Delta P = P_d - P_s$
P08	Oil Return Control	Frequency less than 40Hz is maintained for more than 1 hour \rightarrow Frequency ≥ 40 Hz	-
P09	High-Pressure Fall Protection	Pd ≤ 0.69 MPa (7.0kgf/cm ² G) \rightarrow Frequency Increase (When Cooling Operation) Pd ≤ 1.52 MPa (15.5kgf/cm ² G) \rightarrow Frequency Increase (When Heating Operation)	Pd: Discharge Pressure of Compressor
P11	Pressure Ratio Falling Retry	Compression Ratio (Pd/(Ps+1.3)) < 1.8	When activating 3 times in an hour, "43" alarm is indicated.
P12	Low-Pressure Rising Retry	Ps > 0.9 MPa (9kgf/cm ² G)	When activating 3 times in an hour, "44" alarm is indicated.
P13	High-Pressure Rising Retry	Ps > 2.7 MPa (27kgf/cm ² G) (In case of 20 ~ 30Hz: Pd > 2.5 MPa (25kgf/cm ² G))	When activating 3 times in an hour, "45" alarm is indicated.
P14	Overcurrent Retry of Constant Compressor	Current \geq Maximum Value($\clubsuit 1$), or Current < 0.9 A	When activating 3 times in an hour, "39" alarm is indicated.
P15	Vacuum/Discharge Gas Temperature Rising Retry	In Case of Ps > 0.02 MPa (0.2kgf/cm ² G) over 12 minutes, Discharge Gas Temperature $\geq 132^\circ\text{C}$ over 10 minutes or Discharge Gas Temperature $\geq 140^\circ\text{C}$ over 5 seconds	When activating 3 times in 30 minutes, "47"(Ps) or "08" (Discharge Gas) alarm is indicated.
P16	Discharge Gas SUPERHEAT Falling Retry	Discharge Gas SUPERHEAT less than 10 deg. is maintained for an hour.	When activating 2 times in 2 hours, "07" alarm is indicated.
P17	Inverter Trip Retry	Automatic Stoppage of Transistor Module, Activation of Electronic Thermal or Abnormal Current Sensor	When activating 3 times in 30 minutes, "51", "52" and "53" alarm is indicated.
P18	Voltage Falling / Excessive Voltage Retry	Insufficient/Excessive Voltage at Inverter Circuit or CB Condenser Part	When activating 3 times in 30 minutes, "06" alarm is indicated.

1. During protection control (except during alarm stoppage), the protection control code is indicated.
2. The protection control code is indicated during protection control and turns off when canceling the protection control.
3. After retry control, the condition of monitoring is continued for 30 minutes.

Note: The maximum value ($\clubsuit 1$) is as follows:

Model	380-415V, 50 Hz
8 HP	12.1 A
10 HP	15.0 A
16 HP	17.8 A
20 HP	17.8 A

1.2.5 FUNCTION OF RSW, DSW AND LEDS

■ Printed Circuit Board in Indoor Unit.

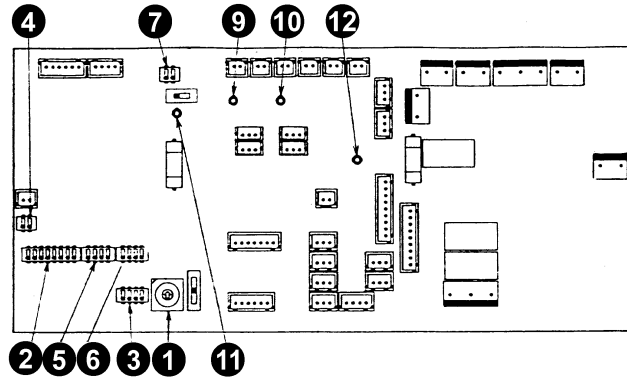

■ Dip Switch and LED Functions on Indoor Unit Printed Circuit Board

Part Name	Contents of Functions
① RSW	Setting of Indoor Unit Number
② DSW2	Setting of Optional Functions A. Self-Diagnosis B. Remote ON/OFF Control C. Automatic Restart after Short Power Failure D. Remote Sensor Control
③ DSW3	Setting of Indoor Unit Capacity Code
④ DSW4	Setting of Capacity Adjustment
⑤ DSW5	Setting of Refrigerant Cycle No. Setting
⑥ DSW6	Setting of Unit Code
⑦ DSW7	Setting of Fuse Recover
⑨ LED1 (Red)	This LED1 indicates the transmission state between the indoor unit and remote control switch. Normal Condition: Flickering Abnormal Condition: Activated or Deactivated
⑩ LED2 (Green)	This LED2 indicates the transmission state between the indoor unit and central station. (When disconnected: Deactivated) Normal Condition: Flickering Abnormal Condition: Activated or Deactivated
⑪ LED3 (Yellow)	This LED3 indicates the transmission state between the indoor unit and outdoor unit. Normal Condition: Flickering one time/some seconds Abnormal Condition: Activated or Deactivated more than 30 seconds or Flickering (30 times/1 second)
⑫ LED4 (Red)	This LED4 indicates the power supply (5V) for micro-computer. Normal Condition: Activated Abnormal Condition: Deactivated

■ Printed Circuit Board in Outdoor Unit

- Arrangement
Inside of Main Electrical Box

RAS-5FSG, RAS-5FS3

Before Manufacturing # U4MV0196

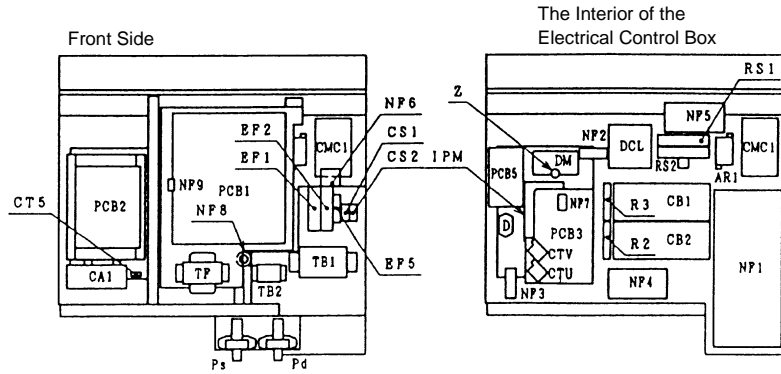

After Manufacturing # U4MV0197

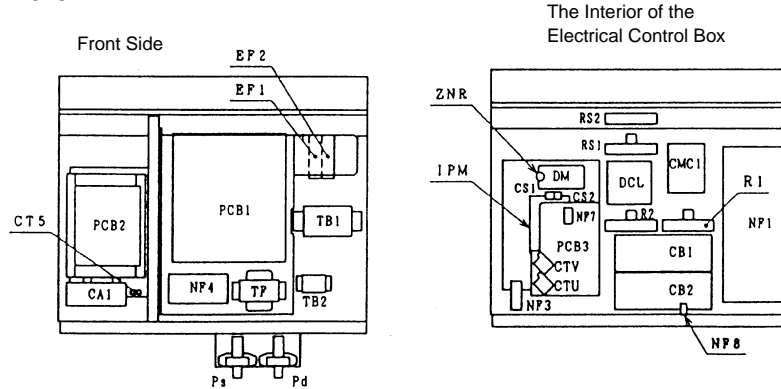

RAS-8-20FSG, RAS-8-20FS3

Before Manufacturing # U4NG1001

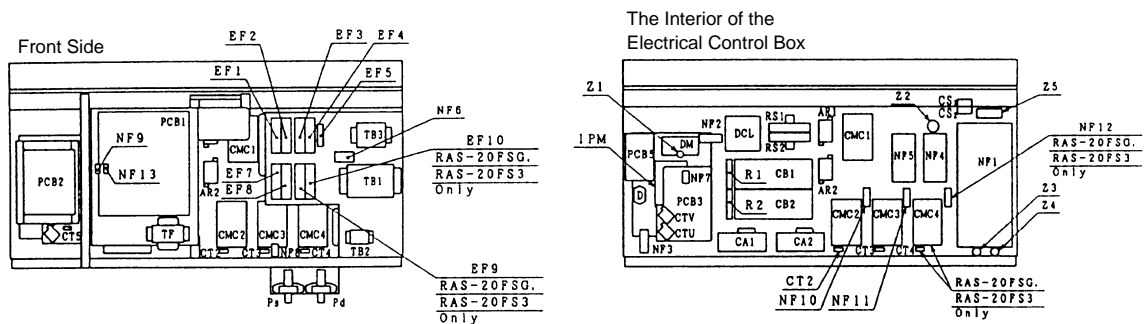

EF7, EF8, CT3, CMC3, NF11: Only for RAS-16FSG, RAS-16FS3, RAS-20FSG and RAS-20FS3

After Manufacturing # U4NG1002

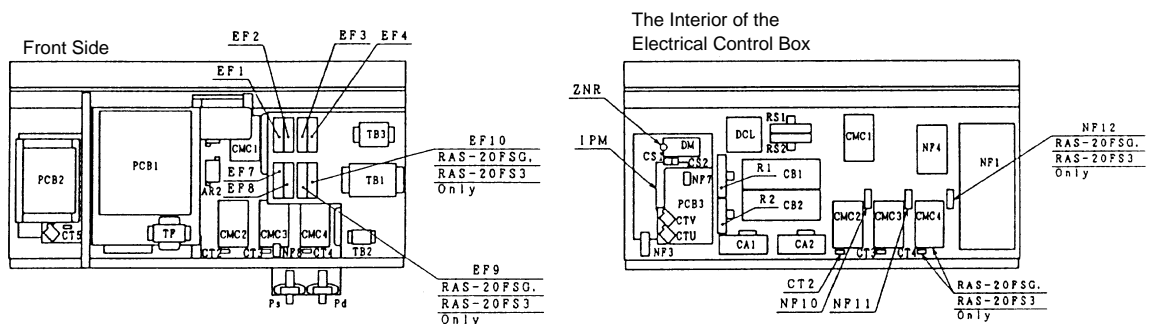

EF7, EF8, CT3, CMC3, NF11: Only for RAS-16FSG, RAS-16FS3, RAS-20FSG and RAS-20FS3

▪ Purpose

Symbol	PCB	Purpose
PCB1	for Control	1. Transmitting between Indoor Unit and Outdoor Unit 2. Processing for Sensor Input 3. Processing for Dip Switch Input 4. Operation Control for Above items 1 to 3. Compressor Operation Control, Bypass Valve Control, Fan Control and Overcurrent Control 5. 7-Segment Indication 6. Processing of Safety Device Input 7. Processing of Relay Output 8. Reverse Phase Detection for Power Source
PCB2	for Fan	Fan Speed Control
PCB3	for Inverter	1. Inverter power part is driven by instruction of PCB1 and compressor is driven. 2. Overcurrent Control 3. Protection Control for Inverter Part
PCB5	for "SNUBBER"	1. Restraining of Surge Voltage added to Transistor Module (IPM) 2. Absorbing for Switching Noise of Transistor Module (IPM)

a. Control Printed Circuit Board: PCB1

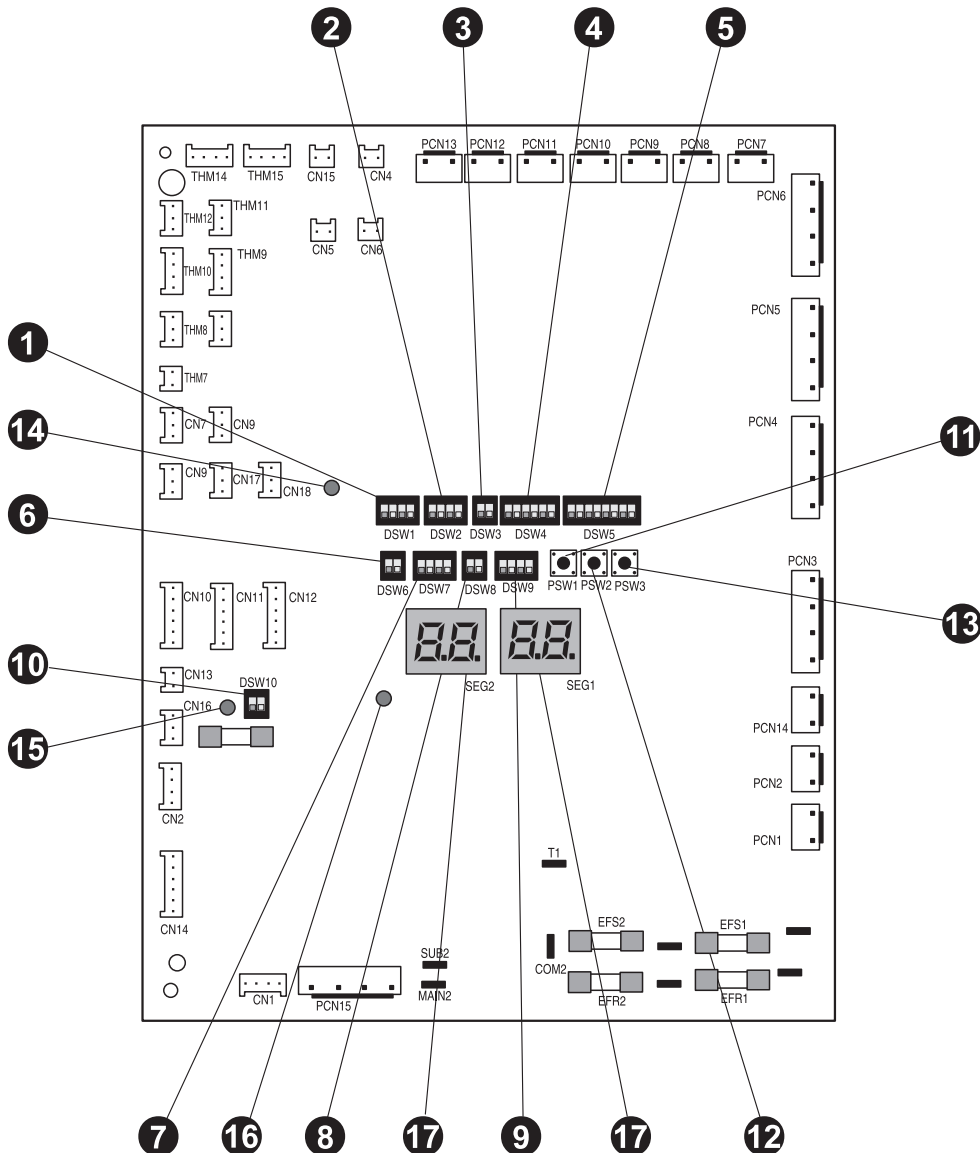

■ Dip Switches and LED Functions on Outdoor Unit Printed Circuit Boards

Name of Internal Circuit Board	Part Name	Contents of Functions
Controlling Board: PCB1	① DSW1	Setting of Outdoor Unit Number
	② DSW2	Setting of Capacity Code Outdoor unit capacity is set according to nominal capacity (HP).
	③ DSW3	Setting of Height Difference The height difference between outdoor and indoor units is set.
	④ DSW4	A. Test Running for Cooling or Heating An outdoor unit can be run for testing. When testing has been finished, reset the function. B. Forced Stoppage of Compressor When performing test running or inspection, compressors can be forcedly stopped to ensure safety.
	⑤ DSW5 (Optional Function)	A. Changeover of Defrosting Condition The defrosting operation for normal areas or cold areas can be changed over. B. Power Supply Changeover Switch #7 pin 380V: OFF, 415V: ON
	⑥ DSW6	Setting of Piping Length The total piping length between the outdoor unit and indoor unit is set.
	⑦ DSW7	Setting of Emergency Operation
	⑧ DSW8	Test Operation and Service Setting II No setting is required.
	⑨ DSW9	Optional Function 2
	⑩ DSW10	Transmitting Setting
	⑪ PSW1	Manual Defrosting Switch The defrosting operation is manually available under the forced defrosting area.
	⑫ PSW2	Check Switches When checking units, checking items can be selected by these switches.
	⑬ PSW3	
	⑭ LED1 (Red)	Power Source for PCB1 Normal Condition: Activated Abnormal Condition: Deactivated
	⑮ LED2 (Green)	This LED2 indicates the transmission state between the PCB1 and PCB3 Normal Condition: Flickering Abnormal Condition: Activated or Deactivated
	⑯ LED3 (Yellow)	This LED3 indicates the transmission state between the indoor unit and outdoor unit. Normal Condition: Flickering Abnormal Condition: Activated or Deactivated
	⑰ SGE1 SGE2	These indicate the following: "alarm", "protective safety device has tripped" or "checking items".

b. Inverter Printed Circuit Board: PCB3

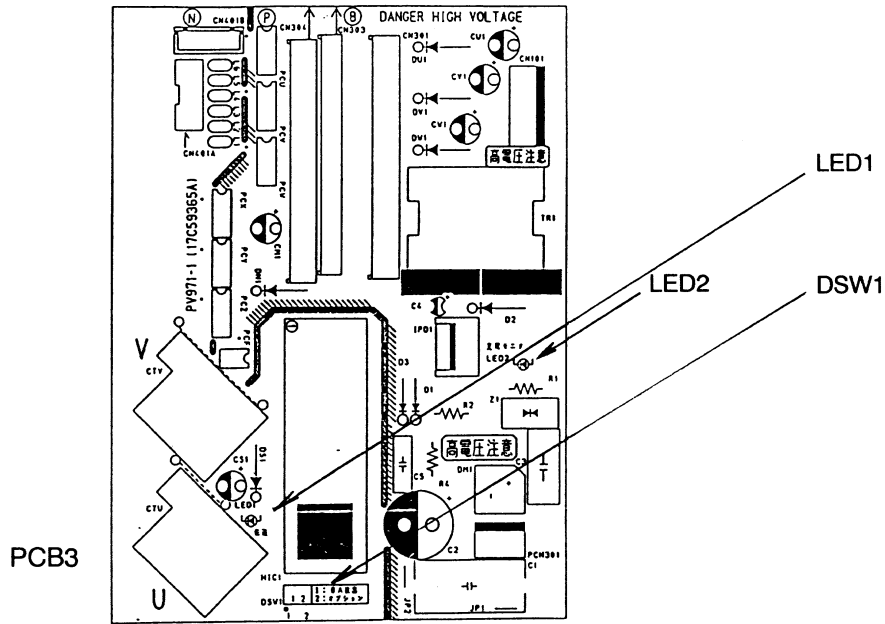

*Dip Switch and LED Functions on Outdoor Unit Inverter Printed Circuit Board

Switch Name	Function
DSW1	
	Normal: No.1 and No.2 of DSW1 are OFF. Emergency Operation or Troubleshooting: No.1 of DSW1 is ON No.2 of DSW1 is OFF The above setting aims not to trip even if the CT detects 0A.

Name of Printed Circuit Board	Function
LED1 (Red)	This indicates the state of transmission. Flickering: Normal Transmission Activated or Deactivated: Abnormality in Transmission Circuit
* LED2 (Red)	This indicates the voltage between both terminal of capacitor CB1 and CB2 for inverter part. Activated: The voltage between both terminals of capacitor, CB is 50V ± 20V or greater. Deactivated: The voltage between both terminals of capacitor, CB is 50V ± 20V or smaller.

*: Applied to the following products;
 RAS-5FSG/FS3 (After Manufacturing # U4MV0197)
 RAS-8-20FSG/FS3 (After Manufacturing # U4NG1002)

c. "SNUBBER" Board: PCB5

This PCB is applied to the following products only;
 RAS-5FSG/FS3 (Before Manufacturing # U4MV0196)
 RAS-8~20FSG/FS3 (Before Manufacturing # U4NG1001)
 LED3

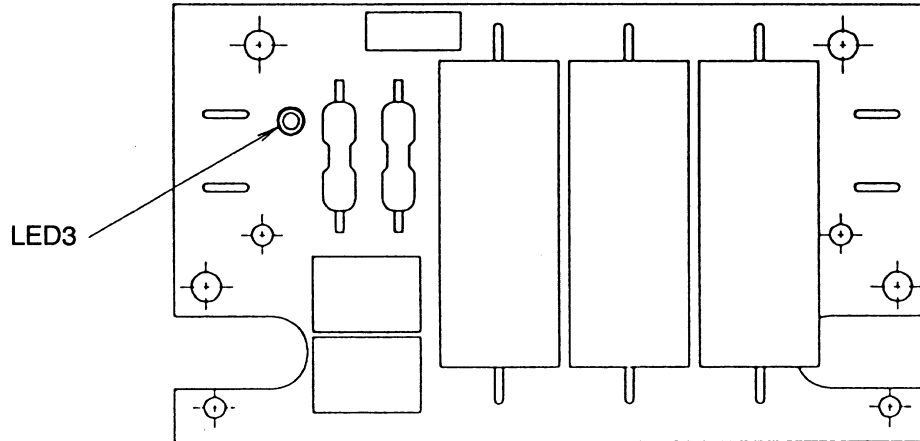

* LED Function on Outdoor Unit Printed Circuit Board

Name of Printed Circuit Board	Function
LED3 (Red)	This indicates the voltage between both terminal of capacitor CB1 and CB2 for inverter part. Activated: The voltage between both terminals of capacitor, CB is 50V \pm 20V or greater. Deactivated: The voltage between both terminals of capacitor, CB is 50V \pm 20V or smaller.

1.3 PROCEDURE OF CHECKING EACH MAIN PARTS

1.3.1 SELF CHECKING OF PCBs USING REMOTE CONTROL SWITCH

Following troubleshooting procedure is utilized for function test of PCB's in the Indoor Unit and Outdoor Unit

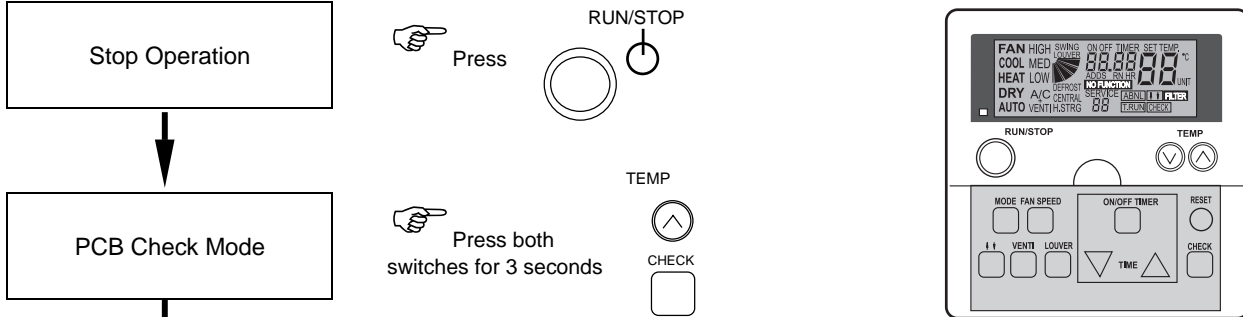

(ex.) indication of Unit No. "0"

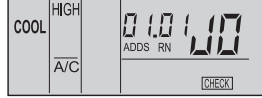

After 7 seconds

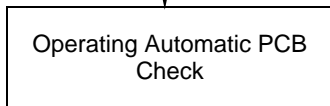

Result After Approx. 5 sec. (Max 30 Sec. in case of transmission failure between Indoor Unit and Outdoor Unit) Max. 3 types of abnormalities indicated.

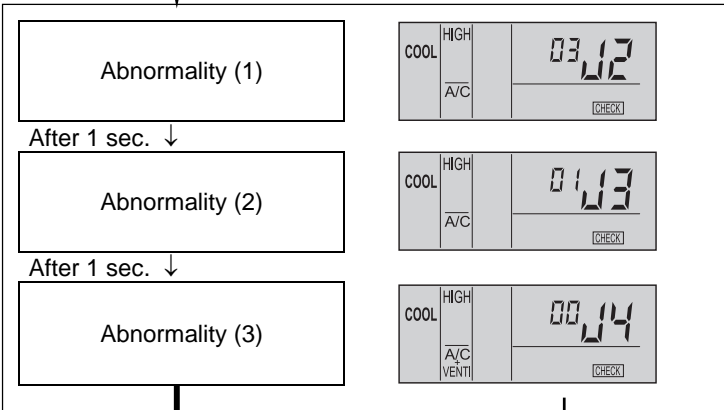

After 1 second

To next page

Indication	Contents	
00	Normal	
	Abnormality (Open-circuit, Short-circuit, etc.) in circuit for	
01	Intake Air Temp. Thermistor	Indoor Unit PCB
02	Discharge Air. Temp. Thermistor	
03	Liquid Pipe Temp. Thermistor	
04	Remote Thermistor abnormality	
05	Gas Pipe Temp. Thermistor	
06	Remote Sensor	
08	Transmission of Central Station	
0A	EEPROM	
0b	Zero Cross Input Failure	
EE	Transmission of indoor during this checking operation	
	The checking operation	
07	Transmission of Outdoor Unit	Outdoor Unit PCB
F4	ITO Input Failure	
F5	PSH Input failure	
F6	Protection Signal Detection Circuit	
F7	Phase Detection	
F8	Transmission of Inverter	
F9	High Pressure Sensor	
Fb	Comp. Discharge Gas Temp. Thermistor	
Fc	Low pressure Sensor	
Fd	Heat Exchanger Evaporation Temp. Thermistor	
FF	Ambient Air Temp. Thermistor	

For performing the above checking in the case that the wireless remote control switch is used with the built-in receiver part of the wall type indoor, perform the following procedures:

1. Turn OFF the power supply.
2. Disconnect the connector (CN25) on PWB(M).
3. Connect PC-2H2 to the connectors CN12 or CN13.
4. Turn ON the power supply

After completion of checking, turn OFF the power supply again and make connectors as before checking.

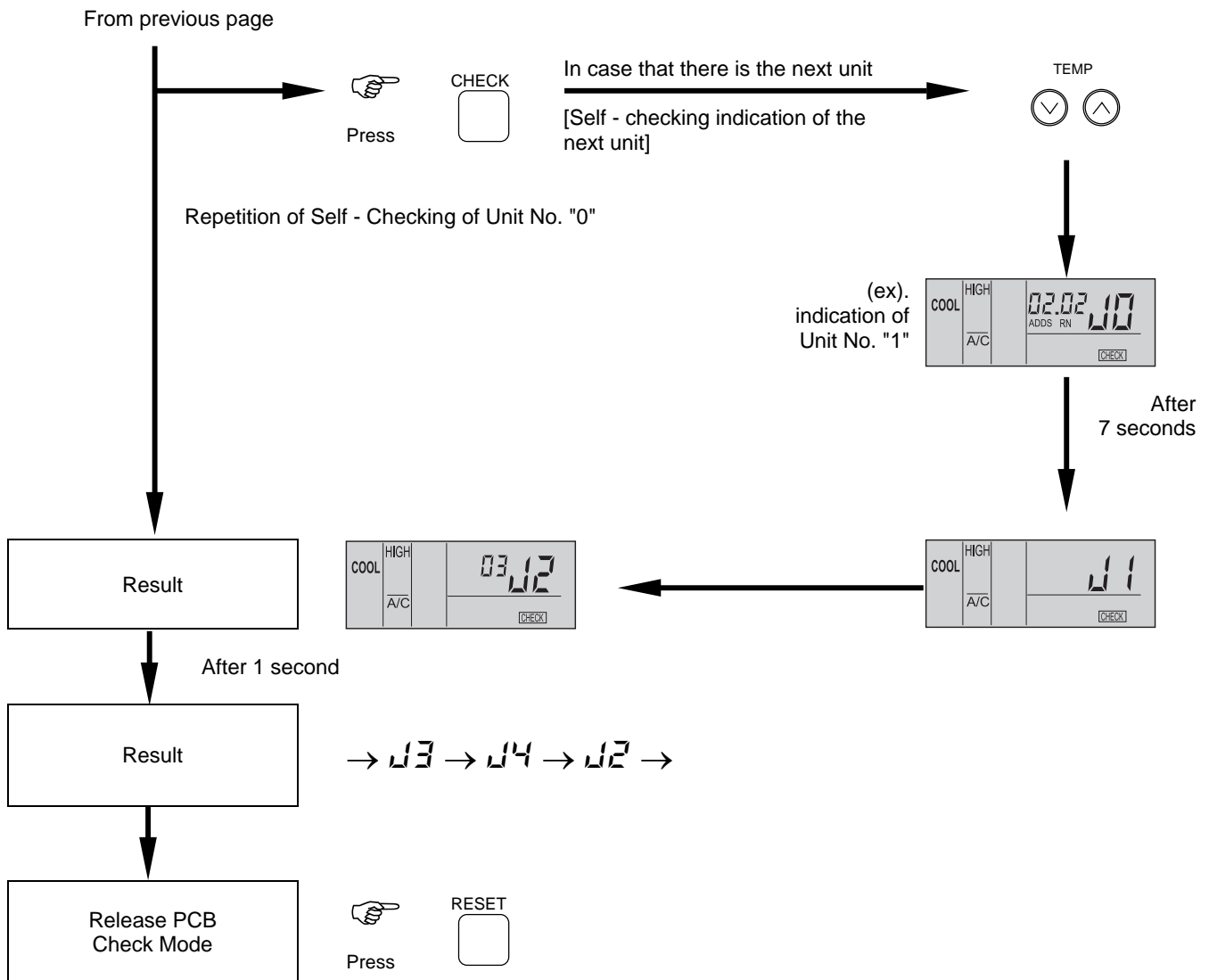
**Note:**

- 

If this indication is continued and "1" is not shown, this indicated that each one of indoor unit is not connected to the remote control switch. Check the wiring between the remote control switch and indoor unit.
- In this troubleshooting procedure, checking of the following part of the PCB's is not available.
 PCB in Indoor Unit: Relay Circuit, Dip Switch, Option Circuit
 PCB in Outdoor Unit: Relay Circuit, Dip Switch, Option Circuit
- If no result is given using this troubleshooting procedure (J1), there is a possibility of abnormal transmission of the central station (short-circuit: TL - TG).
- In the case that this troubleshooting is performed in the system using the central station, indication of the central station may change during this procedure. However, this is not abnormal.
- After this troubleshooting, the memory of abnormality occurrence times described before will be deleted.

1.3.2 SELF-CHECKING OF REMOTE CONTROL SWITCH

Cases where CHECK switch is utilized.

1. If the remote control switch reads malfunction
2. For regular maintenance check.

1 Turn ON the power source

2 Simultaneously depress the following 3 switches. (During operation, they can be depressed.)



3 The LCD indication changes as shown in the right figure

4 After the LCD indication changes as shown in the right figure, the RUN indicator flickers twice.



5 The LCD indication changes as shown below. Depress all the switches (13 switches) one by one. Every time the switch is depressed the number of the indication of (A) part in the figure below increases one by one.

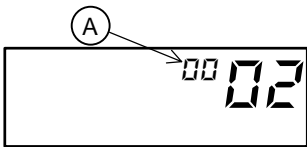

Notes: - Any order of depressing switches is available.
- Depressing two or more switches simultaneously is invalid and not counted

6 The LCD indication changes as shown below. The remote control switch automatically starts to check the transmission circuit.

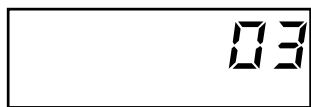

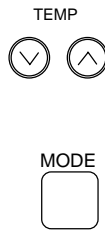

To the next page

Only for cancellation of EEPROM, depress the following 3 switches simultaneously during changing LCD indication.

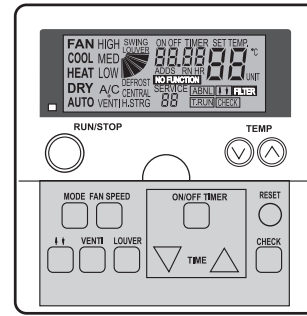

To 11

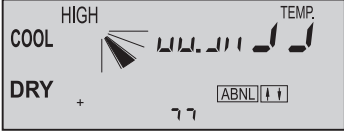
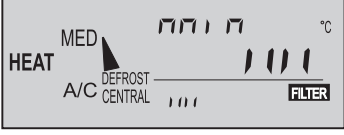

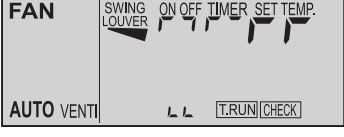
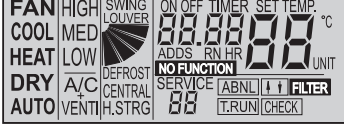
No.	LCD Indication	Indicating Period (sec.)
1		For 1 second
2		For 1 second
3		For 1 second
4		For 1 second
5		For 3 seconds

Unless all the switches are depressed, the checking do not proceed to the next item

In case that transmission circuit is abnormal, the LCD indication remains as the left figure and the checking do not proceed to the next item.

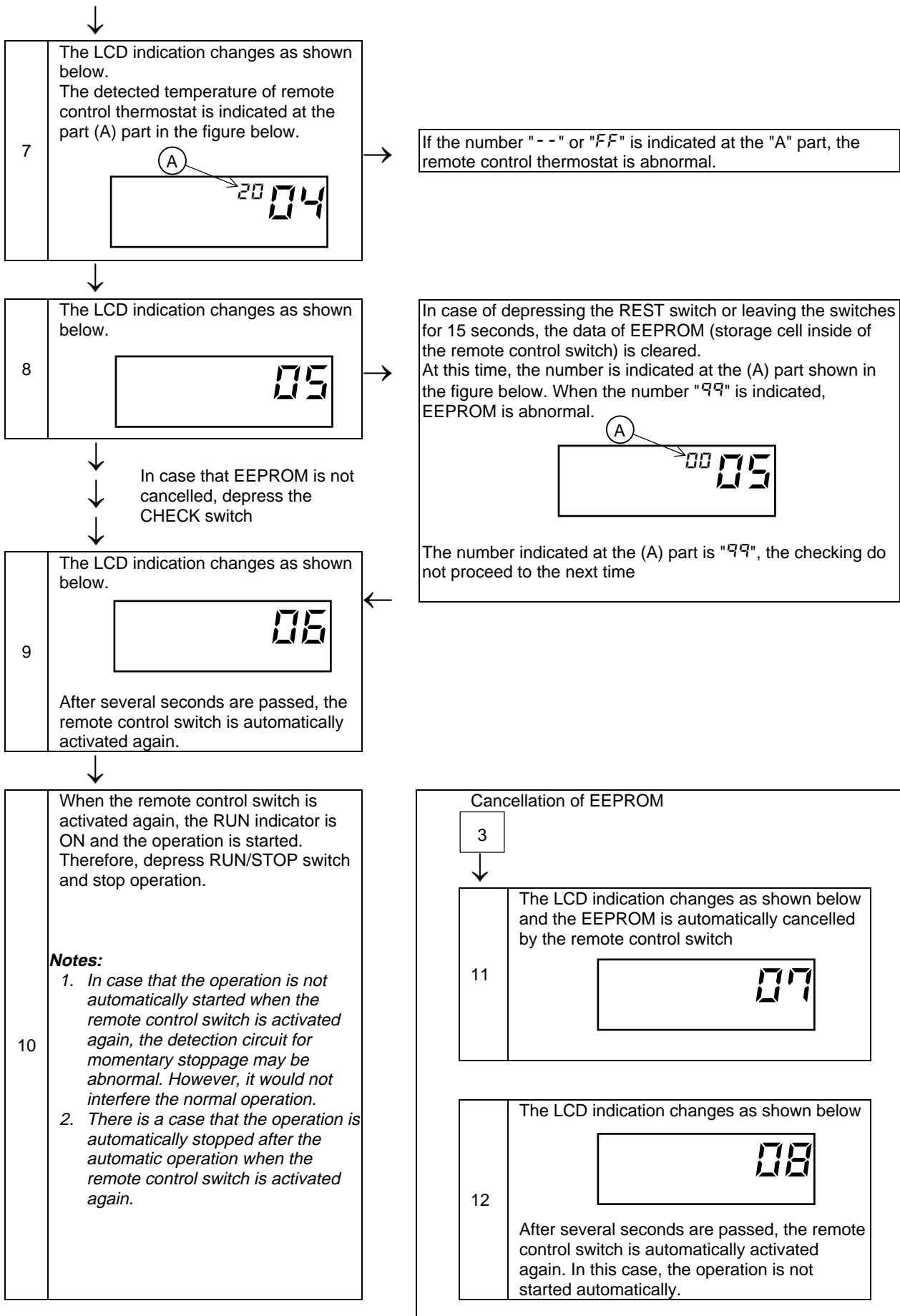

1.3.3 SELF-CHECKING OF INDOOR UNIT PCB

■ Self-Checking by Relays on Indoor Unit PCB

- To Check Abnormality on Indoor Unit PCB due to Malfunction
- To check Abnormality on Indoor Unit PCB Based on Results of Checking by CHECK switch on the remote control switch and Self-Checking Function

■ Procedure

Refer to page 1-76 for location and function of DSW and LED.

- ① Turn OFF the main power switch.
- ② Disconnect connectors CN5 and CN8, and set dip switch DSW2 as shown below.

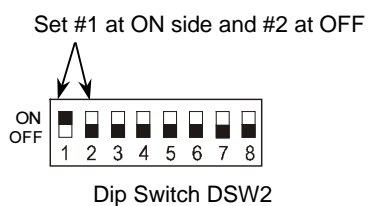

Note: Before turning ON the power, see checking procedure mentioned in next page

- ③ Turn ON the main power switch.
Check Mode starts. (See next page.)

A Analog Test
B Relay Test
- ④ After completion of self-checking, turn OFF the power and reset the dip switch as before.

■ Self-Checking Procedures in Check Mode

For: RCI-FSGE, RCD-FSG, RPI-FSG(E), RPC-FSGE, RPF(I)-FSG

Check Item	State of Mode	Confirmation Method
(A) Initialize Exp. Valve and Auto Louver ↓	Exp. Valve fully open → fully closed Auto Louver is horizontally stopped.	
(B) Analog Test ↓	If each thermistor for intake air, discharge air and freeze protection is normal, proceed to the next step.	If FAN operation is available, it is normal.
(C) Each Relay Test ↓ Repeatedly Perform		Check ON/OFF sound of relays and LED lamp.
Termination	Turn OFF and reset all dip switches as they were.	

For: RPK-FSGM

Check Item	State of Mode	Confirmation Method
(A) Initialize Exp. Valve and Auto Louver ↓	Exp. Valve fully open → fully closed Auto Louver is horizontally stopped.	
(B) Analog Test ↓	If each thermistor for intake air, discharge air and freeze protection is normal, proceed to the next step.	
(C) Each Relay Test ↓ Repeatedly Perform		Check ON/OFF sound of relays and LED lamp.
Termination	Turn OFF and reset all dip switches as they were.	

1.3.4 SELF - CHECKING OF 7 - DAY TIMER (PSC-3T)

This procedure is utilized for regular maintenance check, and if the 7-day timer is malfunction.

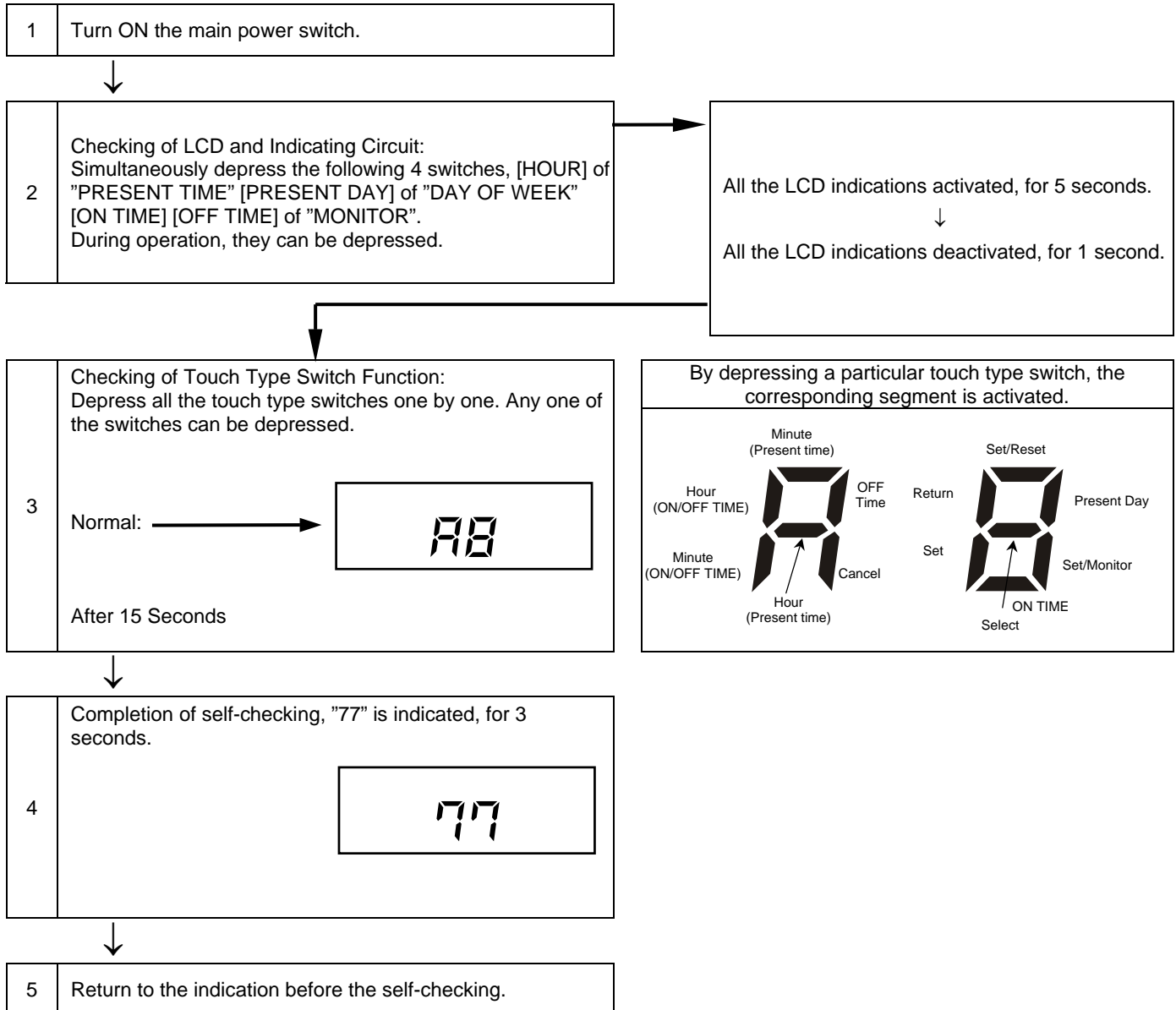

1.3.5 SELF - CHECKING OF CENTRAL STATION (PSC-3S1)

This procedure is utilized for regular maintenance check, and if the central station is malfunction.

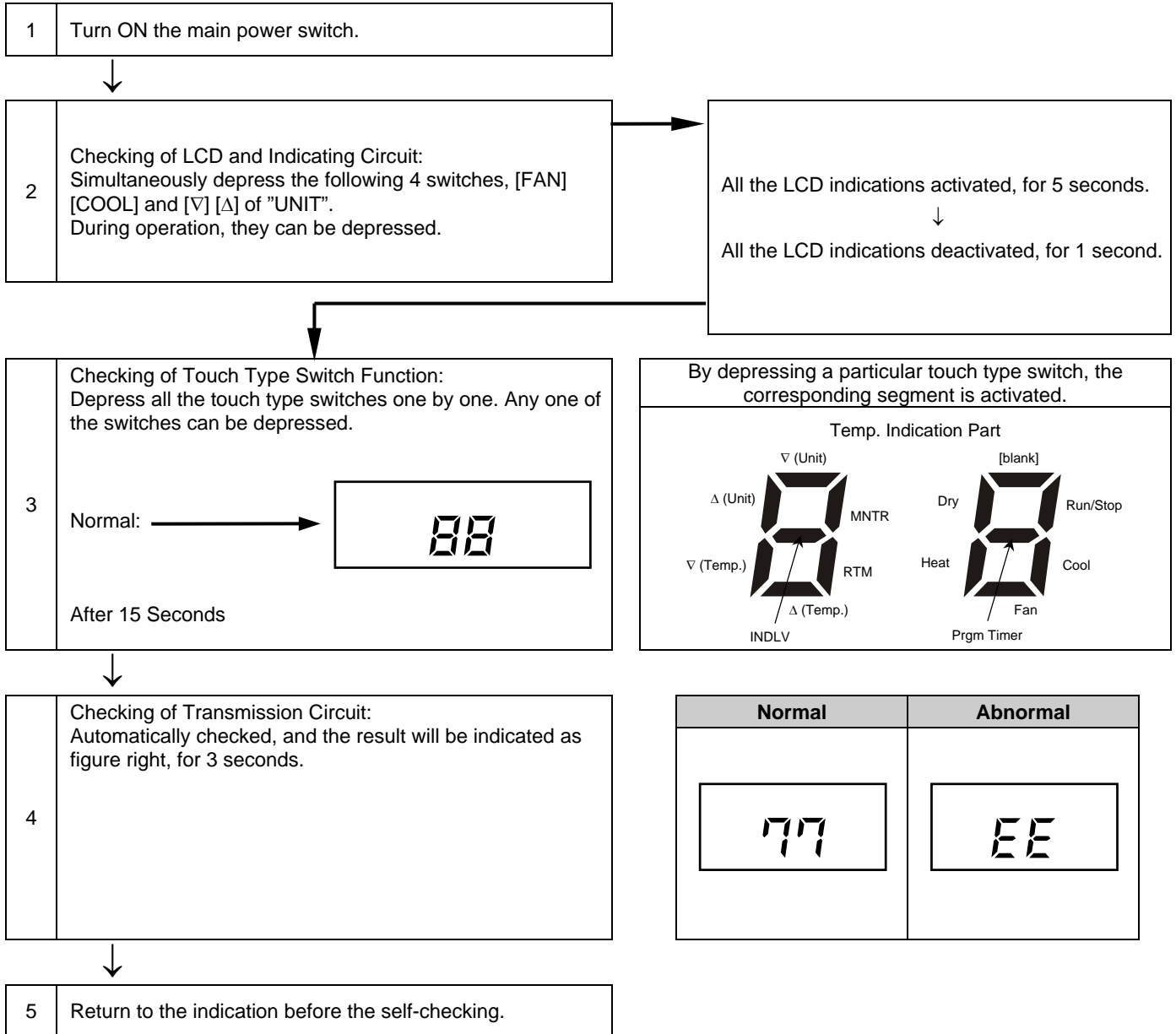

1.3.6 PROCEDURE OF CHECKING OTHER MAIN PARTS

■ High Voltage Discharge Work for Replacing Parts

⚠ DANGER:

Perform this high voltage discharge work to avoid an electric shock.

Procedure:

- Turn OFF the main switches and wait for three minutes. Check to ensure that no high voltage exists. If "A" is ON after start-up and "A" is OFF after turning OFF power source, the voltage will decrease lower than DC50V.
- Connect connecting wires to an electrical brazer.
- Connect the wires to terminals, P and N on transistor module. →Discharging is started, resulting in hot brazer. Pay attention not to short-circuit between terminal P and N .

Manufacturing #	"A"	Case
Before U4NG1001	LED3 on PCB5	1
After U4NG1002	LED2 on PCB3	2

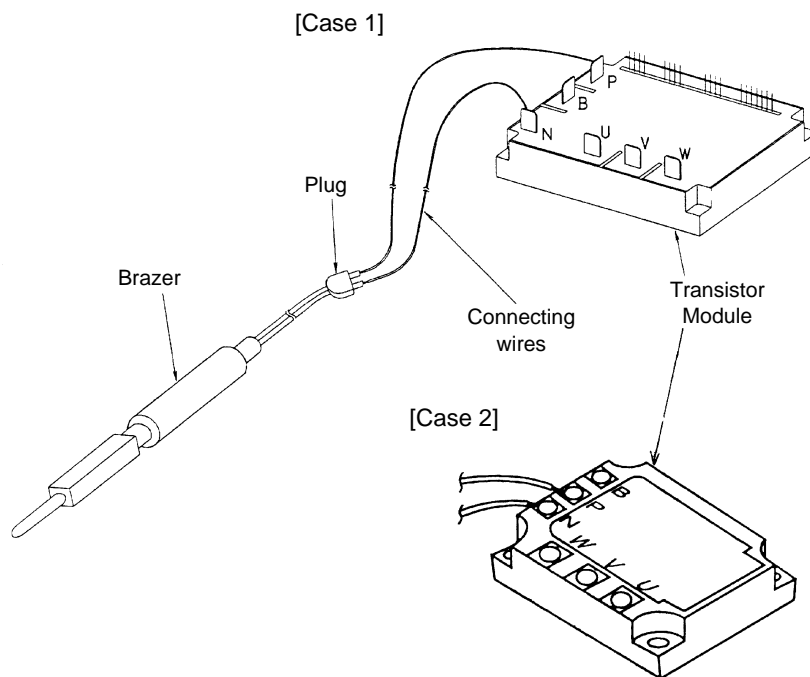

- Wait for 2 or 3 minutes and measure the voltage once again. Check to ensure that no voltage is charged.

■ Checking Procedures Transistor Module

Outer Appearance and Internal Circuit of Transistor Module

[Case1]

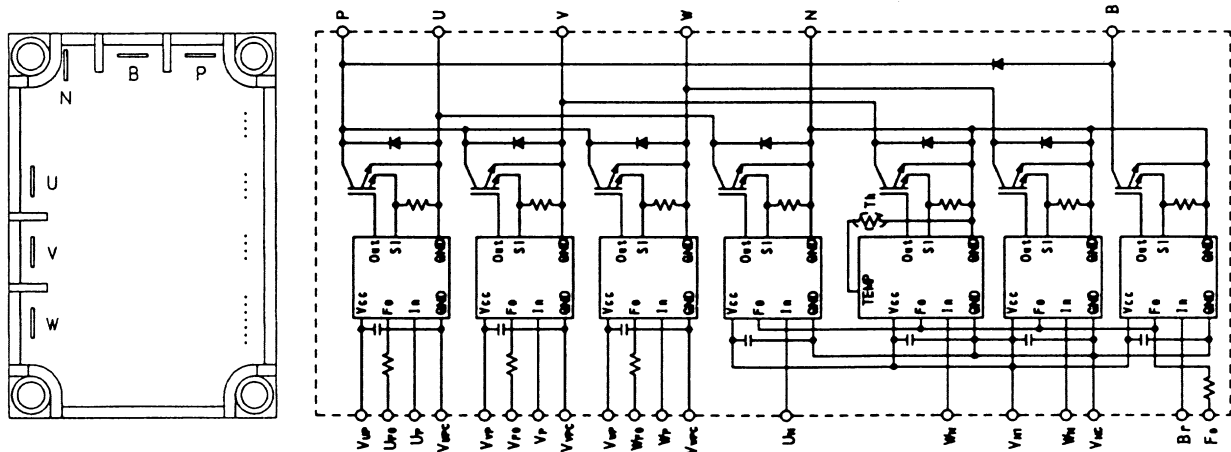

[Case2]

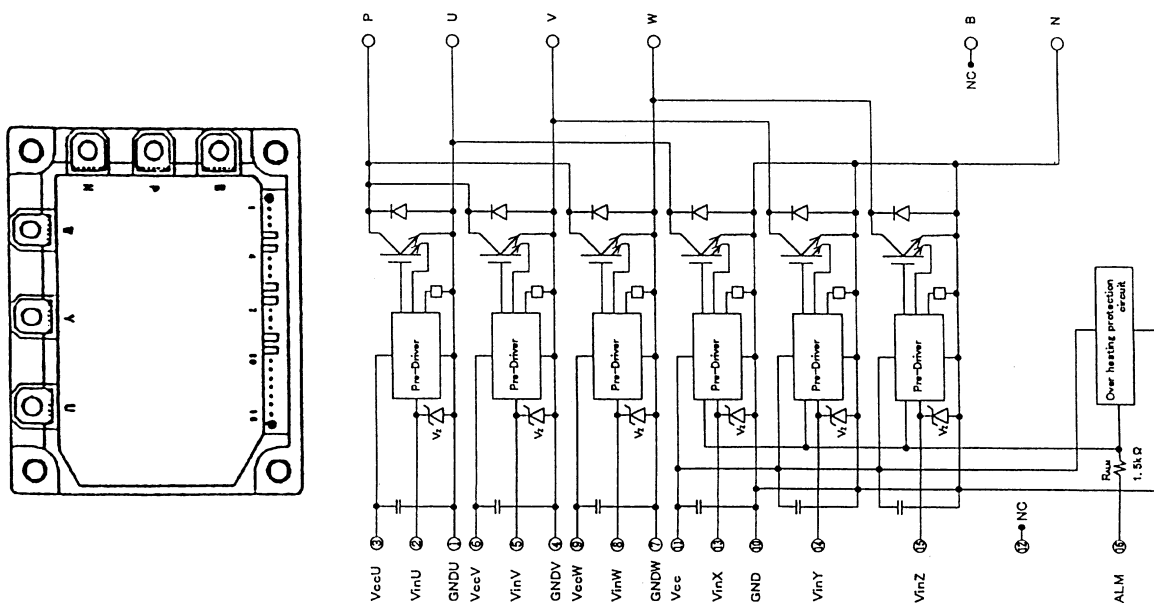

Remove all the terminals of the transistor module before check.

If items (a) to (e) are performed and the results are satisfactory, the transistor module is normal.

Measure it under 1 k Ω range of a tester. Do not use a digital tester.

- By touching the + side of the tester to the P terminal of transistor module and the - side of tester to U, V and W of transistor module, measure the resistance. If all the resistances are from 1 to 5 k Ω , it is normal.
- By touching the - side of the tester to the P terminal of transistor module and the + side of tester to U, V and W of transistor module, measure the resistance. If all the resistances are greater than 100 k Ω , it is normal.

a)

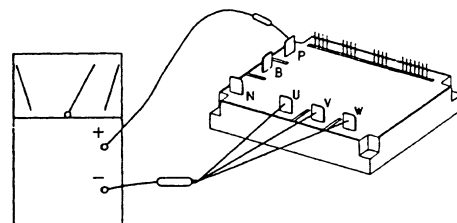

b)

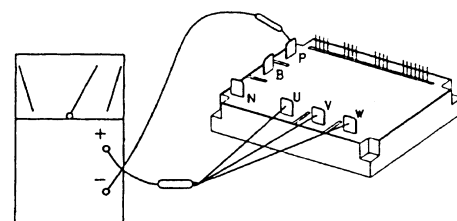

- c. By touching the - side of the tester to the N terminal of transistor module and the + side of tester to U, V and W of transistor module, measure the resistance. If all the resistances are from 1 to 5 k Ω , it is normal.
- e. By touching the + side of the tester to the N terminal of transistor module and the - side of tester to U, V and W of transistor module, measure the resistance. If all the resistances are greater than 100 k Ω , it is normal.

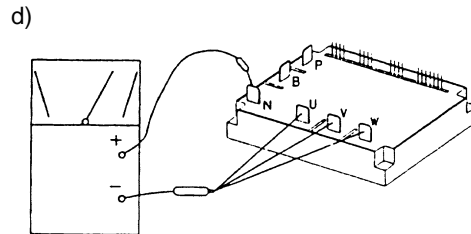
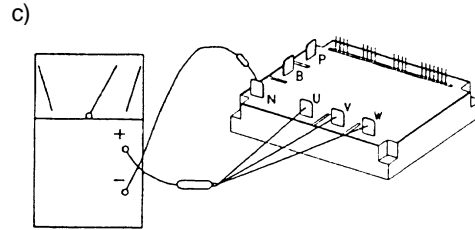

■ Checking Procedures on Diode Module

Outer Appearance and Internal Circuit of Diode Module

[Case1]

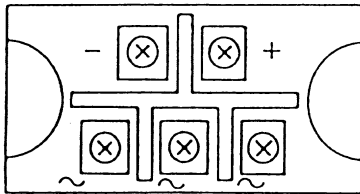

[Case2]

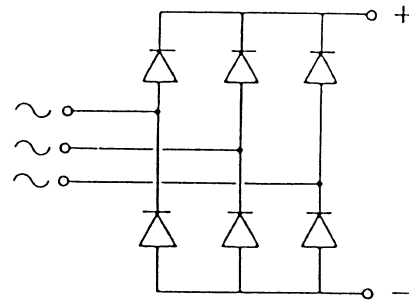
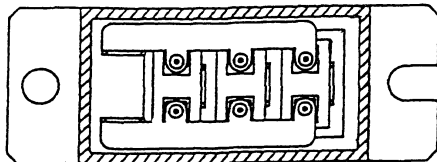

If items (a) to (d) are performed and the results are satisfactory, the diode module is normal. Measure it under 1 k Ω range of a tester. Do not use a digital tester.

- a. By touching the + side of the tester to the + terminal of the diode module and the - side of tester to the ~ terminals (3 NOs.) of the diode module, measure the resistance. If all the resistances are from 5 to 50 k Ω , it is normal.

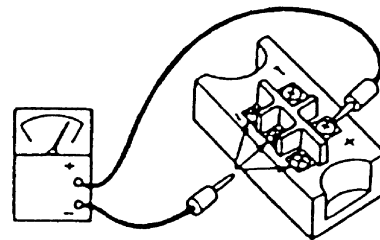

b. By touching the - side of the tester to the + terminal of the diode module and the + side of tester to the ~ terminals (3 Nos.) of the diode module, measure the resistance. If all the resistances are greater than 500 k Ω , it is normal.

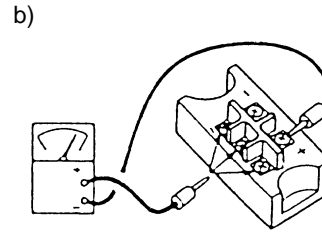

c. By touching the - side of the tester to the - terminal of the diode module and the + side of tester to the ~ terminals (3 Nos.) of the diode module, measure the resistance. If all the resistances are from 5 to 50 k Ω , it is normal.

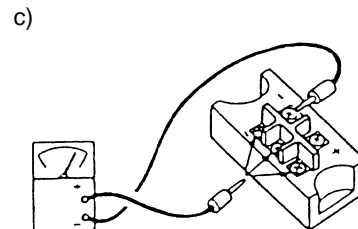

d. By touching the + side of the tester to the - terminal of the diode module and the - side of tester to the ~ terminals (3 Nos.) of the diode module, measure the resistance. If all the resistances are greater than 500 k Ω , it is normal.

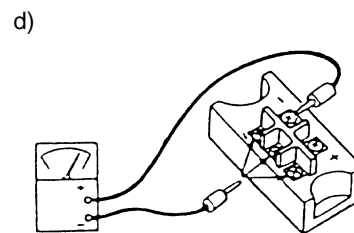

■ Checking Method of Electronic Expansion Valve

	Indoor Unit Electronic Expansion Valve	Outdoor Unit Electronic Expansion Valve
Locked with Fully Closed	Check for the liquid pipe temperature during heating operation. It is abnormal if the temperature does not increase.	It is abnormal if the liquid pipe pressure does not increase during cooling operation.
Locked with Slightly Open	It is abnormal under the following conditions; The temperature of freeze protection thermistor becomes lower than the suction air temperature when the unit under checking is stopped and other units are under cooling operation.	It is abnormal if the liquid pipe pressure does not increase and the outlet temperature of the expansion valve decreases after the cooling operation is started.
Locked with Fully Open		It is abnormal under the following conditions; After heating operation for more than 30 min., the discharge gas temperature of compressor is not 10 °C higher than the condensing temperature and there is no other faults such as excessive charge of refrigerant, etc.

■ Checking of Electrical Coil Parts

Abbreviations Used for Colors	
Black	BLK
Brown	BRN
Red	RED
Yellow	YEL
Green	GRN
Blue	BLU
Grey	GRY
Orange	ORN
White	WHT

Name of Parts	Model	Electrical Wiring Diagram	Wiring No.	Resistance (Ω)
Fan Motor for Indoor Unit: for: RPK-1.0FSGM RPK-1.5FSGM RPK-2.0FSGM RPK-2.3FSGM	EHO2M2P4P30 30W	DC Motor	--	-
Fan Motor for Indoor Unit for: RPF-1.0FSG RPF-1.0FSG	TNO-KPPA 75W		BLK① - ②RED RED② - ③WHT	127.90 102.70 at 20 °C
Fan Motor for Indoor Unit for: RPF-1.5FSG RPF-1.5FSG	TNO-KPPA 35W		BLK① - ②RED RED② - ③WHT	127.90 102.0 at 20 °C
Fan Motor for Indoor Unit for: RPI-0.8FSGE RPI-1.0FSGE RPI-1.5FSGE	45W		BLK① - ②RED RED② - ③BLU BLU③ - ④YEL YEL④ - ⑤GRN GRN⑤ - ⑥GRY RED② - ⑦WHT	58.36 14.87 14.87 18.88 18.88 124.91 at 20 °C
Fan Motor for Indoor Unit for: RPI-2.0FSGE RPI-2.5FSGE	150W		BLK① - ②RED RED② - ③BLU BLU③ - ④GRY GRY④ - ⑤YEL RED② - ⑥WHT	32.55 8.20 3.17 5.12 45.69 at 20 °C

Name of Parts	Model	Electrical Wiring Diagram	Wiring No.	Resistance (Ω)
Fan Motor for Indoor Unit for: RPI-3.0FSGE	180W		BLK① - ②RED RED② - ③BLU BLU③ - ④GRY RED② - ⑤WHT	23.99 7.67 6.16 26.63 at 20 °C
Fan Motor for Indoor Unit for: RPI-4.0FSGE	200W		BLK① - ②RED RED② - ③BLU BLU③ - ④GRY RED② - ⑤WHT	19.65 7.29 5.66 20.71 at 20 °C
Fan Motor for Indoor Unit for: RPI-5.0FSGE	250W			
Fan Motor for Indoor Unit for: RCI-1.0FSGE	5W		BLK① - ②RED RED② - ③BLU BLU③ - ④ORN ORN④ - ⑤YEL RED② - ⑥WHT	167.10 47.30 46.70 58.70 249.00 at 25 °C
Fan Motor for Indoor Unit for: RCI-1.5FSGE	17W			
Fan Motor for Indoor Unit for: RCI-2.0FSGE RCI-2.5FSGE RCI-3.0FSGE	60W		BLK① - ②RED RED② - ③BLU BLU③ - ④ORN ORN④ - ⑤YEL RED② - ⑥WHT	117.10 28.50 40.35 39.60 210.65 at 25 °C
Fan Motor for Indoor Unit for: RCI-4.0FSGE RCI-5.0FSGE	60W		BLK① - ②RED RED② - ③BLU BLU③ - ④ORN ORN④ - ⑤YEL RED② - ⑥WHT	66.00 26.80 26.80 33.40 95.5 at 25 °C

Name of Parts	Model	Electrical Wiring Diagram	Wiring No.	Resistance (Ω)
Fan Motor for Indoor Unit for: RCD-1.0FSG RCD-1.5FSG	30W		BLK① - ③RED RED③ - ⑤WHT	146.7 150.6 at 20 °C
Fan Motor for Indoor Unit for: RCD-2.0FSG RCD-2.5FSG RCD-3.0FSG	80W		BLK① - ③RED RED③ - ⑤WHT	79.6 111.8 at 20 °C
Fan Motor for Indoor Unit for: RCD-4.0FSG RCD-5.0FSG	160W		BLK① - ③RED RED③ - ⑤WHT	25.21 25.84 at 20 °C
Fan Motor for Indoor Unit for: RPC-2.0FSGE RPC-2.5FSGE RPC-3.0FSGE	65W		BLK① - ②RED RED② - ③YEL YEL③ - ④GRY GRY④ - ⑤BLU RED② - ⑥WHT	59.90 16.90 15.80 15.80 63.60 at 20.1 °C
Fan Motor for Indoor Unit for: RPC-4.0FSGE RPC-5.0FSGE	180W		BLK① - ②RED RED② - ③YEL YEL③ - ④GRY RED② - ⑥WHT	32.10 24.50 24.50 44.70 at 25 °C
Fan Motor for Outdoor Unit for: RAS-5FSG RAS-5FS3	NF4501 160W		①-② ②-③	8.17 7.97
Fan Motor for Outdoor Unit for: RAS-8FSG RAS-8FS3 RAS-10FSG RAS-10FS3	NF7001 275W		①-② ②-③	5.28 4.85
Fan Motor for Outdoor Unit for: RAS-16FSG RAS-16FS3 RAS-20FSG RAS-20FS3	NF7001 275W (Right)		①-② ②-③	5.28 4.85
Fan Motor for Outdoor Unit for: RAS-16FSG RAS-16FS3 RAS-20FSG RAS-20FS3	NF7011 275W (Left)		①-② ②-③	6.74 5.91

Name of Parts	Model Code		Resistance (Ω)
Drain-up Motor for: RCI-1.0FSGE, RCI-1.5FSGE, RCI-2.0FSGE, RCI-2.5FSGE, RCI-3.0FSGE, RCI-4.0FSGE, RCI-5.0FSGE	P19837		139.1 at 21 °C
Drain-up Motor for: RCD-1.0FSG, RCD-1.5FSG, RCD-2.0FSG, RCD-2.5FSG, RCD-3.0FSG, RCD-4.0FSG, RCD-5.0FSG	KJV-1004		347 at 20 °C
Solenoid Valve for Gas Bypass for: RAS-5FSG, RAS-8FSG, RAS-10FSG, RAS-5FS3, RAS-8FS3, RAS-10FS3	ST10PA		2,018 at 20 °C
Solenoid Valve for Gas Bypass for: RAS-16FSG, RAS-20FSG, RAS-16FS3, RAS-20FS3	ST10PA		2,018 at 20 °C
4-Way Valve for: RAS-5FSG, RAS-8FSG, RAS-10FSG, RAS-5FS3, RAS-8FS3, RAS-10FS3	RAS-5FSG RAS-5FS3	CHV-0407 + CHV-01AJ503C1	1,435 at 20 °C
	RAS-8FSG RAS-8FS3 RAS-10FSG RAS-10FS3	LB6451C + VH60100	2,000 at 20 °C
4-Way Valve for: RAS-16FSG, RAS-20FSG, RAS-16FS3, RAS-20FS3	CHV-0717 + CHV-01AJ503H1		1,435 at 20 °C
Inverter Compressor Motor for: RAS-5FS3	401DHV		1,746 at 75 °C
Inverter Compressor Motor for: RAS-8FS3, RAS-10FS3, RAS-16FS3, RAS-20FS3	401DHVM		1,746 at 75 °C
Fix Compressor Motor for: RAS-8FS3	400DHM		4,006 at 75 °C
Fix Compressor Motor for: RAS-10FS3	500DHM		3,222 at 75 °C
Fix Compressor Motor for: RAS-16FS3, RAS-20FS3	600DHM		2,775 at 75 °C
Inverter Compressor Motor for: RAS-5FSG	G402DHV		1,746 at 75 °C

Name of Parts	Model	Resistance (Ω)
Inverter Compressor Motor for: RAS-8FSG, RAS-10FSG, RAS-16FSG, RAS-20FSG	G402DHVM	1,746 at 75 °C
Fix Compressor Motor for: RAS-8FSG	G401DHM	4,006 at 75 °C
Fix Compressor Motor for: RAS-10FSG	G501DHM	3,222 at 75 °C
Fix Compressor Motor for: RAS-16FSG, RAS-20FSG	G601DHM	2,775 at 75 °C
Contactora for Compressor Motor for: RAS-5FSG, RAS-8FSG, RAS-10FSG, RAS-5FS3, RAS-8FS3, RAS-10FS3	A25/FC-1S	A25:501 FC-1S:656 at 20 °C
Contactora for Compressor Motor for: RAS-16FSG, RAS-20FSG, RAS-16FS3, RAS-20FS3	A35/FC-1S	A35:501 FC-1S:656 at 20 °C

■ Checking of Compressor

CHECK LIST ON COMPRESSOR

Client:	Model:	Date:
Serial No:	Production Date:	Checker:





No.	Check Item	Check Method	Result	Remarks
1	Are THM8, THM9, THM12 and THM13 correctly connected? THM8, THM9, THM12, THM13: Discharge Gas Thermistor	① Are wires of each thermistor correctly connected by viewing? ② Check to ensure that 7-segment indication of Td1 is higher than Td2, Td3, Td4 when No.1 comp. is operating. Td1: Temperature of THM8 Td2: Temperature of THM9 Td3: Temperature of THM12 Td4: Temperature of THM13		
2	Are thermistors, THM8, THM9, THM12 and THM13 disconnected?	① Check to ensure that thermistor on the top of comp. is correctly mounted by viewing? ② Check to ensure that actually measured temp. are greatly different from the indication (Td1, Td2, Td3, Td4) during check mode.		
3	Are connectors for current sensor correctly connected	① Check to ensure that indication A1, A2, A3 and A4 are 0 during compressor stopping. ② Check to ensure that indication A1, A2, A3 and A4 are not 0 during compressor running. (However, A2, A3 and A4 are 0 during stopping of No.2, No.3 and No.4 comp.)		
4	Is current sensor faulty?			
5	Is current sensing part on PCB3 faulty?			
6	Is the direction of current sensor(CTU, CTV) reverse?	Check the direction → by viewing.		
7	Are power source wires, U and V inserted correctly into current sensor?	Check to ensure that wires are correctly inserted.		
8	Are ex. valves (MV1 and MV2) correctly connected?	Check to ensure that MV1~CN10 and MV2~CN11 are correctly connected.		
9	Are ex. valve coils (MV1 and MV2) correctly mounted?	Check to ensure that each coil is correctly mounted on the valve.		
10	Are the refrigeration cycle and electrical wiring system incorrectly connected?	Check to ensure that refrigerant is flowing into indoor units by operating one refrigerating cycle only from the outdoor unit.		
11	Is opening of ex. valve completely closed(locked)?	Check the following by the check mode of outdoor unit. ① Liquid Pipe Temp.(TL)<Air Intake Temp.(Ti) during Cooling Operation ② Liquid Pipe Temp.(TL)>Air Intake Temp.(Ti) during Heating Operation		
12	Is opening of ex. valve fully opened (locked)?	Check to ensure that liquid pipe temp. is lower than air intake temp. of stopping indoor unit when other indoor units are operating under cooling operation.		
13	Are the contacts for comp. magnetic switch CMC faulty?	Check the surface of each contact (L1, L2 and L3) by viewing.		
14	Is there any voltage abnormality among L1-L2, L2-L3 and L3-L1?	Check to ensure that voltage imbalance is smaller than 3%. Please note that power source voltage must be within 380V or 415V±10%, 220V±10 %.		
15	Is the comp. oil acidified during compressor motor burning?	Check to ensure that the oil color is not black.		

Additional Information for "CHECK LIST ON COMPRESSOR"

Check Item	Additional Information (Mechanism of Compressor Failure)
1 & 2	The liquid refrigerant return volume to the compressor is controlled by the discharge gas temperature Td1 when only No.1 compressor is operating. If Td1 and Td2 are reversely connected, the liquid refrigerant return volume will become small by detecting the temperatures even if the actual discharge gas temperature is high. Therefore, this abnormal overheating operation will result in insulation failure of the motor winding.
3, 4 & 5	Overcurrent control (operating frequency control) is performed by detecting current by the current sensor. In this case, winding insulation failure will occur, since control is not available in spite of actually high current.
6, 7	The current sensor checks phase and adjusts output electrical wave in addition to the above mentioned items. If fault occurs, the output electrical wave becomes unstable giving stress to the motor winding, resulting in winding insulation failure.
8, 9	During a cooling operation, Pd is controlled by fan revolution of outdoor unit, and Td and SH are controlled by MV of each indoor units. During a heating operation, Td and SH are controlled by MV1 and MV2. If expansion valves are incorrectly connected, correct control is not available, resulting in compressor seizure depending on liquid refrigerant returning conditions or motor winding insulation failure depending on overheating conditions.
10	If the refrigeration cycle and electrical system are incorrectly connected, abnormally low suction pressure operation is maintained or abnormally high discharge pressure operation is maintained, resulting in giving stress to the compressor, since their correct control is not available.
11	ditto
12	The compressor may be locked due to the liquid return operation during the cooling operation.
13	In the case that the contacting resistance becomes big, voltage imbalance among each phase will cause abnormal overcurrent.
14	In this case, overcurrent will occur, efficiency will decrease or the motor winding will be excessively heated.
15	In the case, it will result in motor burning or compressor seizure.

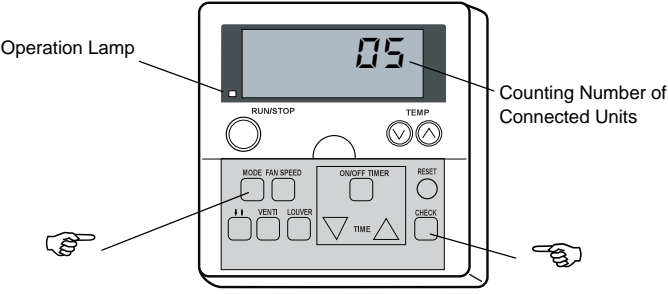
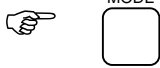
1.4 TEST RUN

1.4.1 TEST RUN MODE BY REMOTE CONTROL SWITCH

①	Turn ON the power source of the Indoor and Outdoor Units				
②	Set the TEST RUN mode by remote control switch. Depress the "MODE" and the "CHECK" switches simultaneously for more than 3 seconds. <ol style="list-style-type: none"> If "TEST RUN" and the counting number of the connected units to the remote control switch (for example "05") are indicated on the remote control switch, the connection of remote control cable is correct. Go to ④ If no indication or "00" appear or the number of the units indicated is smaller than the actual number of the units, some abnormalities exist. Go to ③ 				
③	Remote Control Switch Indication	Fault	Inspection Points after Power Source OFF		
	No indication	The power source is not turned ON. The connection of the remote control cable is incorrect. The connecting wires of power supply line are incorrect or loosened.	<ol style="list-style-type: none"> Connection between the connector and the wires: Red wire-No. 1, Black wire-No. 2, White wire-No. 3 Connecting Points of Remote Control Cable Contact of Connectors of Remote Control Cable Connection Order of each Terminal Board Screw Fastening of each Terminal Boards. Dip Switch Setting on Printed Circuit Board Wire Connecting Order of Bridge cable Connecting Points of Bridge Cable Contact of Connectors of Bridge Cable 		
	Counting number of connected units is incorrect	The setting of unit number is incorrect The connection of control cables between each indoor units are incorrect. (When one remote control switch controls multiple units)	<ol style="list-style-type: none"> Connection between the connector and the wires: Red wire-No. 1, Black wire-No. 2, White wire-No. 3 Connecting Points of Remote Control Cable Contact of Connectors of Remote Control Cable Connection Order of each Terminal Board Screw Fastening of each Terminal Boards. Dip Switch Setting on Printed Circuit Board Wire Connecting Order of Bridge cable Connecting Points of Bridge Cable Contact of Connectors of Bridge Cable 		
	Back to ① after checking				
④	Select TEST RUN MODE by depressing MODE Switch (COOL OR HEAT)				
⑤	Depress RUN/STOP switch. <ol style="list-style-type: none"> The "TEST RUN" operation will be started. (The "TEST RUN" operation will be finished after 2 hours unit operation or by depressing the RUN/STOP switch again). IF the unit do not start or the operation lamp on the remote control switch is flickered, some abnormalities exist. Go to ⑥ 				
⑥	Remote Control Switch Indication	Unit Condition	Fault	Inspection Points after Power Source OFF	
	The operation lamp flickers. (1 time/1 sec.) And the Unit No. and Alarm Code "03" flicker	The unit does not start.	The connecting wires of operating line are incorrect or loosened.	<ol style="list-style-type: none"> Connecting Order of each Terminal Boards. The fuse on the PCB may be blown out due to miswiring. (Can be recovered only once by the DSW on the PCB). (See ⑦) Screw fastening of each Terminal Boards. Connecting Order of Power Line Between Indoor Units and Outdoor Unit. 	
	The operation lamp flickers. (1 time/2 sec.)	The unit does not start.	The connection of remote control cable is incorrect	This is the same as item ③ 1, 2, and 3	
	Indication of flicker different to above	The unit does not start, or start once and then stops	The connection of thermistor or other connectors are incorrect. Tripping of protector exists, or else.	Check by the alarm code table. (Do it by service people).	
	Normal	The outdoor fans rotate reversely	The connection order of power supply line is incorrect.	Connecting Order of the Terminal Board: TB1 in the Outdoor Unit	
		The outdoor fans do not start.	Some wires of power supply line are disconnected.	Connecting Point of Power Supply Line. Contact Outdoor Fan Motor Connector.	
⑦	Procedure for Recovery When Transmitting Circuit Fuse is Blown Out: <ol style="list-style-type: none"> Correct the wiring for the terminal board. Switch the 2nd pin of the DSW on the PCB to "ON" 			Indoor PCB DSW7 	Outdoor PCB DSW10 

1.4.2 TEST RUN MODE BY OUTDOOR UNIT

The procedure of test run from outdoor unit side is indicated below. Setting of this DIP switch is available with the power source ON.

⚠ WARNING:

- Do not touch any other electrical parts when operating switches on the PCB.
- Do not attach or detach service cover when the power source for the outdoor unit is ON and the outdoor unit is operated.
- Turn all DIP switches of DSW4 OFF when the test run operation is completed.

Setting of Dip Switch (Before Shipment)

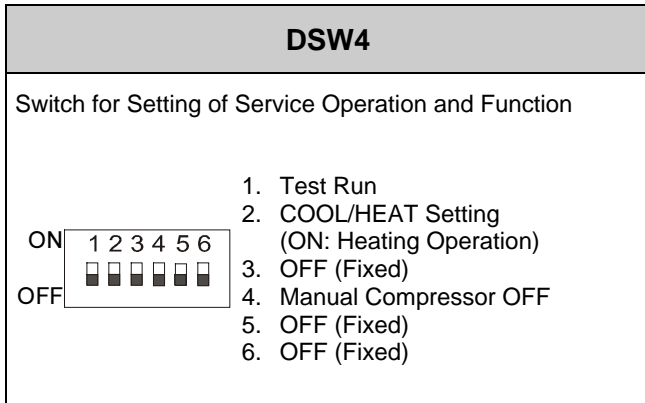

Outdoor Unit Printed Circuit Board (PCB1)

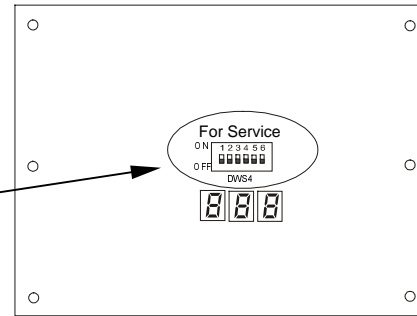

	Dip Switch Setting	Operation	Remarks
Test Run	<ol style="list-style-type: none"> Setting of Operation Mode Cooling: Set DSW4-2 OFF. ON 1 2 3 4 5 6 OFF 1 2 3 4 5 6 Heating: Set DSW4-2 ON. ON 1 2 3 4 5 6 OFF 1 2 3 4 5 6 Starting Test Run Set DSW4-1 ON and the operation is started after a few ~20 seconds. When heating operation, leave DSW4-2 at ON ↓ ON 1 2 3 4 5 6 OFF 1 2 3 4 5 6 	<ol style="list-style-type: none"> The indoor unit automatically start to operate when the test run of the outdoor unit is set. The ON/OFF operation can be performed from the remote control switch or DSW4-1 of the outdoor unit. Continuous operation during 2 hours is performed without Thermo-OFF. 	<ul style="list-style-type: none"> Take care that the indoor units start operation in accord with the test run operation of the outdoor unit. The test run is started from the outdoor unit and stopped from the remote control switch, the test run function of the remote control switch is cancelled. However, the test run function of the outdoor unit is not cancelled In case that the plural indoor units are connected with one remote control switch, all the units start test run operation at the same time, therefore, turn the power source OFF for the indoor units not to operate test run. In this case, the "TEST RUN" indication of the remote control switch may flicker, and this is not abnormal. The setting of DSW4 is not required for the test run from the remote control switch.
Manual OFF of Compressor	<ol style="list-style-type: none"> Setting - Compressor Manual OFF: Set DSW4-4 ON. ON 1 2 3 4 5 6 OFF 1 2 3 4 5 6 - Compressor ON: Set DSW4-4 OFF. ON 1 2 3 4 5 6 OFF 1 2 3 4 5 6 	<ol style="list-style-type: none"> When DSW4-4 is ON during compressor operation, the compressor stops to operate immediately and the indoor unit is under the condition of Thermo-OFF. When DSW4-4 is OFF, the compressor starts to operate after the cancellation of 3-minutes guard. 	<ul style="list-style-type: none"> Do not repeat compressor ON/OFF frequently.
Manual Defrost	<ol style="list-style-type: none"> Manual Defrost Operation Starts Press PSW1 for more than 3 seconds during heating operation, the defrost operation is started after 2 minutes. This function is not available within 5 minutes after starting heating operation Manual Defrost Operation Finishes Defrost operation is automatically ended and the heating operation is started. 	<ol style="list-style-type: none"> Defrost operation is available regardless of frosting condition and total time of heating operation. Defrost operation is not performed when the temperature of outdoor heat exchanger is higher than 10°C, high pressure is higher than 2.0MPa (20kgf/cm²G) or Thermo-OFF. 	<ul style="list-style-type: none"> Do not repeat defrost operation frequently. When manual defrost operation is accepted by PSW1, the time left before starting defrost operation is indicated at the 7-segment indicator on the PCB. <p>Time left (every 4 seconds)</p>

1.4.3 CHECKING LIST (FSG AND FS3 SERIES)

■ CHECK LIST ON TEST OPERATION

Client:			Installer:			Date:		
Outdoor Unit Model:			Outdoor Unit Serial No.:			Checker:		
Indoor Unit Model								
Indoor Unit Serial No.								

Piping Length (m)	
Additional Refrigerant Charge (kg)	

1. General

No.	Check Item	Result
1	Was the dip switch, DSW6 for piping length in Outdoor Unit set?	
2	Was the dip switch, DSW3 for piping lift in Outdoor Unit set?	
3	Is the transmitting wire contacting to power lines?	
4	Was an earth wire connected?	
5	Is there any short circuit?	
6	Is there any voltage abnormality among each phase (L1-L2, L2-L3, L3-L1, L1-N)?	

2. Refrigeration Cycle

a. Operation (Cooling/Heating)

No.	Check Item	Result
1	Operate all the indoor units ("TEST RUN" mode).	
2	Operate all the indoor units at "HIGH" speed.	
3	In case that the constant compressor is turned ON and OFF repeatedly, stop one indoor unit (small capacity one).	

b. Sampling Data

No.	Check Item	Result
1	After the operation for more than 20 min.	
2	Check Pd and Td. Is TdSH 20 to 40 deg.?	
3	Is Ps 0.2 to 0.5?	
4	Is Pd 1.2 to 2.2? (If the outdoor temperature is high, Pd becomes high.)	

3. Check Item after Sampling Data

a. Cooling Operation (It is applicable when outdoor temperature is higher than 15 °C)

No.	Check Item	Standard	Causes	Result
1	Is $\underline{H1}$ (Compressor Frequency) + (\underline{CC} (Numbers of Running Compressor)-1) X (❖) abnormally low or high? (It is applicable when Intake Air Temp. is 3 deg. higher than Setting Temp.)	Running Horsepower of Indoor Units X 15Hz	Low: Insufficient Refrigerant High: Excessive Refrigerant DSW for I.U. Capacity; Incorrect Setting	
2	Is fan actually running at "HIGH" speed when \underline{FQ} (Air Flow Rate of Fan) is 「15」 or 「16」?	—	Fan Motor; Failure PCB; Failure Condenser; Failure	
3	Is Td1 higher than Td2 when only No. 1 compressor is running (when \underline{CC} (Numbers of Running Compressor) is 「1」)?	—	Td Thermistor; Incorrect Connection or Incorrect Mounting	
4	Is the total of \underline{iE} (Indoor Ex. Valves Opening) abnormally low or high?	Total of \underline{iE} : Horsepower of Outdoor Unit X (5~30)	Low: Excessive Refrigerant High: Insufficient Refrigerant	
5	Is TL(Liquid Pipe Temp. of I.U. Heat Exchanger) lower than Ti(Intake Air Temp. of I.U.)?	It is normal when TL-Ti < -5.	TL Thermistor; Failure Ex. Valve; Fully Closed Short-circuit	
6	Is TG(Gas Pipe Temp. of I.U. Heat Exchanger) lower than Ti(Intake Air Temp. of I.U.)?	It is normal when TG-Ti < -5.	TG Thermistor; Failure Ex. Valve; Fully Closed or Slightly Open Short-circuit	
7	Is there any excessive difference among I.U. at $\underline{SHTG-TL}$ of I.U. heat exchanger? (It is applicable when Intake Air Temp. is 3 deg. higher than Setting Temp.)	It is normal if the difference among units is within 7 deg.	TL/TG Thermistor; Failure Ex. Valve; Fully Open, Slightly Open or Fully Closed	
8	Is there any I.U. with the I.U. heat exchanger $\underline{SHTG-TL}$ excessively different from other units' value and is \underline{iE} lower than 「7」? (It is applicable when Intake Air Temp. is 3 deg. higher than Setting Temp.)	It is normal if SH is within 3 deg. lower than other units.	Ex. Valve; Locked with Fully Open	
9	Is there any I.U. with SH excessively lower than other units' value, under the condition of \underline{iE} (I.U. Ex. Valve) 「100」?	It is normal if SH is within 3 deg. higher than other unit	Ex. Valve; Locked with Slightly Open or Closed	
10	Is the difference between Discharge Air Temp. and Intake Air Temp. more than 7 deg.?	—	—	

NOTES:

1. The symbol with an underline indicates checking item and the mark 「 」 indicates checking data.
2. Regarding (❖), the following value should be applied.

Power Supply	Mark ❖		
	8HP	10HP	16, 20HP
380-415V 50Hz	50	62	70

b. Heating Operation (It is applicable when outdoor temperature is higher than 0 °C)

No.	Check Item	Standard	Causes	Result
1	Is $\underline{oE1}$ (O.U. Ex. Valves Opening) abnormally low or high when TdSH is 15 to 30 deg.?	$\underline{oE1} = 30\sim 70\%$	Low: Insufficient Refrigerant High: Excessive Refrigerant	
2	Is Pd $\lceil 1.6 \rceil$ to $\lceil 2.2 \rceil$? (Pd is high when the indoor temperature is high.)	—	Low: Solenoid Valve SVA Leakage High: Excessive Gas Pipe Resistance	
3	Is $\underline{H1}$ (Compressor Frequency) + (\underline{CC} (Numbers of Running Compressor)-1) (\diamond) abnormally low or high? (The lower is the room temp. and outdoor temp., the higher is the above value.)?	—	Low: Excessive Refrigerant High: Insufficient Refrigerant, Excessive Pipe Resistance	
4	Is Ps $\lceil 0.2 \rceil$ to $\lceil 0.5 \rceil$? (Only under the condition that electrical expansion valve SVA is OFF.)	—	Low: O.U. Short-circuit Low/High: O.U. Fan Thyristor Failure or Outdoor Air Sensor; Failure	
5	Is the temperature difference between I.U.* more than 15 deg. when \underline{iE} (I.U. Ex. Valve) is 100? *The temperature difference between I.U. means the following; b3(Discharge Gas Temp.) - b2(Intake Air Temp.) indicated on the remote control switch by check mode. However, this is applicable only when b2(Intake Air Temp.) - b1(Setting Temp.) is higher than 3 deg.	—	Failure such as P.C.B., Wiring, Coil, Valve Excessive Pipe Resistance Thermistor Failure for Discharge Air	

NOTES:

1. The symbol with an underline indicates checking item and the mark $\lceil \rceil$ indicates checking data.
2. Regarding (\diamond), the following value should be applied.

Power Supply	Mark \diamond		
	8HP	10HP	16, 20HP
380-415V 50Hz	50	62	70

2 SERVICING

2.1 OUTDOOR UNIT

! **WARNING:** TURN OFF all power source switches

2.1.1 REMOVING AIR INTAKE GRILLE

1. Remove two (2) screws for the air intake grille at the rear side of the unit.
2. Remove the air intake grille by pulling and unhooking four (4) hooks at both sides.

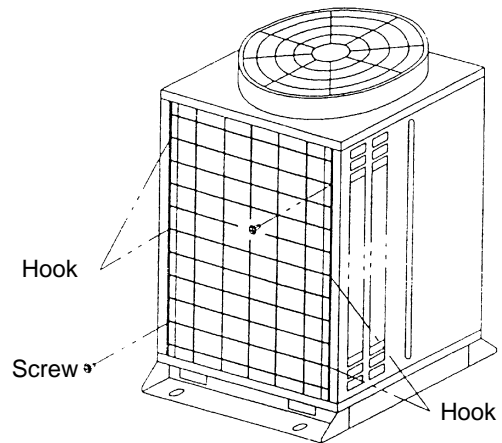

2.1.2 REMOVING FRONT SERVICE PANEL

1. Remove five (5) screws. Slightly lift the panels upwards and remove them.

Note:

When removing screws for front service panel, remove the screw at the lower part of panel firstly

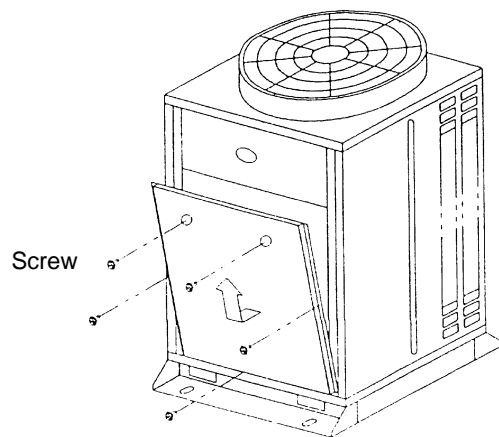

2.1.3 REMOVING FAN GUARD NETS

1. Remove four (4) screws and remove the fan guard net

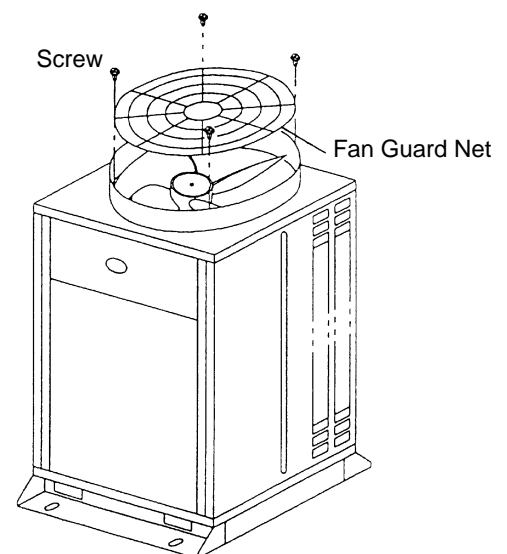

⚠ WARNING: TURN OFF all power source switches

2.1.4 REMOVING OUTDOOR FAN

1. Remove the fan guard nets according to item 2.1.3, "Removing Fan Guard Nets".
2. Remove the fans by removing the cap nuts and flat washers fixing the propeller fans onto the motor shafts. If it is difficult to remove the fan, use a puller.

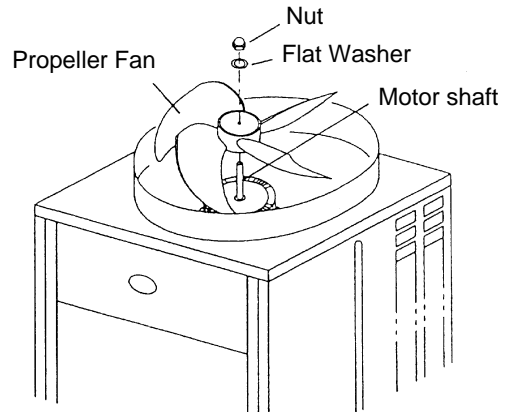

Electrical Box

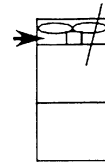

RAS-5FSG, 5FS3
RAS-8FSG, 8FS3
RAS-10FSG, 10FS3

Electrical Box

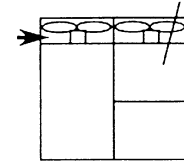

RAS-16FSG, 16FS3
RAS-20FSG, 20FS3

3. Removing Wires
 - a. Remove two screws fixing the electrical box cover and remove the electrical box cover.
 - b. Disconnect the connectors for the motors in the electrical box.
 - c. Remove the motors by removing four fixing bolts for the motors.

Notes:

1. Make the cord outlet of the motor directing downward when mounting the motor.
2. Firmly fix the motor wires onto the motor clamp with the plastic tie, not to touch the propeller fans.
3. Mounting Propeller Fan
Put and push the propeller fan by identifying the  mark with the cut part of the motor shaft. Firmly fix the propeller fan twice with a tightening torque of 30N·m (300 kg·cm) after the head of the fan shaft comes up.
4. Connect the motor wires to the electrical connecting part at the upper part of the electrical box.

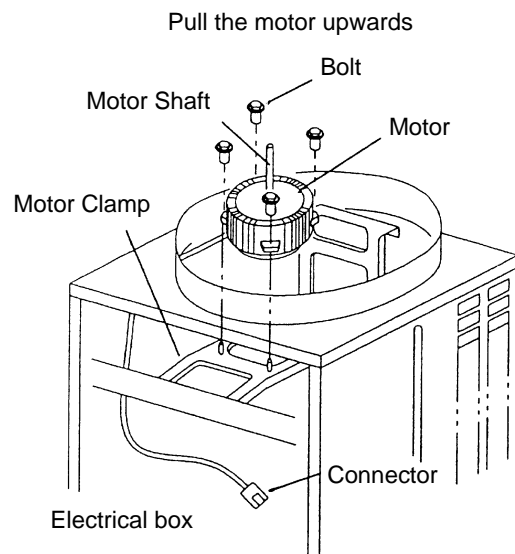

WARNING: TURN OFF all power source switches

2.1.5 REMOVING COMPRESSOR (RAS-5FSG AND RAS-5FS3)

- Do not expose the inner refrigeration cycle to the atmosphere for a long period of time when replacing a compressor to protect the cycle from mixing water or foreign particles. If exposed for a long time, seal pipe ends using caps or tape.
- Remove the caps for the compressor just before replacing the compressor.
- Check to ensure each terminal No. when connecting compressor power wires. If incorrectly connected, the compressor will fail due to reverse rotation.

Before starting this work, collect refrigerant into a cylinder from the cycle.

1. Remove front service panel according to the item 2.1.2, "Removing Front Service Panel".
2. Release the lace for top cap of the compressor and remove the top cap.
3. Remove the Td thermistor on the top of the compressor.

Note:

The thermostat fixer, holder, thermostat holder are used again when reassembling. Keep them in a box so that the parts are stored correctly.

4. Release the lace for the water-proof cover, open the water-proof cover from the front side.

Note:

Remove the water-proof cover in the arrow mark direction as shown by paying attention to the cut part of the water-proof cover in order to avoid any damages.

5. Remove the terminal cover for the compressor and disconnect the wiring to the compressor terminals. Check to ensure that the terminals Nos. are indicated. If the terminal Nos. are not identified, this will cause incorrect wiring when reassembling.

Notes:

- 1 Check to ensure that the faston terminals for the compressors are normal. When a pulling force of 2kg or more is required, it is normal. If abnormal, replace the faston terminals with new ones.
- 2 Check to ensure that wires are firmly fixed.
- 3 It is recommended that the faston terminals be clamped to increase a contacting force after replacing the compressor.

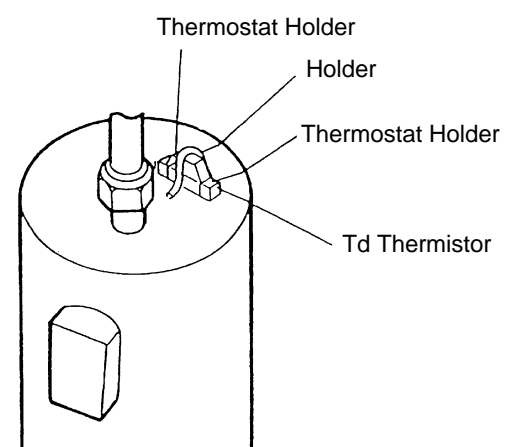
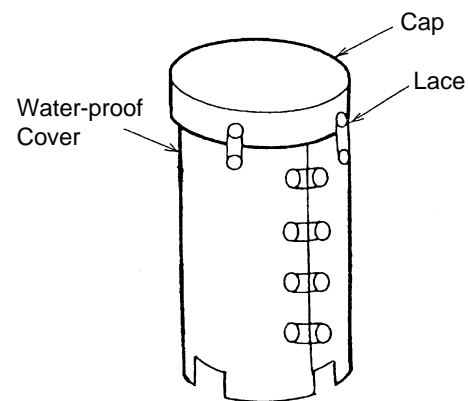

Direction to remove the cover →

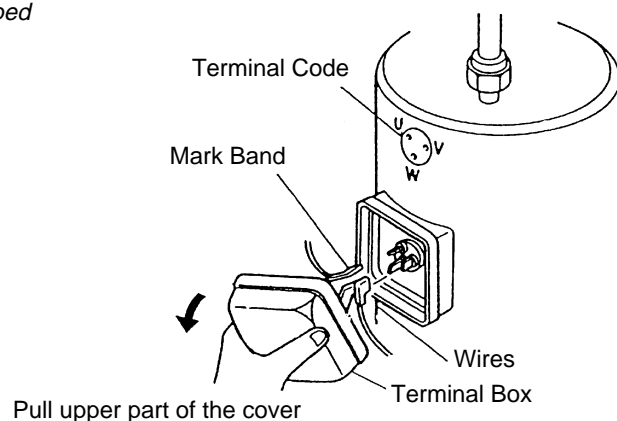
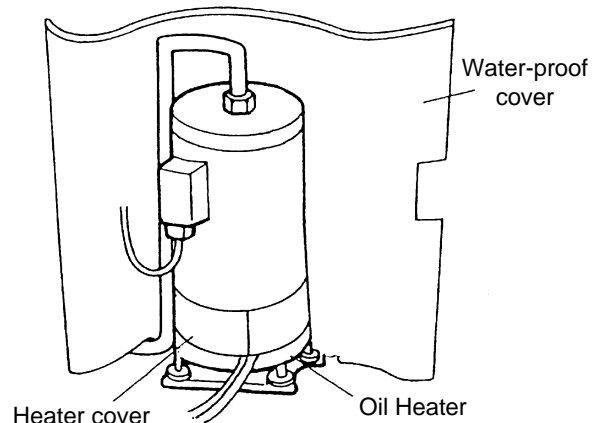

⚠ WARNING: TURN OFF all power source switches

6. Remove the heater cover and the spring for the oil heater, and release the oil heater.

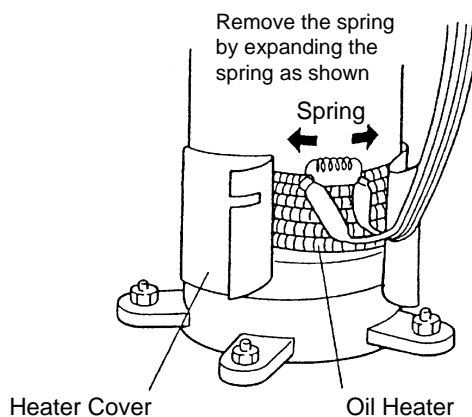

7. Disconnect the discharge pipe of the compressor. Use two spanners when disassembling the flare-nuts.

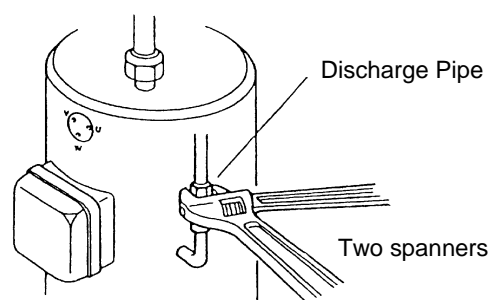

8. Disconnect the suction pipe of the compressor. Use two spanners when disassembling the flare-nuts.

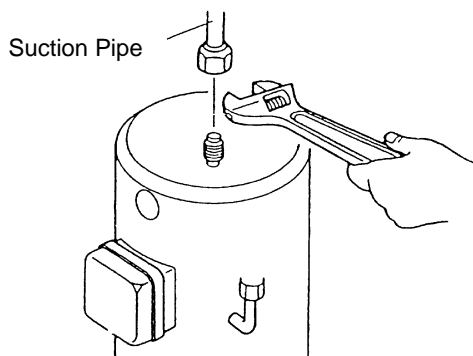

Notes:

- 1 Completely wipe off the oil if the oil is spread to the other parts such as the compressor cover, wiring, bottom base, etc. If not, this will cause many problems to the unit.
- 2 If the oil is spilt, charge new oil equivalent to the spilt oil.
- 3 Check to ensure that the oil is not foul. If foul, replace it with new one.

9. Remove three nuts fixing the compressor and remove the compressor.

Note:

When lifting the compressor, hold the discharge pipe vertically and turn it to the right, and pull the compressor towards the front side by paying attention to the compressor leg not to touch the suction pipe.

10. Regarding remounting the compressor work, perform the above work in the reverse processes.

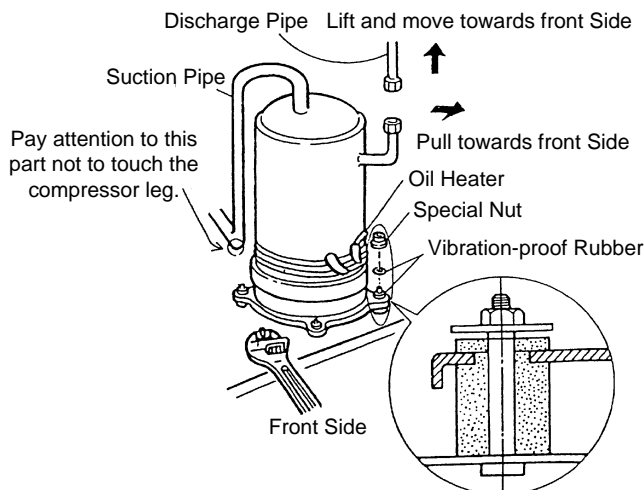

Pull out the compressor toward the front side, and remove the vibration absorbing rubbers.

WARNING: TURN OFF all power source switches

2.1.6 REMOVING COMPRESSORS (RAS-8FSG, RAS-10FSG, RAS-16FSG, RAS-20FSG, RAS-8FS3, RAS-10FS3, RAS-16FS3 AND RAS-20FS3)

- Do not expose the inner refrigeration cycle to the atmosphere for a long period of time when replacing a compressor to protect the cycle from mixing water or foreign particles. If exposed for a long time, seal pipe ends using caps or tape.
- Remove the caps for the compressor just before replacing the compressor.
- Check to ensure each terminal No. when connecting compressor power wires. If incorrectly connected, the compressor will fail due to reverse rotation.

Before starting this work, collect refrigerant into a cylinder from the cycle.

1. Remove front service panel according to the item 2.1.2, "Removing Front Service Panel".
2. Release the lace for top cap of the compressor and remove the top cap.
3. Remove the Td thermistor on the top of the compressor.

Note:

The thermostat fixer, holder, thermostat holder are used again when reassembling. Keep them in a box so that the parts are stored correctly.

4. Release the lace for the water-proof cover, open the water-proof cover from the front side.

Note:

Remove the water-proof cover in the arrow mark direction as shown by paying attention to the cut part of the water-proof cover in order to avoid any damages.

5. Remove the terminal cover for the compressor and disconnect the wiring to the compressor terminals. Check to ensure that the terminals Nos. are indicated. If the terminal Nos. are not identified, this will cause incorrect wiring when reassembling.

Notes:

- 1 Check to ensure that the faston terminals for the compressors are normal. When a pulling force of 2kg or more is required, it is normal. If abnormal, replace the faston terminals with new ones.
- 2 Check to ensure that wires are firmly fixed.
- 3 It is recommended that the faston terminals be clamped to increase a contacting force after replacing the compressor.

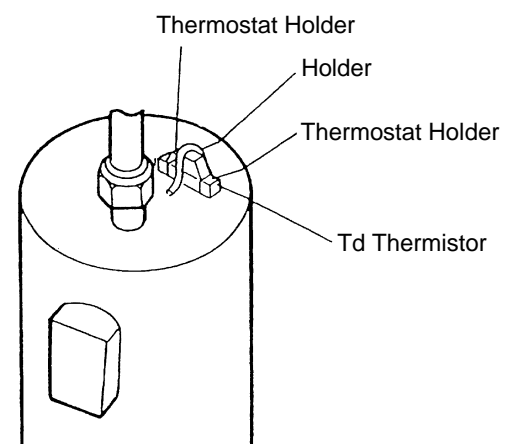
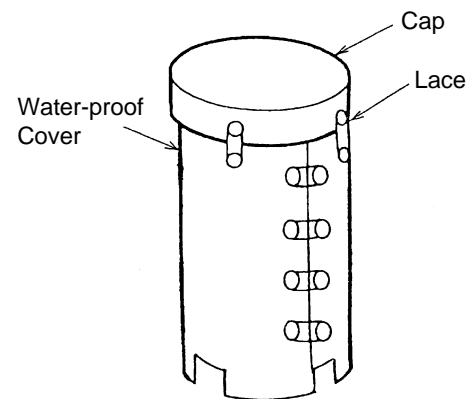

Direction to remove the cover →

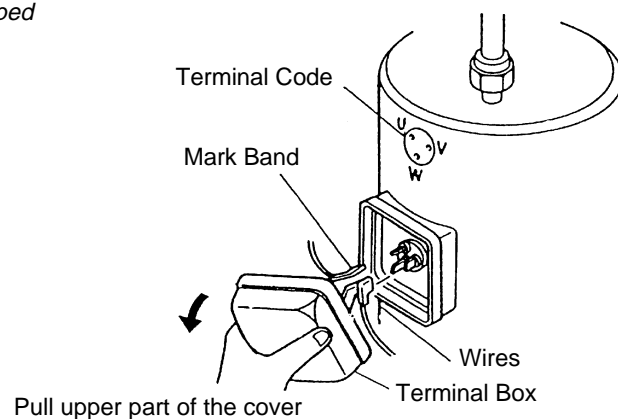
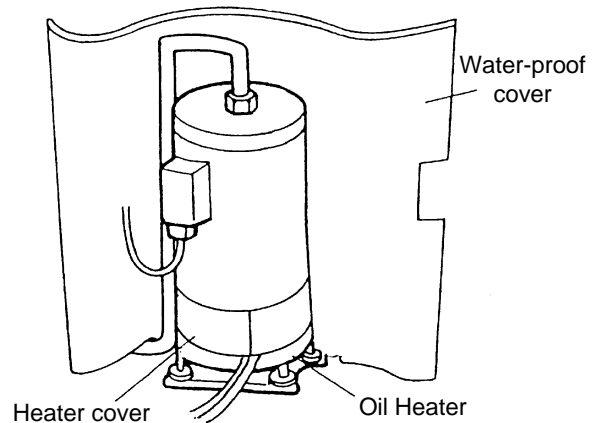

⚠ WARNING: TURN OFF all power source switches

6. Remove the heater cover and the spring for the oil heater, and release the oil heater.

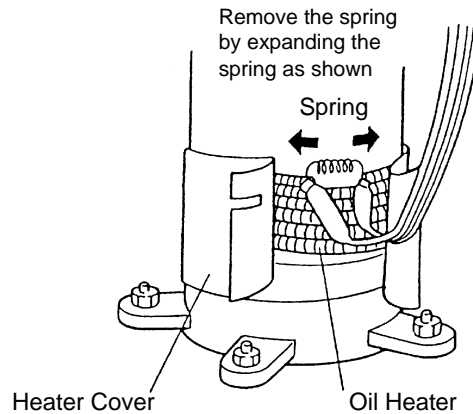

7. Disconnect the discharge pipe of the compressor. Use two spanners when disassembling the flare-nuts.

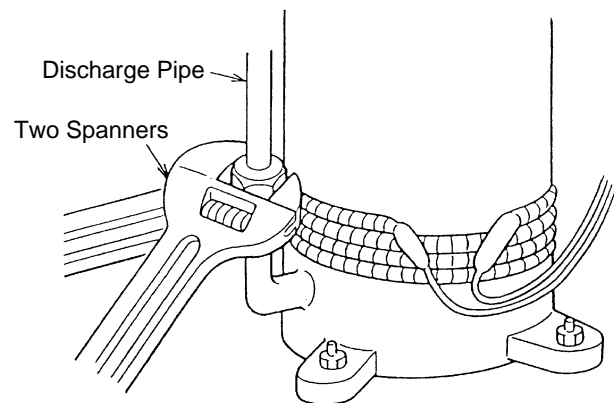

8. Remove the flare-nut at the compressor side, and disconnect the oil piping. There is a possibility that the oil may flow from the inside of the oil pipe. Therefore, prepare an oil pan, etc. to collect the oil.

Notes:

- 1 Completely wipe off the oil if the oil is spread to the other parts such as the compressor cover, wiring, bottom base, etc. If not, this will cause many problems to the unit.
- 2 If the oil is spilt, charge new oil equivalent to the spilt oil.
- 3 Check to ensure that the oil is not foul. If foul, replace it with new one.

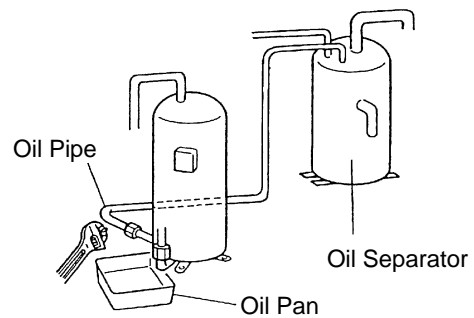

9. Remove the suction pipe of the compressor.

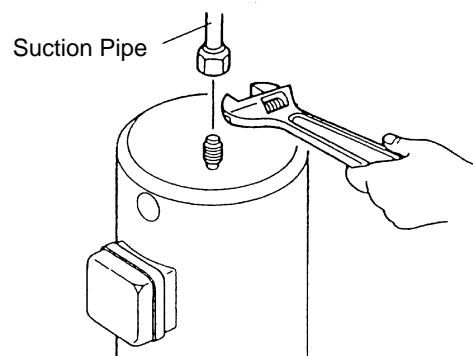

WARNING: TURN OFF all power source switches

- Remove three nuts fixing the compressor and remove the compressor.
There is no nut at the left rear side.

Notes:

- Pull out the compressor without removing the oil heater. Remove the oil heater after the compressor is put outside the unit. (Constant Comp. Only)
 - When lifting the compressor, hold the discharge pipe vertically and turn it to the left and pull the compressor towards the front side by paying attention to the compressor leg not to touch the suction pipe.
- Regarding remounting the compressor work, perform the above work in the reverse processes.

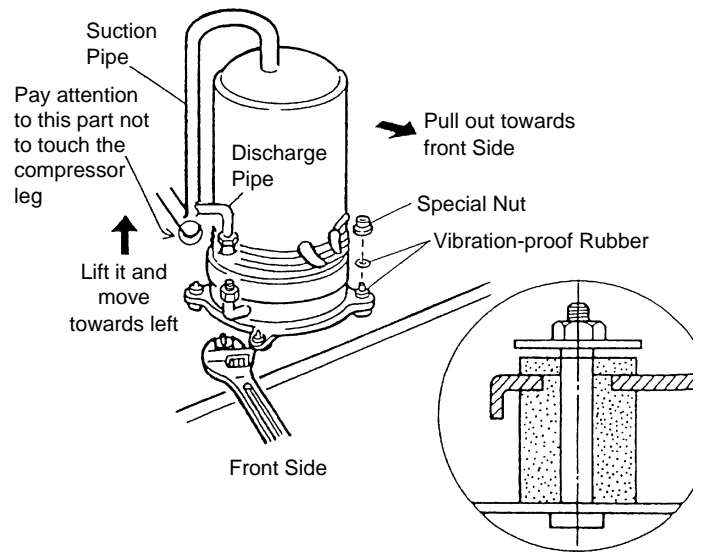

2.1.7 REMOVING HIGH PRESSURE SWITCH, HIGH PRESSURE SENSOR AND LOW PRESSURE SENSOR

- Remove the front service panel according to item 2.1.2.
- Collect all refrigerant from the low pressure side check joint when the high pressure switch is removed. Use two spanners when removing the pressure sensors.

Note:

The figures are viewed from the front side

RAS-5FSG and RAS-5FS3

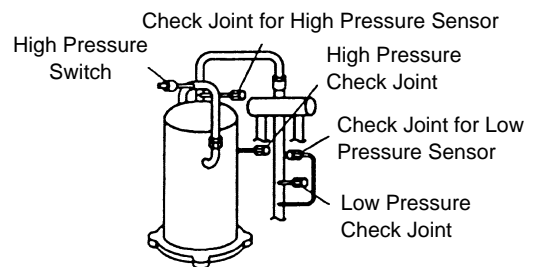

RAS-8FSG, RAS-10FSG, RAS-8FS3, RAS-10FS3

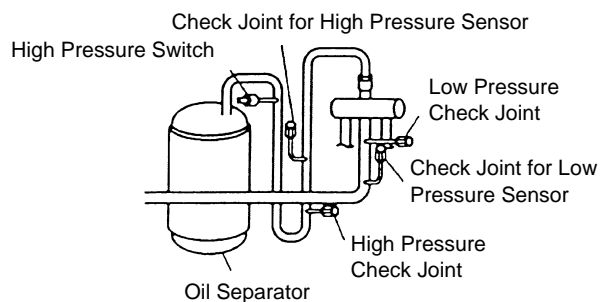

RAS-16FSG, RAS-20FSG, RAS-16FS3, RAS-20FS3

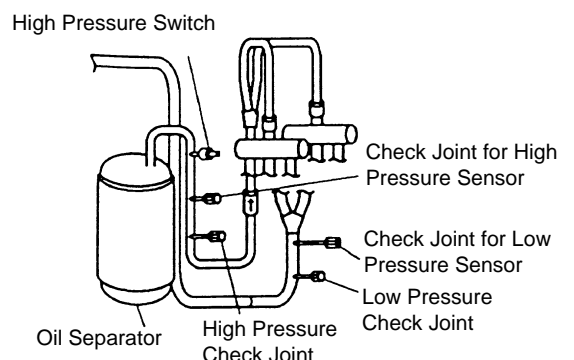

⚠ WARNING: TURN OFF all power source switches

A-1. Removing High Pressure Switch
(RAS-5FSG, RAS-8FSG, RAS-10FSG,
RAS-5FS3, RAS-8FS3 and RAS-10FS3)

- ❶ Disconnect the faston terminals
- ❷ Remove the high pressure switch from the brazing part of the discharge pipe by a burner

Note:

Do not expose the refrigeration cycle to the atmosphere for a long period to avoid mixing of water and foreign particles into the refrigeration cycle. If exposed for a long period, seal the hole.

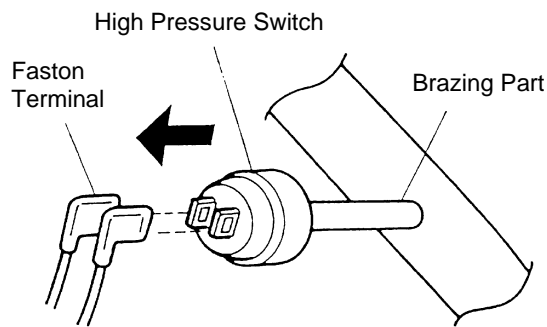

A-2. Removing High Pressure Switch
(RAS-16FSG, RAS-20FSG, RAS-16FS3 and RAS-20FS3)

- ❶ Disconnect the high pressure switch from the union

Note:

Do not expose the refrigeration cycle to the atmosphere for a long period to avoid mixing of water and foreign particles into the refrigeration cycle. If exposed for a long period, seal the hole.

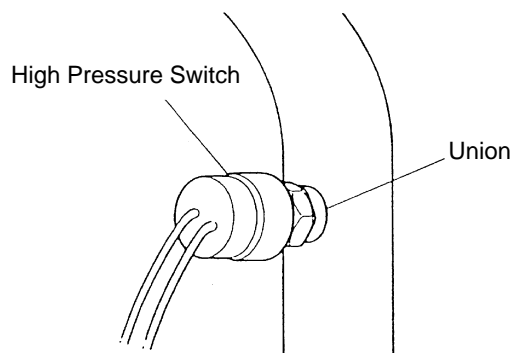

B. Removing High Pressure Sensor and Low Pressure Sensor

- ❶ Remove the water-proof caps

Note:

The water-proof caps are used after replacing pressure sensors.

- ❷ Remove the pipe of the high pressure sensor or low pressure sensor using two spanners. Firstly remove the check joint at the main pipe side.
- ❸ Remove the connector for the pressure sensors.
- ❹ Remove the high pressure sensor or low pressure sensor after removing each two (2) fixing screws for the pressure sensors.

Note:

Put the water-proof caps on the pressure sensors again after replacing pressure sensors.

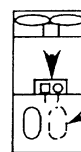
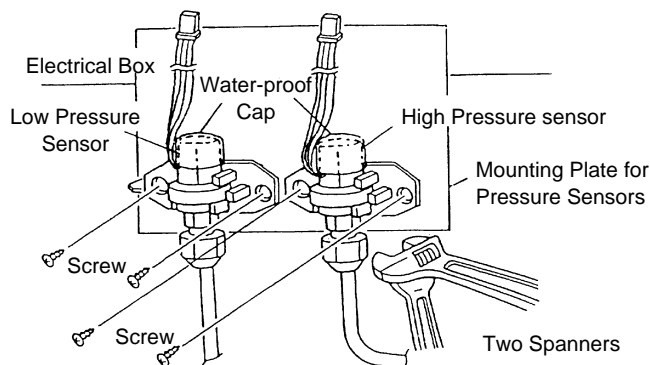

RAS-5FSG, 5FS3,
RAS-8FSG, 8FS3,
RAS-10FSG, 10FS3

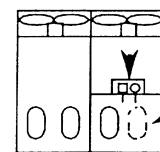

RAS-16FSG, 16FS3
RAS-20FSG, 20FS3

Firstly remove the main pipe at the check joint.
If the sensor side is removed refrigerant will be discharged.

⚠ WARNING: TURN OFF all power source switches

2.1.8 REMOVING COIL FOR REVERSING VALVE

⚠ DANGER:

Do not touch the electrical parts when the LED3(Red) on the SNUBBER PCB(PCB5) or the LED2(Red) on the Inverter PCB(PCB3) is lit, since the voltage is higher than 50V.

1. Remove the front service panel according to the item, 2.1.2, "Removing Front Service Panel".
2. Remove the coil for the reversing valve as shown below.

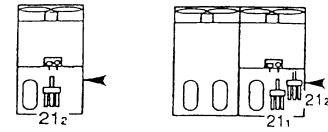

RAS-5FSG, 5FS3,
RAS-8FSG, 8FS3,
RAS-10FSG, 10FS3

RAS-16FSG, 16FS3
RAS-20FSG, 20FS3

The arrow mark (←) indicates the position of the reversing valve coil. The figure is the front view one.

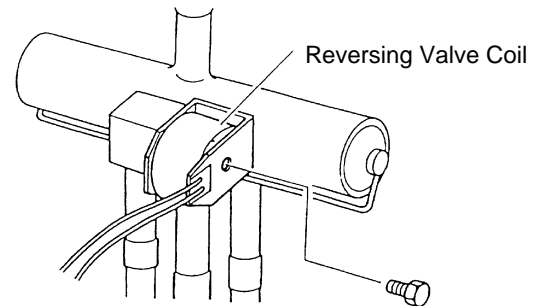

2.1.9 REMOVING COIL FOR SOLENOID VALVE

1. Remove the front service panel according to the item, 2.1.2, "Removing Front Service Panel".
2. Remove the fixing screw (1 piece) for solenoid valve coil.
3. Remove the solenoid valve coil after removing the fixing screw (1 piece) for the solenoid valve.
(In Case of SVA for Gas Bypass)

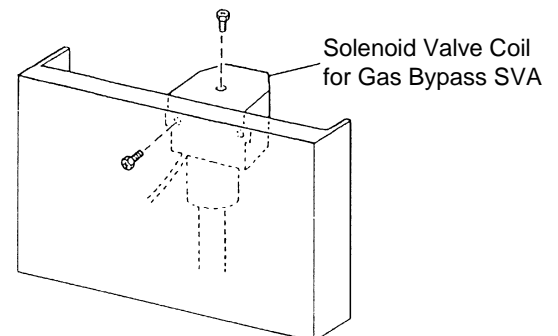

2.1.10 REMOVING THERMISTOR FOR LIQUID PIPE

⚠ DANGER:

Do not touch the electrical parts when the LED3(Red) on the SNUBBER PCB(PCB5) or the LED2(Red) on the Inverter PCB(PCB3) is lit, since the voltage is higher than 50V.

1. Remove the front service panel according to the item, 2.1.2, "Removing Front Service Panel".
2. Remove two screws fixing the electrical box cover and remove the electrical box cover.

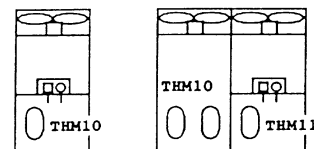

RAS-5FSG, 5FS3,
RAS-8FSG, 8FS3,
RAS-10FSG, 10FS3

RAS-16FSG, 16FS3
RAS-20FSG, 20FS3

⚠ WARNING: TURN OFF all power source switches

3. Pull out the fixing plate for the thermistor from the pipe after detaching the CORK TAPE, and remove the thermistor for the liquid pipe.

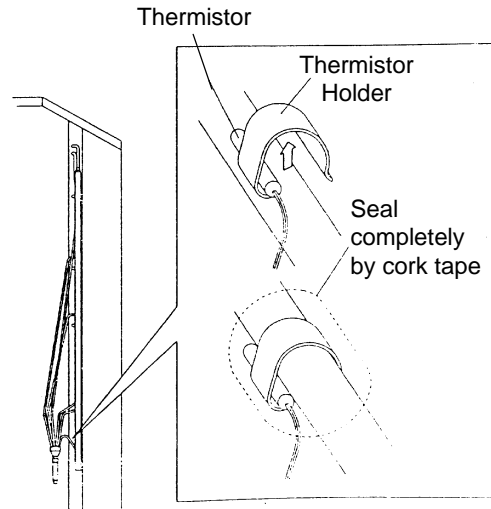

2.1.11 REMOVING REVERSING VALVE

Before starting this work, collect refrigerant into a cylinder from the cycle and turn off all power source switches.

1. Remove the front service panel according to item, 2.1.2.
2. Remove the electrical box cover according to item, 2.1.12.
3. Remove all the field wiring at the terminal board for control between the indoor and outdoor units, and electrical wiring terminal board.
4. Disconnect the wiring connections and check to ensure that two stop valves are open.

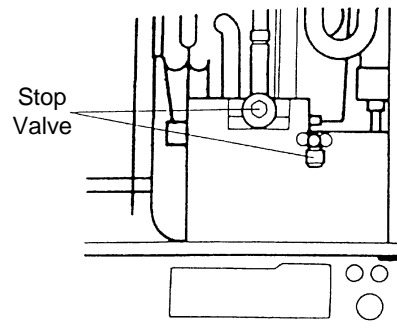
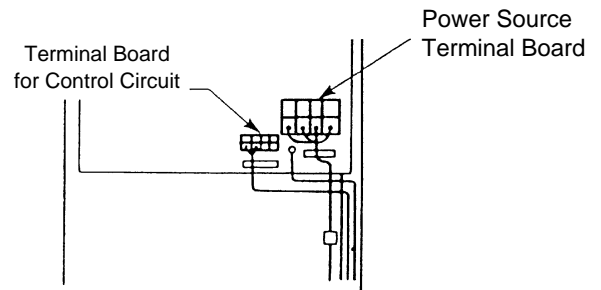

5. Disconnect the following to remove the reversing valve.
 - a. Brazing Portion between Reversing Valve and Discharge Pipe
 - b. Brazing Portion of the Right and the Left Pipes of Three Pipes from the Reversing Valve.
 - c. Brazing Portion of the Center Pipe of Three Pipes from the Reversing Valve.

NOTE:

Cover the reversing valve with wet cloth to protect it from excessively high temperature by a burner.

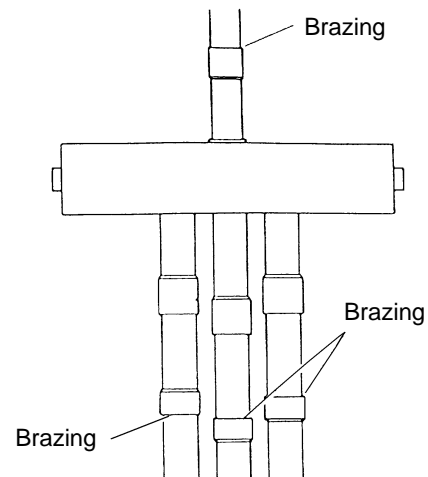

! **WARNING:** TURN OFF all power source switches

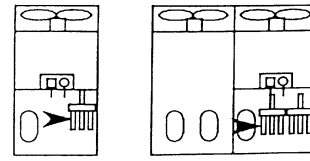

RAS-5FSG, 5FS3,
RAS-8FSG, 8FS3,
RAS-10FSG, 10FS3

RAS-16FSG, 16FS3
RAS-20FSG, 20FS3

2.1.12 REMOVING ELECTRICAL COMPONENTS

! **DANGER**

DO NOT touch the electrical parts when the LED3(Red) on the SNUBBER PCB(PCB5) or the LED2(Red) on the Inverter PCB(PCB3) is lit, since the voltage is higher than 50V.

! **WARNING**

- When replacing transistor module (IPM) and diode module (DM) on heat radiation fins, spread silicone grease (made by Shinetsu chemical Co., KS61) lightly over the surface touching fins.
- Identify terminals Nos. with the mark band Nos. when reassembling. If incorrectly connected, malfunctions or damages of electric components will occur.
- Correctly insert two wires of U and V phases for the power cable of Inv. Comp. into the current sensor, CTU and CTV on PCB3. Connect the U phase of the power cable and U phase of the current sensor as a combination, and the V phase of the power cable and V phase of the current sensor as a combination respectively. If incorrectly connected, malfunction or damages will occur.
- Do not clamp electrical wires between a mounting electric component and plates or electric parts when a PCB is remounted.
- Screws, bushes and collars are used to fix the inverter PCB. Check to ensure that the bushes and collars are used when fixing the inverter PCB again. If not used, it may cause malfunction.
- In the case that the control PCB is replaced, set all the dip switch at the same position as the original ones were. If not set, malfunction may occur.
- Do not apply a strong force to electric components and PCBs to avoid damages.

■ Removing PCBs

- Remove two screws fixing the electrical box cover and remove the electrical box cover.
- Disconnect the connector connected to the PCB and clamp the middle portion of the holder by pinchers and pull it out. Pull the PCB by applying a force by finger to the portion near the holder of the PCB from the rear side.
- Replacing Inverter PCB (PCB3)
After removing four (4) M3 screws and remove bushes and collars from the PCB. When remounting, firmly mount the bushes and collars.

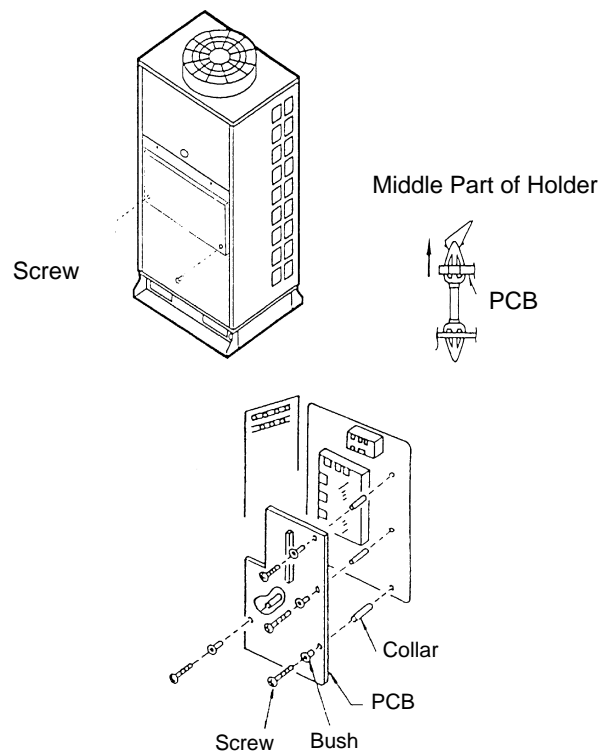

⚠ WARNING: TURN OFF all power source switches

■ Others

Other parts located at the rear side of PCB mounting plate and AC chopper mounting plate should be replaced as follows.

- Remove two (2) screws fixing the mounting plate for the PCB and turn the plate towards the front side.
- Remove two (2) screws fixing the mounting plate for the AC chopper and turn the plate toward the front side.

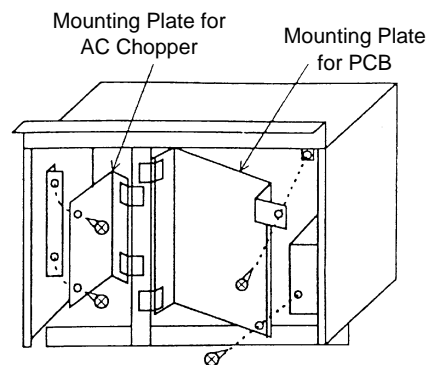

■ Removing Magnetic Contactor for Inverter Compressor

- Remove two (2) screws fixing the mounting plate for PCB and turn the plate towards the front side.
- Remove two (2) screws fixing the magnetic contactor for inverter compressor.

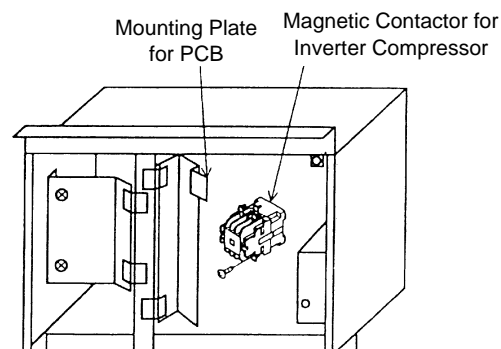
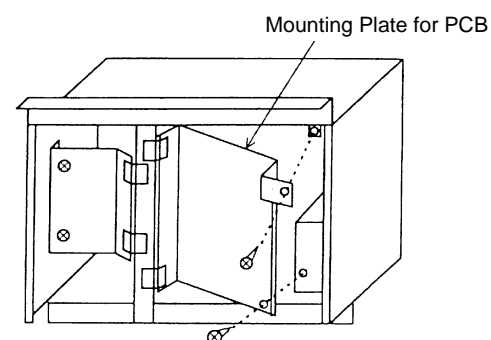

2.2 IN-THE-CEILING TYPE (Models: RPI-0.8FSGE, RPI-1.0FSGE, RPI1.5FSGE, RPI-2.0FSGE, RPI-2.5FSGE, RPI-3.0FSGE, RPI-4.0FSGE and RPI-5.0FSGE)

2.2.1 REMOVING PRINTED CIRCUIT BOARD (PCB)

- Remove the screw (1 pc.) fixing the electrical box cover and remove the electrical box cover.
- Disconnect the connectors. Remove the PCB by holding the expanded part of the holders using long-nose pliers.

NOTE:

Do not touch electrical components on the PCB.
If a big force is applied to the PCB, it will be damaged.

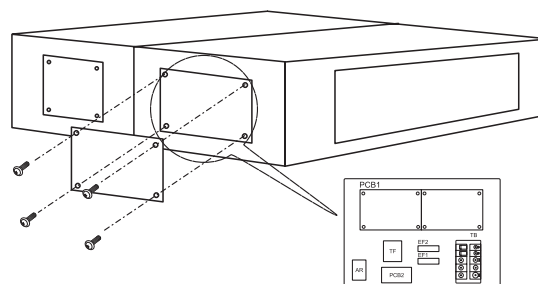

! **WARNING:** TURN OFF all power source switches

2.2.2 REMOVING INDOOR FAN MOTOR

1. Open bottom Service Access
2. Disconnect the Connector for the Motor and Capacitor
3. Remove the Fan Motor mounted on the fixing plate according to the process shown beside
4. Loosen the screw fixing each fan runner by a hexagon wrench
5. Remove the screws (4 pcs.) fixing each casings and pull out each casings
6. Remove the holding band for the motor and remove the motor carefully

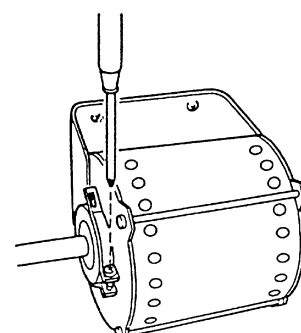
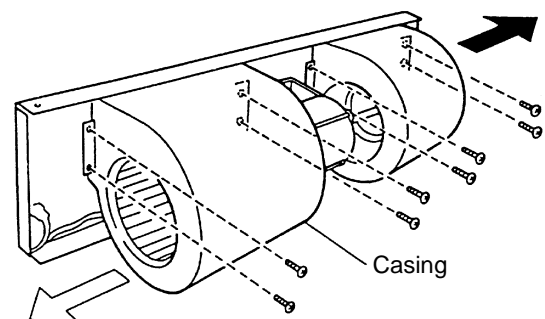
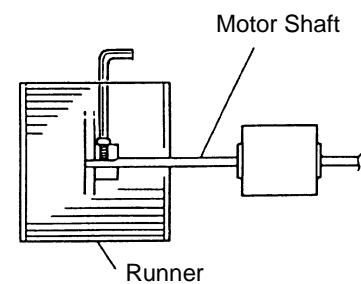
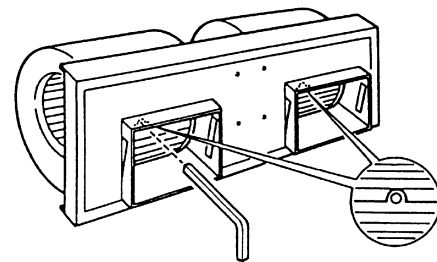
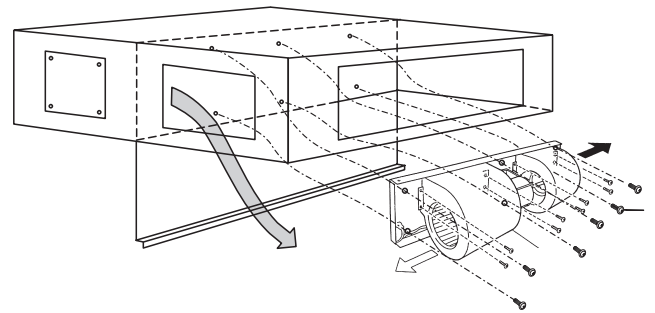
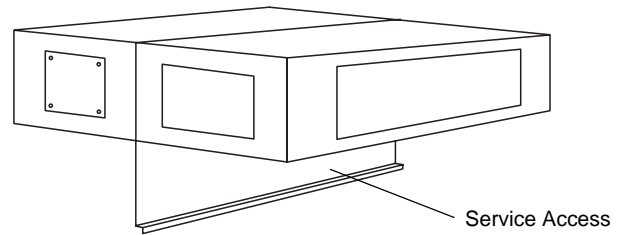

WARNING: TURN OFF all power source switches

2.2.3 REMOVING THERMISTORS FOR LIQUID PIPE AND GAS PIPE

1. Remove the screws (4 pcs.) fixing the service cover and remove the service cover.

2. Remove the CORK TAPE and pull out the thermistors after removing the fixing plate for the thermistor

NOTE:

Carefully handle the float switch.

Do not drop it on the floor. If dropped, malfunction may occur.

When mounting, do not use a motor-driven screwdriver.

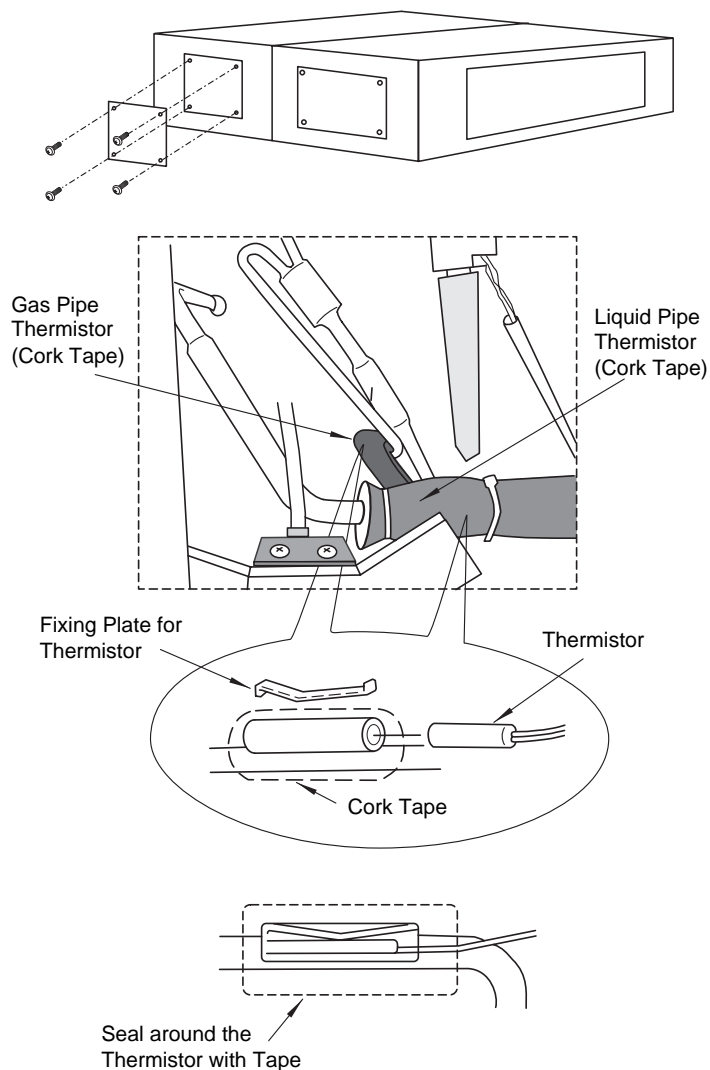

2.2.4 REMOVING FLOAT SWITCH

1. Remove the screws (4 pcs.) fixing the service cover and remove the service cover

2. Remove the screws (2 pcs.) of the plate fixing the float switch and remove the float switch

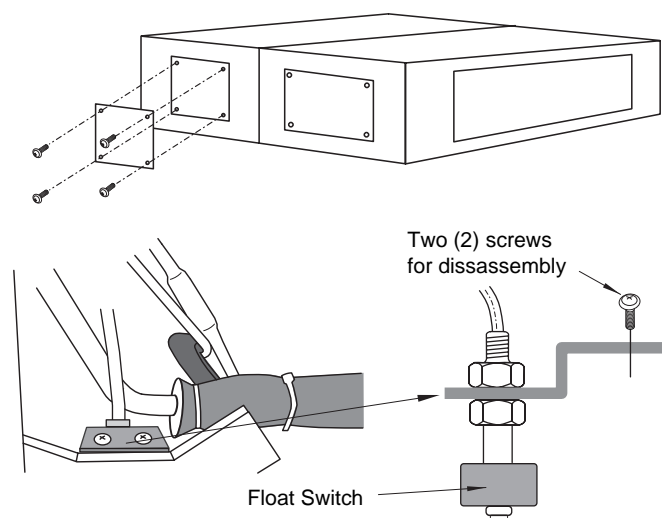

2.3 4-Way Cassette Type

2.3.1 REMOVING LONG LIFE FILTER

1. The long life filter is located inside of the intake air grille. Detach the filter after opening the intake air grille. By pushing the knob in the arrow mark direction, the intake air grille can be opened.
2. The filter can be removed from the intake air grille by supporting the lower side of the intake air grille and filter, and unhooking it from the extrusion part.

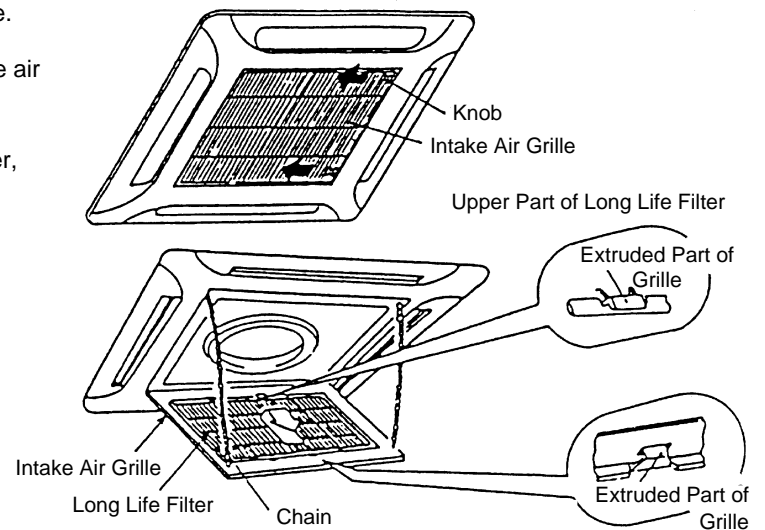

2.3.2 REMOVING INTAKE AIR GRILLE

1. By lifting the intake air grille at an angle of approximately 30° and releasing its chain, the intake air grille can be removed by holding it upwards and then towards you. If the chain is released and the angle is 90°, the intake air grille can not be removed.

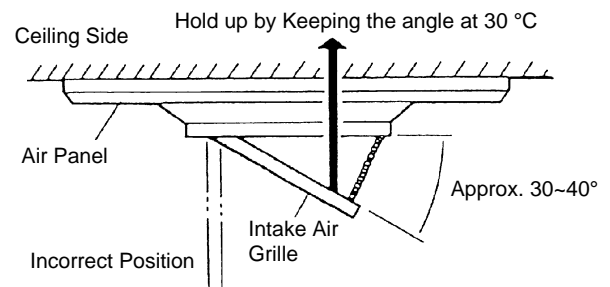

2.3.3 REMOVING ELECTRICAL BOX COVER

1. By opening the intake air grille, the electrical box can be seen. Remove two (2) screws fixing the electrical box cover and remove the cover.

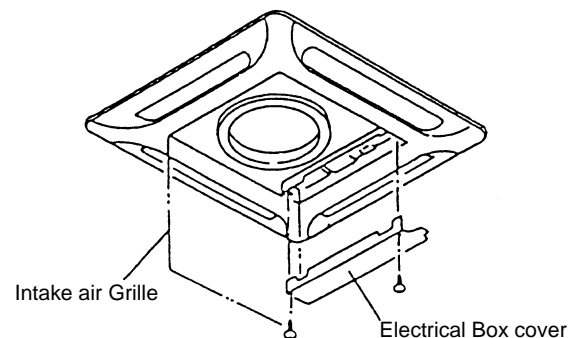

2.3.4 REMOVING OPTIONAL AIR PANEL

1. By opening the intake air grille, the electrical box can be seen.
Remove two (2) screws fixing the electrical box cover and remove the cover.
 - 1 Disconnect the connector (Red; 2 Pins) for the dew protection heater on the indoor PCB.
 - 2 Disconnect the connector (Red; 7 Pins) for the automatic louver motor on the indoor PCB.

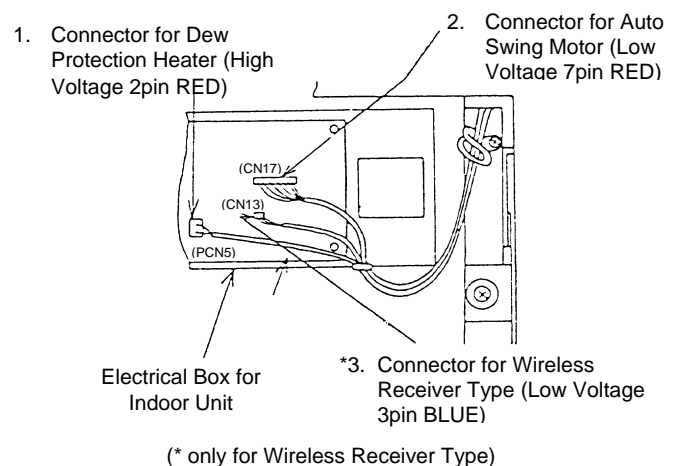

⚠ WARNING: TURN OFF all power source switches

2. Remove the intake air grille from the optional air panel. Remove four (4) screws fixing the optional air panel. (Remove the fixing screws by hooking on the hinge.) Remove the optional air panel after unhooking the hinge onto the hooks at the two positions near the drain pan.

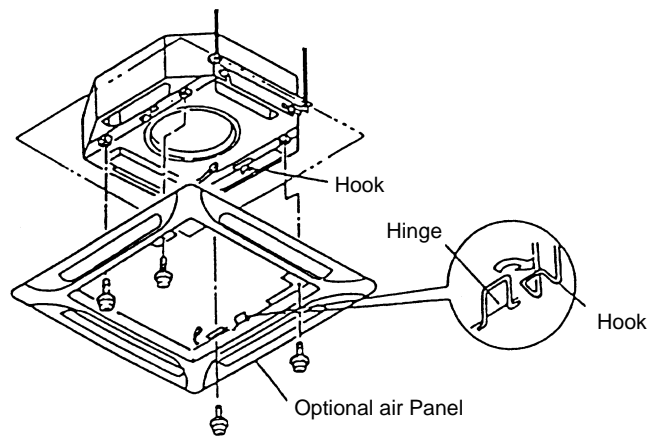

2.3.5 REMOVING TURBO FAN AND FAN MOTOR

1. Remove the intake air grille according to the item 2.3.2, "Removing Intake Air Grille".
2. Drawing Electrical Box
 - 1 Remove the discharge air thermistor from the PCB.
 - 2 Disconnect the connector of each lead wire.
 - 3 Remove two (2) fixing screws for the electrical box and pull the electrical box towards the front, then the electrical box will turn with an angle of approximately 90°

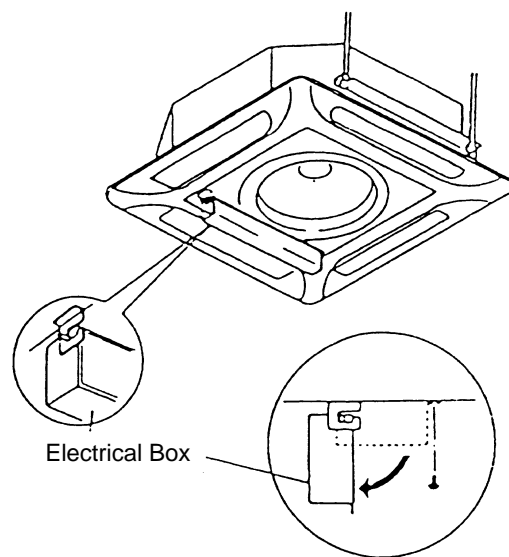

3. Removing Bell-Mouth
 - 1 Remove four (4) screws fixing the bell-mouth onto the drain pan and remove the bell-mouth.

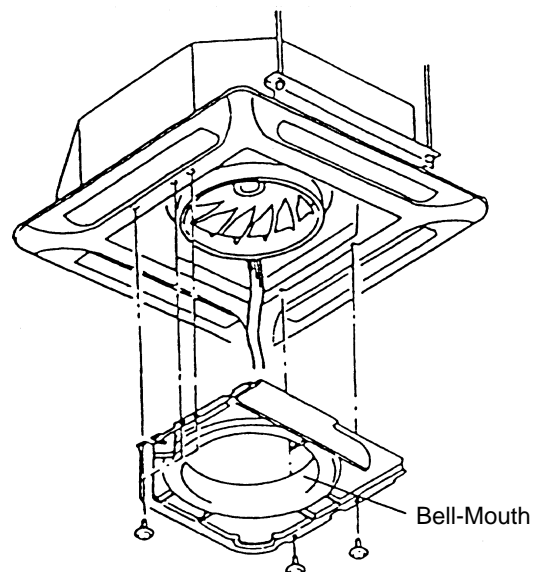

WARNING: TURN OFF all power source switches

4. Removing Turbo Fan and Fan Motor

The turbo fan can be removed after removing the fixing screws for the turbo fan, vibration absorbing rubber, special washers and flat washers.

- 1 Remove the wiring connector for the fan motor and the earth wire
- 2 Remove the motor after removing four (4) fixing screws.

NOTE:

Fix the turbo fan with a fixing torque of approximately 30kg-cm for each screw after mounting the vibration absorbing rubber onto the turbo fan when assembling.

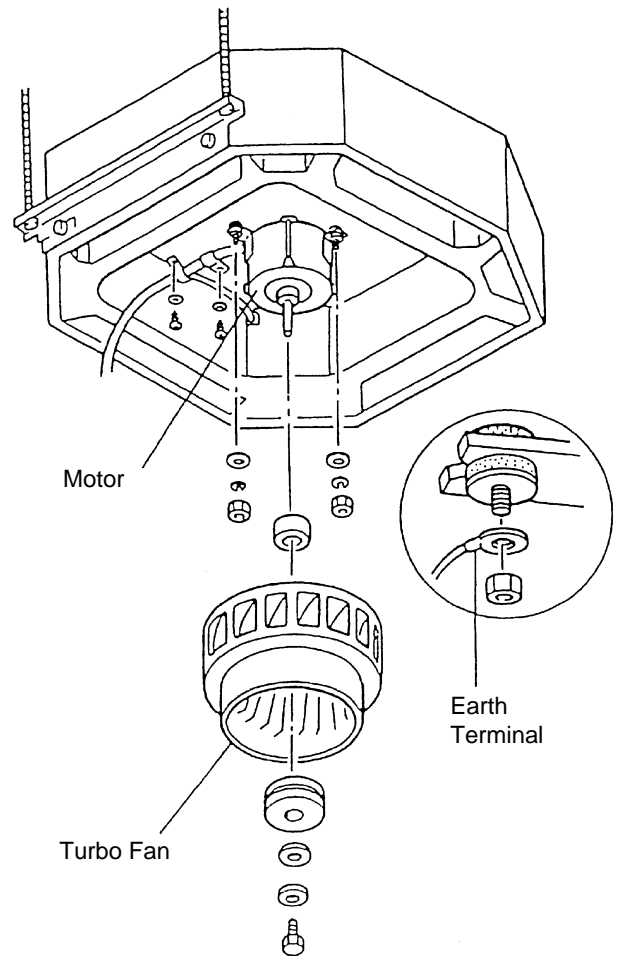

2.3.6 REMOVING PRINTED CIRCUIT BOARD (PCB)

1. Remove the intake air grille according to the item 2.3.2 "Removing Intake Air Grille".
2. Remove the electrical box cover according to the item 2.3.3, "Removing Electrical Box Cover".
3. There is a printed circuit boards (PCB) in the electrical box. Disconnect the connectors. The PCB is supported by six (6) holders. Remove the PCB by holding the expanded part of the holders using long-nose pliers.

NOTE:

Do not touch electrical components on the PCB.
If big force is applied to the PCB, it will be faulty.

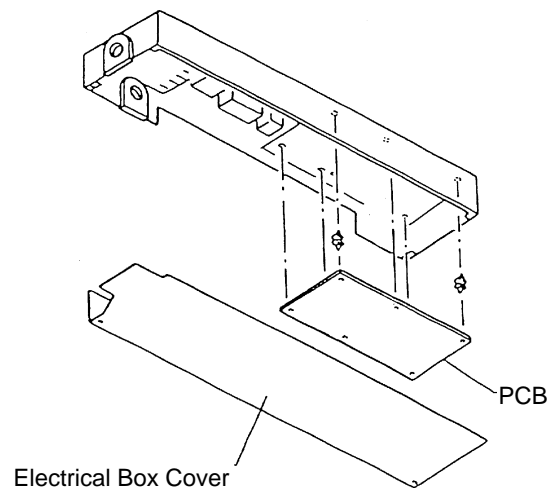

⚠ WARNING: TURN OFF all power source switches

2.3.7 REMOVING FLOAT SWITCH

1. Remove the intake air grille according to the item 2.3.2, "Removing Intake Air Grille".
2. Remove the bell-mouth and turbo fan according to the item 2.3.5, "Removing Turbo Fan and Fan Motor".
3. Remove the service access cover after removing three (3) fixing screws near the pipes inside of the indoor unit.

4. Removing Float Switch

Remove the float switch after removing one (1) fixing screw from the fixing plate of the heat exchanger

NOTE:

Carefully handle the float switch. Do not drop it on the floor. If dropped, malfunction may occur. When mounting, do not use a motor-driven screwdriver.

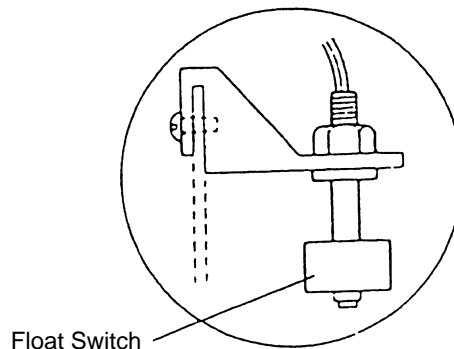
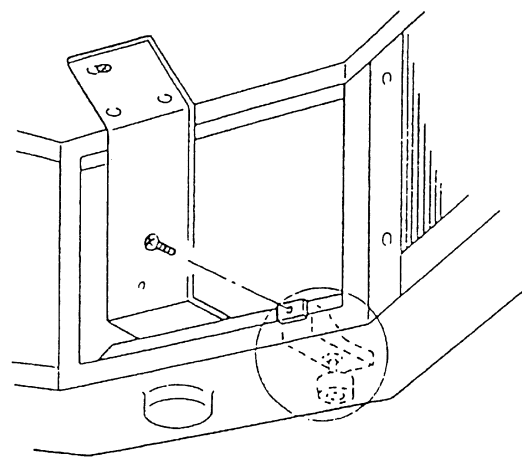
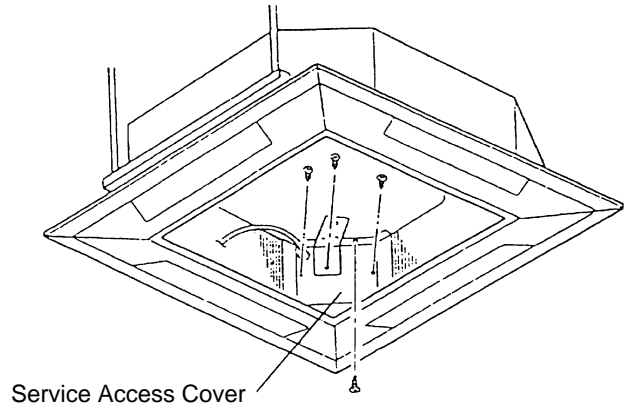

2.3.8 REMOVING DRAIN-UP MECHANISM

1. Remove the service access cover near the pipes according to the item 2.3.7, "Removing Float Switch".
2. Remove two (2) screws(A) fixing the fixing plate for the drain-up pump after removing the wiring connector. Loosen the fixing screw(B), remove the fixing plate from the fixing screw(B) and pull out the drain-up mechanism.
3. Firstly support the drain-up mechanism by hand so as not to drop. Remove the hose band from the drain hose, disconnect the drain hose, and then remove the drain-up mechanism.

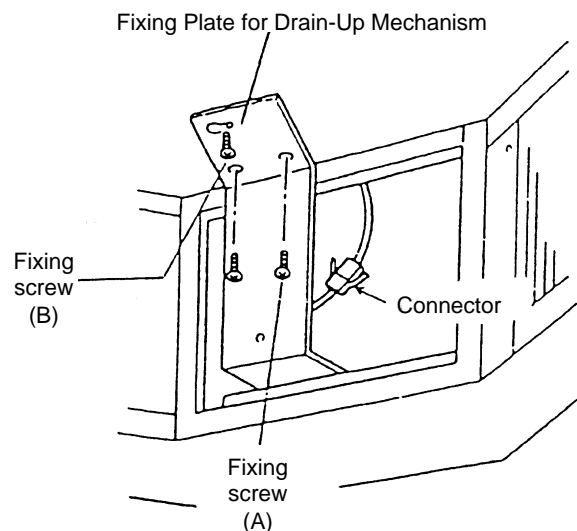

WARNING: TURN OFF all power source switches

NOTE:

Do not remove the screw (B).
If removed, the drain-up mechanism will drop

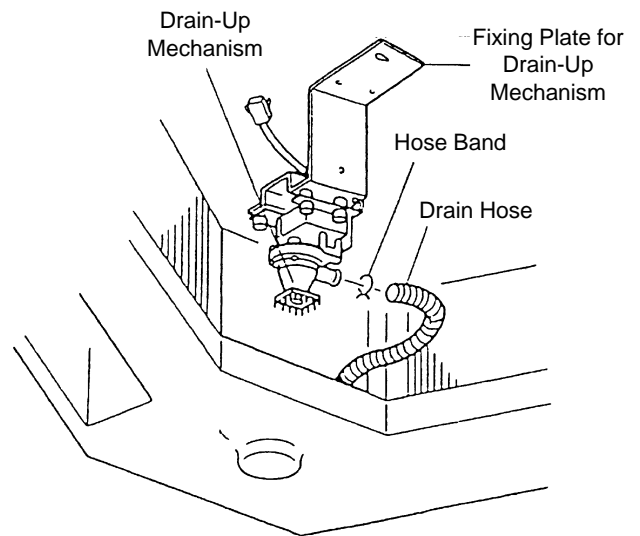

2.3.9 REMOVING DRAIN PAN

1. Remove the optional air panel according to the item, 2.3.4, "Removing Optional Air Panel".
2. Disconnect the connectors between indoor unit and outdoor unit, and in the electrical box after opening the electrical box cover according to the item, 2.3.3, "Removing Electrical Box Cover".
3. Remove the bell-mouth according to No.3 of item, 2.3.5, "Removing Turbo Fan and Fan Motor".
4. Remove drain water.
5. Remove the drain pan after removing four (4) screws fixing the drain pan onto the indoor unit.

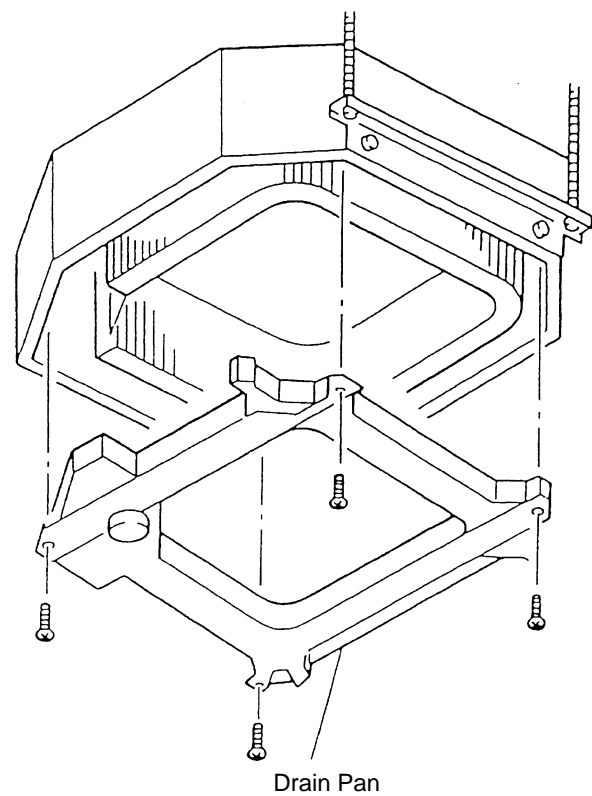

⚠ WARNING: TURN OFF all power source switches

2.3.10 REMOVING THERMISTORS FOR LIQUID PIPE AND GAS PIPE

1. Remove the optional air panel according to the item 2.3.4, "Removing Optional Air Panel".
2. Remove the bell-mouth according to No.3 of item 2.3.5, "Removing Turbo Fan and Fan Motor".
3. Remove the drain pan according to the item 2.3.9, "Removing Drain Pan".
4. Remove the CORK TAPE, pull out the fixing plate for the thermistor from the gas pipe, where the thermistor is located, and then pull out the thermistor.

NOTE:

Fix the fixing plate as shown in the Figure 2.

Figure 1

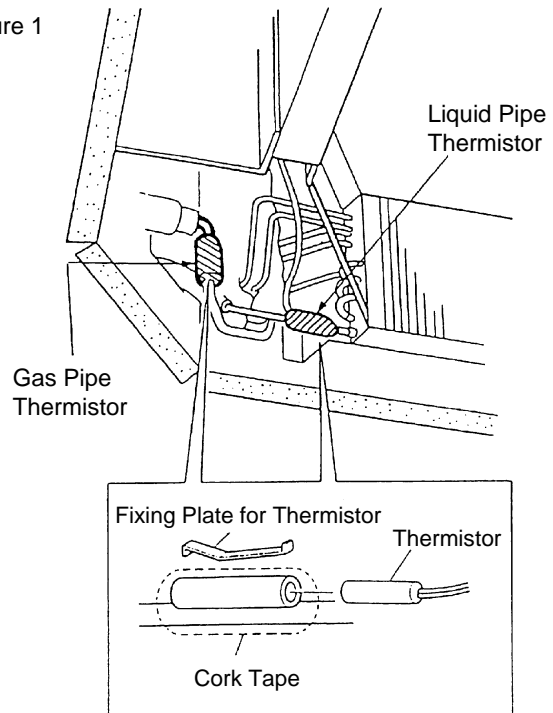
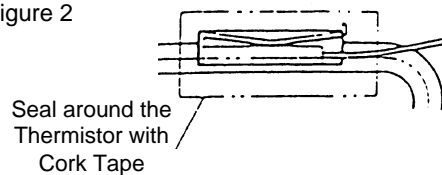

Figure 2



2.3.11 REMOVING EXPANSION VALVE COIL

1. Remove the optional air panel according to the item 2.3.4, "Removing Optional Air Panel".
2. Remove the bell-mouth according to No.3 of item 2.3.5, "Removing Turbo Fan and Fan Motor".
3. Remove the drain pan according to the item 2.3.9, "Removing Drain Pan".
4. Prepare two (2) spanners. Hold the part of the valve body with one spanner and loosen the lock nut with another spanner by turning the lock nut counterclockwise.

NOTE:

Do not hold the motor part when loosening the lock nut by spanner. The base of the drive part may turn idle and be broken.

5. Turn the lock nut by a few turn, and the drive part is separated from the screw and can be removed.
6. Prepare the new drive part for replacement (service part) with the position of the driver (drive screw) already adjusted.

NOTE:

During replacement work, pay attention to the separation part and prevent the dust, foreign particle, etc. from entering into the separation part. (The exposed part by separation is the mechanical part of the valve.)
Do not hurt the junction part of the valve with the tools.

7. Put the drive part onto the valve body, hold them with their axes matching and attach the lock nut to the screw part of the valve body.

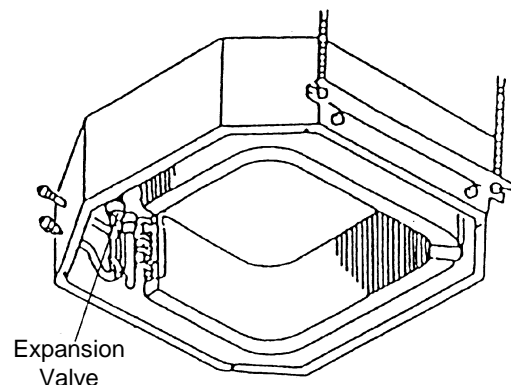

WARNING: TURN OFF all power source switches

- Tighten the lock nut with spanner after tightening lightly by hand. The tightening torque shall be within the range of 12Nm(120kg-cm) ~15Nm(150kg-cm).

NOTE:

Do not apply the strong forces such as the rotating torque and the bending load to the motor by holding the motor by hand when tightening the lock nut.

The direction of the eccentric part of the motor is assembled as the eccentric part of Although the motor is directed toward the counterdirection of the fittings for piping at the valve body, the alteration of this direction do not affect the open/close function of the valve. Therefore, the adjustment of the direction of the motor part is not required if the position of the motor is moved toward the rotating direction after replacement as shown in Figure 2.

- After completion of the replacement, attach the electronic expansion valve in the reverse procedures for removing.

Fig. 1. Expansion Valve

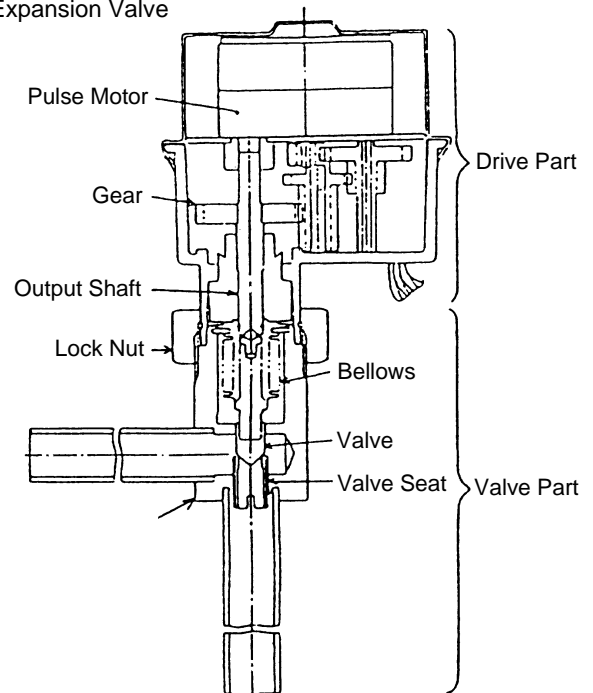
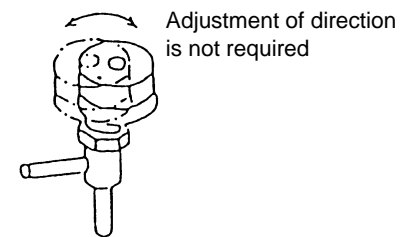
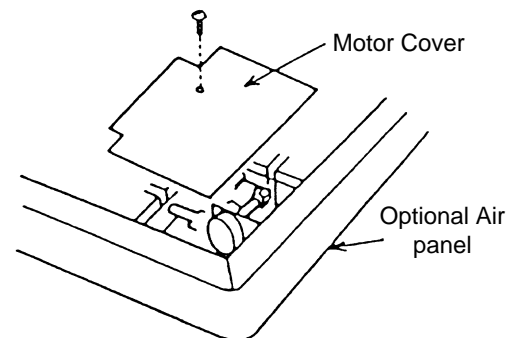

Fig. 2. Direction of Drive Part



2.3.12 REMOVING AUTOMATIC LOUVER MOTOR

- Remove the optional air panel according to the item 2.3.4, "Removing Optional Air Panel".
- Remove the motor cover after removing two (2) screws fixing the motor cover for the automatic louver motor.



- Disconnect all the connectors connected to the motor.

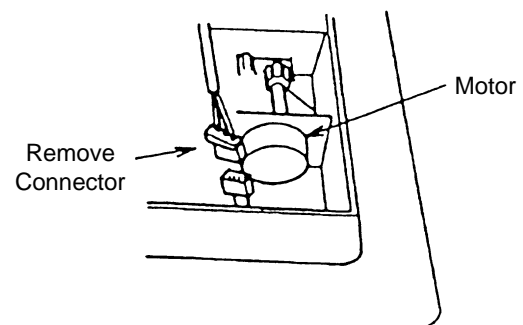

⚠ WARNING: TURN OFF all power source switches

- Remove the motor with the fixing plate after removing three (3) fixing screws.

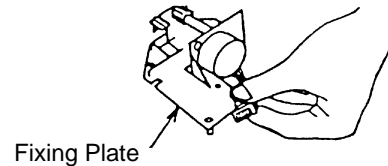
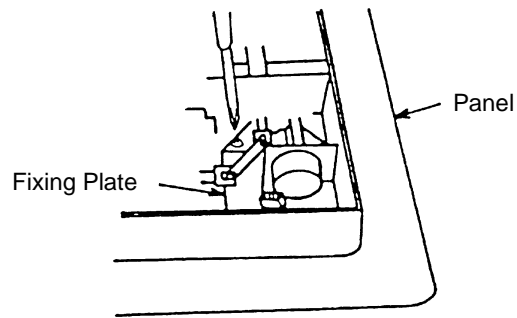

- Remove the motor from the fixing plate after removing two (2) fixing screws, and remove the pinion from the motor after removing one (1) screw.

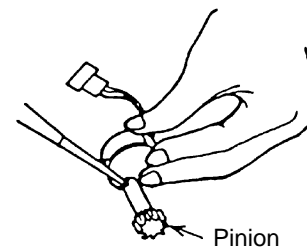
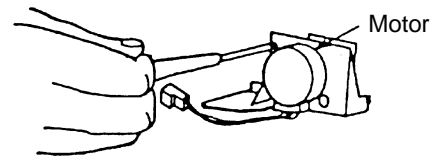

2.4 2-WAY-CASSETTE TYPE

2.4.1 REMOVING LONG LIFE FILTER

- The long life filter is located inside of the intake air grille. The intake air grille can be opened by pushing the knobs as shown below.
- Remove the long life filter after opening the intake air grille. The long life filter can be removed from the intake air panel by supporting the lower side of the intake air grille, lifting the long life filter, and unhooking it from the extrusion part.

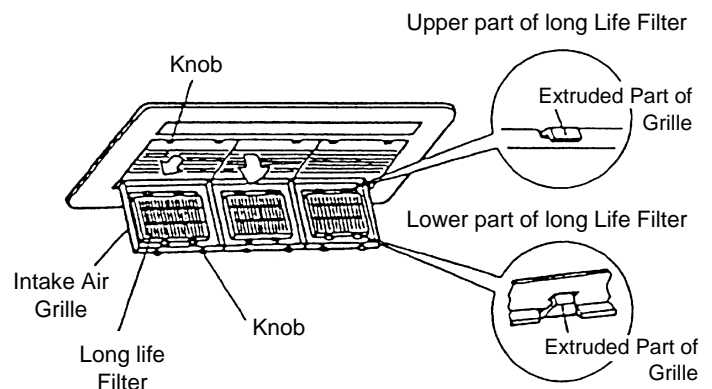

2.4.2 REMOVING INTAKE AIR GRILLE

- Open the intake air grille at an angle of approximately 30 ~ 45°, lift it upwards with inclined, draw it towards the front side, and the intake air grille can be removed.

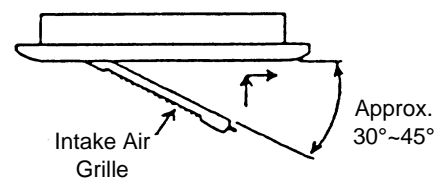

WARNING: TURN OFF all power source switches

2.4.3 REMOVING ELECTRICAL BOX COVER

1. By opening the intake air grille, the electrical box can be seen. Remove one (1) screw fixing the electrical box cover and remove the cover.

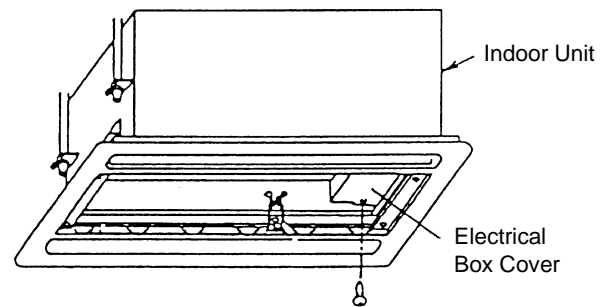

2.4.4 REMOVING OPTIONAL AIR PANEL

1. Disconnect the wiring connectors after opening the air intake grille and electrical box cover.

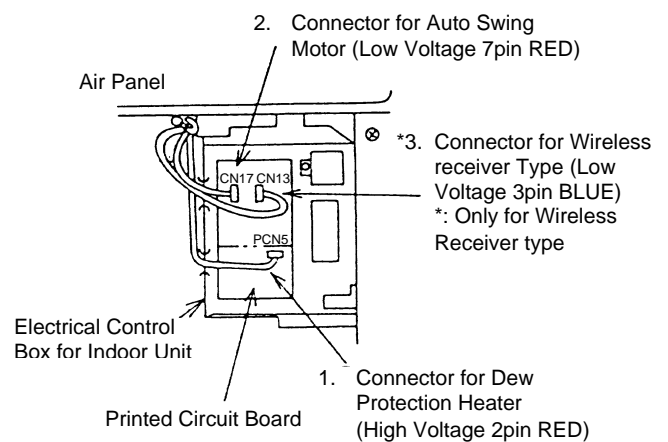

2. Remove screws (P-15DWA(H): 4pcs., P-23DWA(H) and P-46DWA(H): 6pcs.) fixing the optional air panel onto the indoor unit.
3. Remove the optional air panel by unhooking the hook of the suspension bracket.

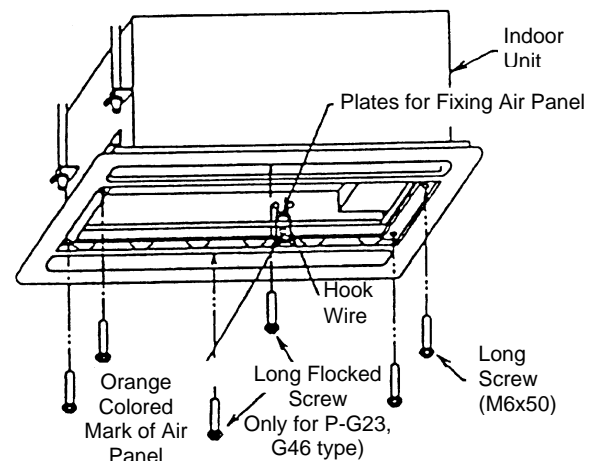

⚠ WARNING: TURN OFF all power source switches

2.4.5 REMOVING FAN MOTOR

1. Remove the intake air grille according to the item, 2.4.2, "Removing Optional Air Panel".
2. Disconnect the connector for the fan motor.
3. Remove the fan motor mounted on the fixing plate according to the procedures shown beside.

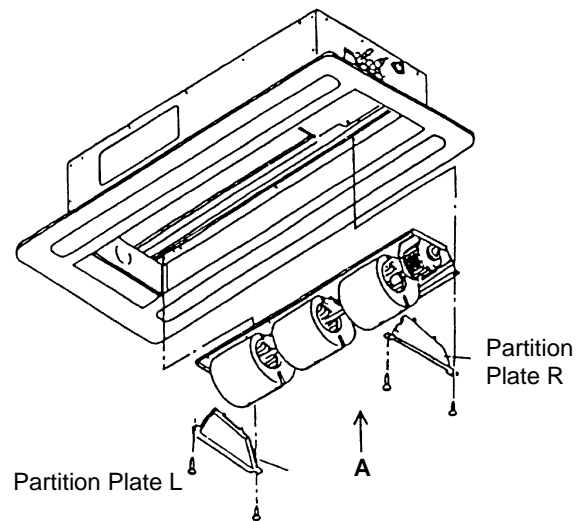

In Case of 1.0 and 1.5HP

1. Remove the partition plate R and the partition plate L.
2. Remove the screw (B) fixing the motor and loosen the fixing screw (A)
3. slide the motor toward the (P) direction and remove the motor

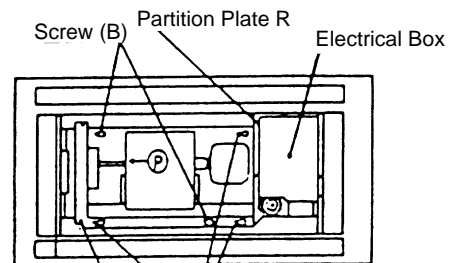

Partition Plate L Screw (A)

In Case of 2.0~5.0HP

1. Remove the partition plate R and the partition plate L.
2. Remove the screws (B) and (C) fixing the motor and loosen the fixing screw (A)
3. Slide the motor toward the (P) direction and remove the motor

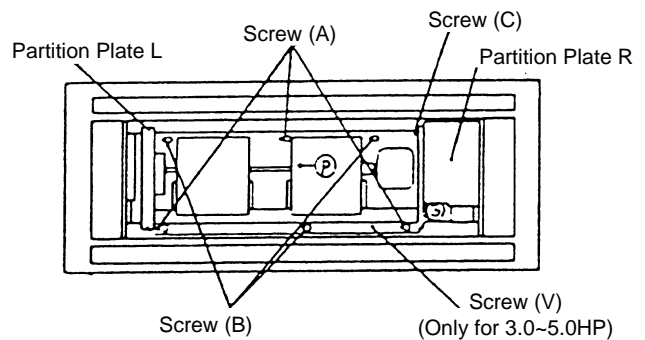

4. Remove the casing by pushing four (4) extruded parts at the lower part of the casing, which consists of two parts.

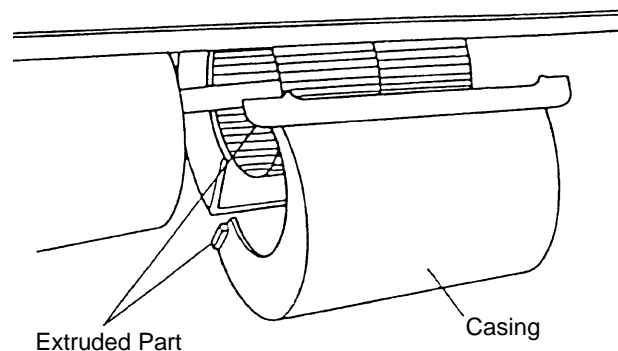

! WARNING: TURN OFF all power source switches

5. Loosen the screw of the coupling by a hexagon wrench.

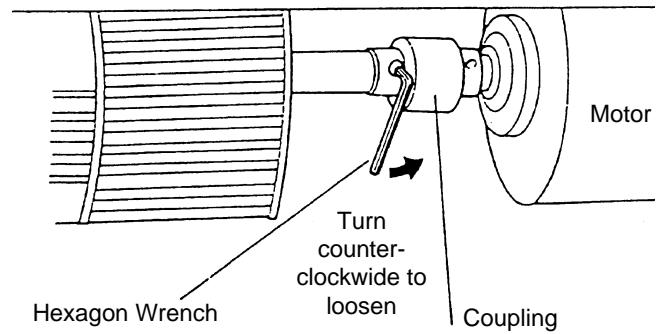

6. Remove the motor, after removing the fixing band for the motor. Perform this work by supporting the motor by hand.

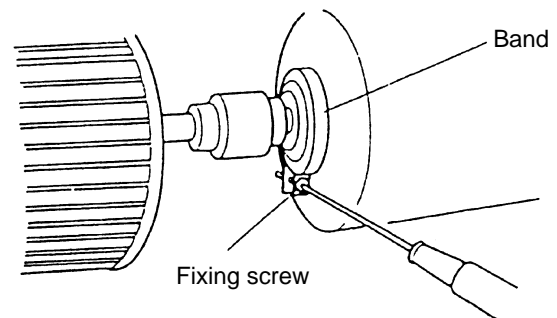

2.4.6 REMOVING BEARING

1. Remove the optional air panel according to the item 2.4.4, "Removing Optional Air Panel".
2. Loosen two (2) fixing screws fixing the bearings and shaft by a hexagon wrench.
3. Remove the bearing.

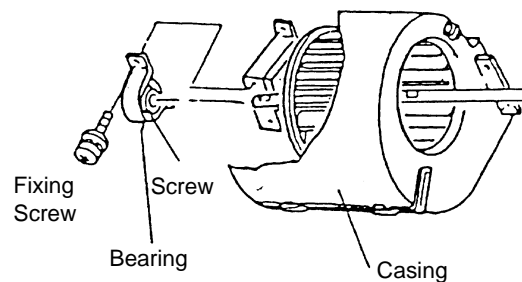

2.4.7 REMOVING COUPLING

1. Remove the optional air panel according to the item 2.4.4, "Removing Optional Air Panel".
2. Remove the fan assembly according to the item 2.4.5, "Removing Fan Motor".
3. Remove the bearing according to the item 2.4.6, "Removing Bearing".
4. Remove the coupling and the turbo fan after removing the fan assembly.

2.4.8 REMOVING PRINTED CIRCUIT BOARD (PCB)

1. Remove the intake air grille according to the item 2.4.2, "Removing Intake Air Grille".
2. Remove the electrical box cover according to the item 2.4.3, "Removing Electrical Box Cover".
3. Pull out the PCB holders (Holder A: 6pcs., Holder B: 1pc.) by pinching the expanded part of the holders by long-nose plier and remove the PCB.

NOTE:

Do not touch electrical components on the PCB.
Do not apply big force to the PCB. If applied, it will be faulty.

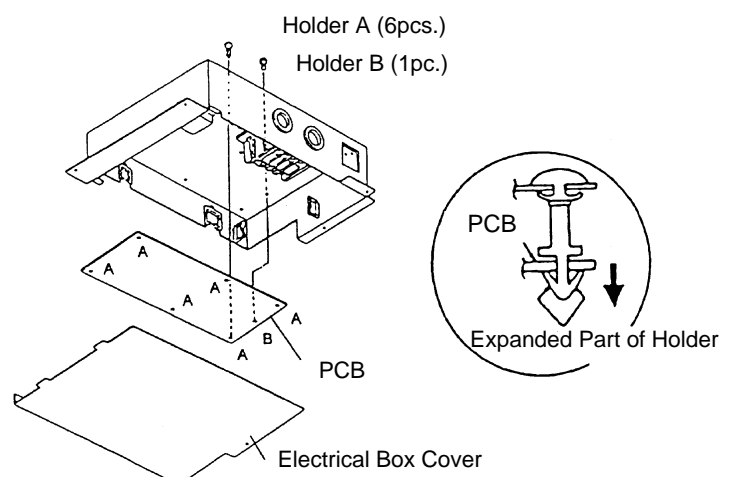

⚠ WARNING: TURN OFF all power source switches

2.4.9 REMOVING FLOAT SWITCH

1. Remove the optional air panel according to the item 2.4.4, "Removing Optional Air Panel".
2. Remove the fan assembly according to the item 2.4.5, "Removing Fan Motor".
3. Remove the float switch after removing one (1) screw fixing the fixing plate for float switch onto the fixing plate for the heat exchanger.

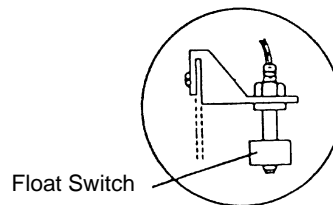
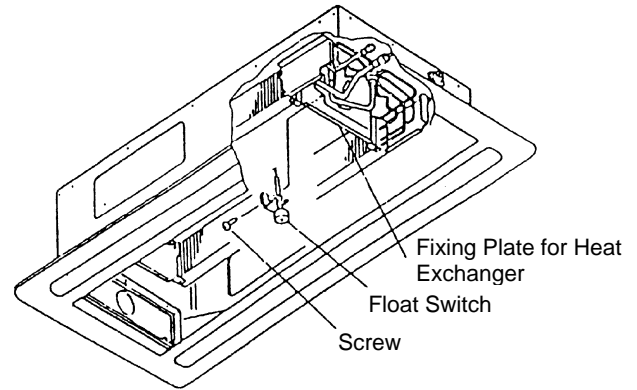

2.4.10 REMOVING DRAIN-UP MECHANISM

1. Remove the fan assembly according to the item 2.4.5, "Removing Fan Motor".
2. Disconnect the wiring connectors.
The drain pump can be removed by sliding the drain pump in the arrow direction after removing the fixing screw (A) and loosening the fixing screw (B).
Remove the hose band of the drain hose by holding the drain-up mechanism not to fall, remove the drain hose from the drain-up mechanism and remove the drain-up mechanism with the fixing plate.

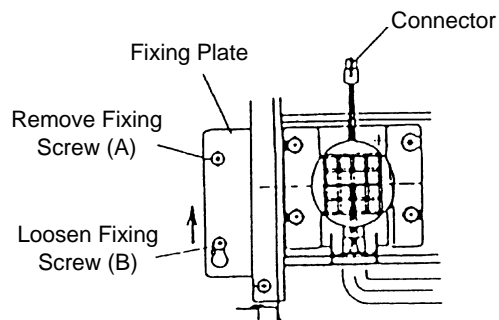
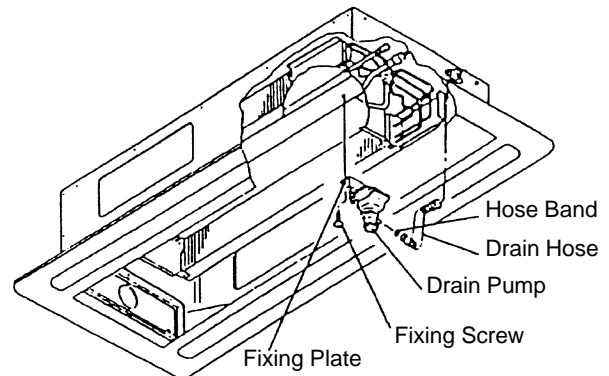

2.4.11 REMOVING DRAIN PAN

1. Remove the intake air grille according to the item 2.4.2, "Removing Intake Air Grille".
2. Remove the fan assembly according to the item 2.4.5, "Removing Fan Motor".
3. Remove the electrical box cover according to the item 2.4.3, "Removing Electrical Box Cover".
4. Removing Electrical Box
 - 1 Remove the thermistor at the air outlet and the air inlet.
 - 2 Disconnect the connectors of each lead wire.
 - 3 Remove three screws fixing the electrical box and hang the electrical box by the bunched wires

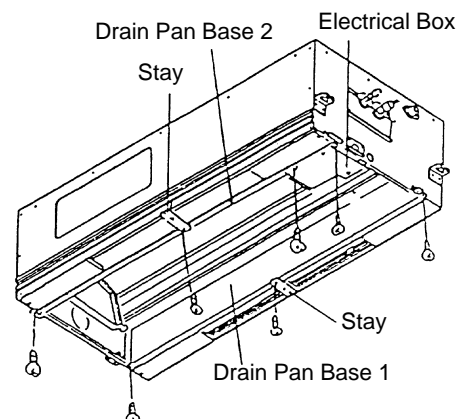

! WARNING: TURN OFF all power source switches

- Pull out the rubber plug and drain the water left in the drain pan. Prick the drain hole with a pencil, etc., to check to ensure that the drain hole is not clogged.
- Remove the screws fixing the drain piping pan base 1, 2 and the stay
- Remove the drain pan by sliding in the arrow direction and drawing out in a downward direction after loosening two (2) screws fixing the drain pan at both sides of the support plate.

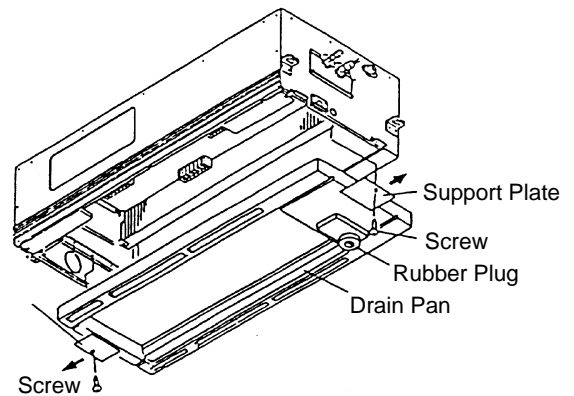

2.4.12 REMOVING THERMISTORS FOR LIQUID AND GAS PIPES

- Remove the optional air panel according to the item 2.4.4, "Removing Optional Air Panel".
- Remove the fan assembly according to the item 2.4.5, "Removing Fan Motor".
- Remove the drain pan according to the item 2.4.11, "Removing Drain Pan".
- Remove the CORK TAPE (for gas pipe) or the butyl sheet (for liquid pipe) fixing the thermistors, remove the thermo clip for the the thermistors from the pipes and remove the thermistors.

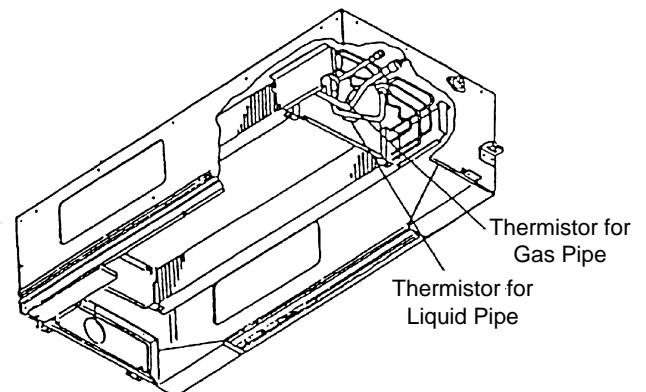
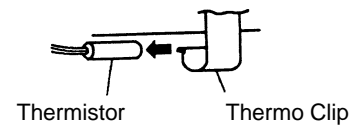

2.4.13 REMOVING ELECTRONIC EXPANSION VALVE COIL

- Remove the optional air panel according to the item 2.4.4 "Removing Optional Air Panel".
- Remove the fan assembly according to the item 2.4.5 "Removing Fan Motor".
- Remove the drain pan according to the item 2.4.11 "Removing Drain Pan".
- Refer to the item 2.3.11 "Removing Expansion Valve Coil" in page 2-20 and 21 for the procedures of removing electronic expansion valve coil

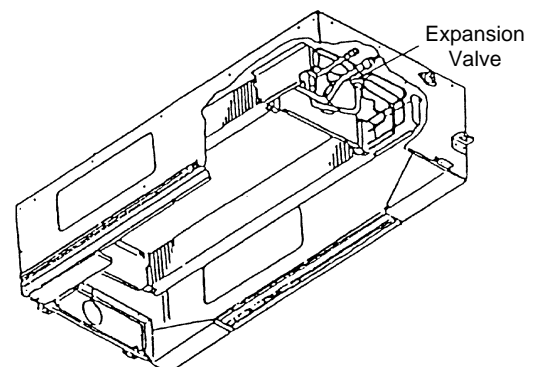

⚠ WARNING: TURN OFF all power source switches

2.4.14 REMOVING MOTOR FOR AUTOMATIC LOUVER

1. Remove the optional air panel according to the item 2.4.4, "Removing Optional Air Panel".
2. Remove the motor cover at the piping side after removing two (2) fixing screws.
3. Remove three (3) screws fixing the motor assembly and remove two (2) stoppers by lifting up the motor assembly in the arrow direction by hand. The motor assembly can be removed from the optional air panel by removing the connectors for wiring.
4. Remove one (1) screw fixing the crank and cut the plastic tie fixing the motor cord.
5. Remove the motor after removing two fixing screws.

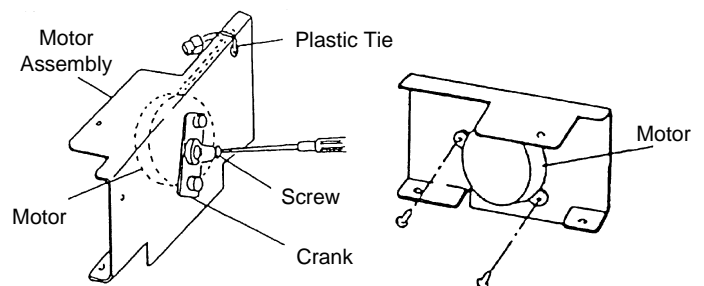
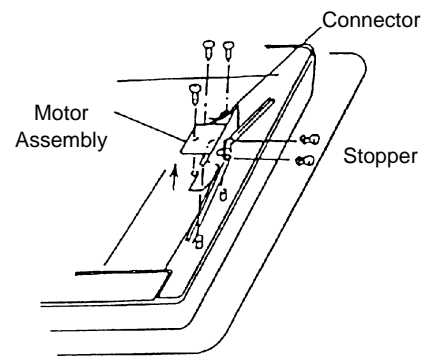
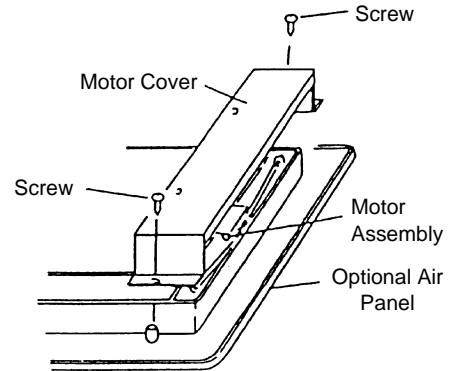

2.5 WALL TYPE

2.5.1 REMOVING AIR FILTER

1. Press two (2) portions (right and left) of the air intake grille as shown beside.
2. Slowly pull the lower side of the air intake grille toward the front side.

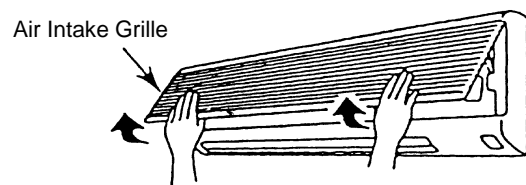
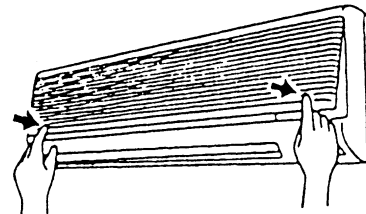

! **WARNING:** TURN OFF all power source switches

- Lift up the air filter, detach the hooks and draw the air filter downward

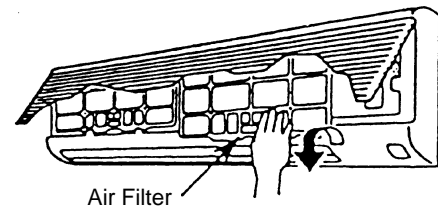

2.5.2 REMOVING FRONT PANEL

- Press the "PUSH" marks at both ends of the front panel and open the suction grille by pulling toward the front side.
- Remove one screw (1) at the center of the front panel. After removing the screw, close the front panel once.
- Remove three (3) bushes at the louver part of the air outlet and remove three screws.
- Hold both sides of the front panel, pull the front panel toward the front side slowly and lift up the front panel with paying attention not to touch the louver at the air outlet.
- Lift up the front panel slightly, the three hooks at the upper part of the front panel are detached from the holes of the unit body and the front panel can be removed toward the front side.

NOTE:

DO NOT hit the front panel when removing the front panel. It may break the unit body.

- For attaching the front panel, attach the front panel at the air outlet side firstly, and attach three (3) hooks at the upper part of the front panel.
- Open the front panel as the procedure (1), and fix the screw (1 piece) at the center of the front panel.
- There are three hooks at the inner side of the front panel. Press the hook part from the front side and check to ensure that there is no gap between the front panel and the unit body.

NOTE:

If the gap exists between the front panel and the air outlet, it may cause air leakage and dewing may occur at the front panel and the dew may drop.

- After attaching the front panel, tighten three (3) screws at the lower part of the air outlet and cover them with the bushes.

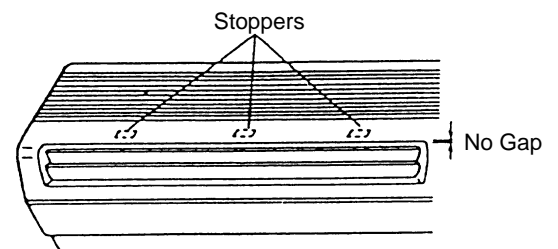
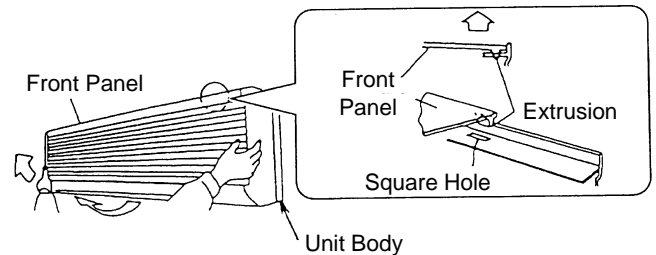
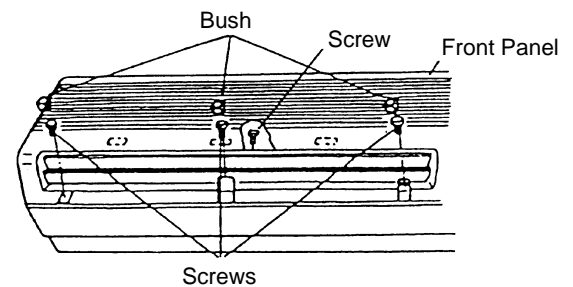

⚠ WARNING: TURN OFF all power source switches

2.5.3 REMOVING MOTOR FOR AUTOMATIC LOUVER

1. Remove the front panel according to the item 2.5.2, "Removing Front Panel".
2. Remove the electrical box according to the item 2.5.5, "Removing Electrical Box Cover".
3. Remove four (4) screws fixing the AS motor.
4. Draw out the AS motor horizontally, the AS motor is separated from the louver shaft.
5. For attaching the AS motor, insert the shaft of the AS motor into the D-cut hole of the louver, and perform the reverse procedures for removing AS motor.

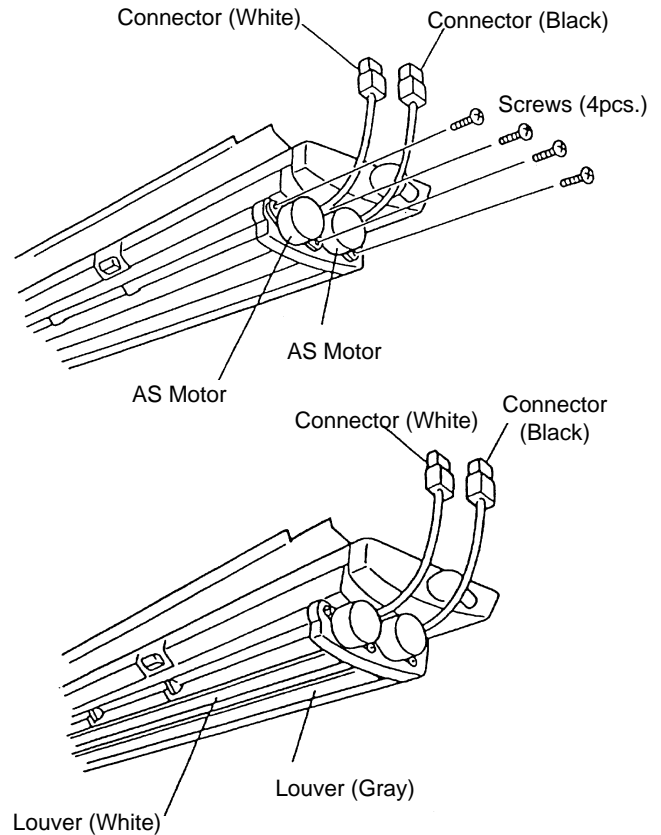

2.5.4 REMOVING THERMISTORS FOR LIQUID PIPE, GAS PIPE, DISCHARGE AIR AND SUCTION AIR

1. Remove the front panel according to the item 2.5.2, "Removing Front Panel".
2. Remove the electrical box according to the item 2.5.5, "Removing Electrical Box".
3. Removing Thermistor for Liquid Pipe
Remove the butyl sheet protecting the thermistor for liquid pipe and remove the thermistor from the holder.
4. Removing Thermistor for Gas Pipe
Remove the piping insulation protecting the thermistor for gas pipe, by cutting the plastic tie and surrounding tapes and remove the thermistor from the holder.

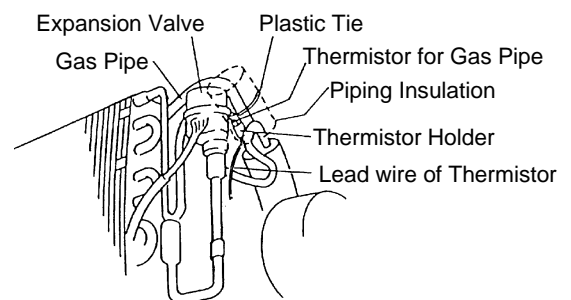
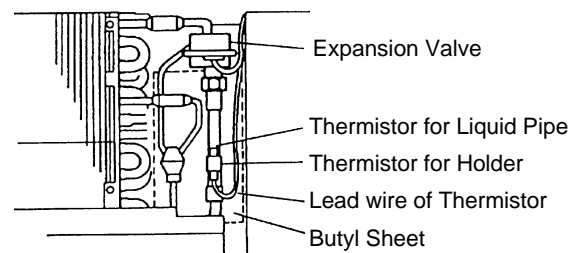

WARNING: TURN OFF all power source switches

5. Removing Thermistor for Discharge Air
Remove the thermistor for discharge air from the holder of the vertical louver and the hook at the right side of the air outlet.

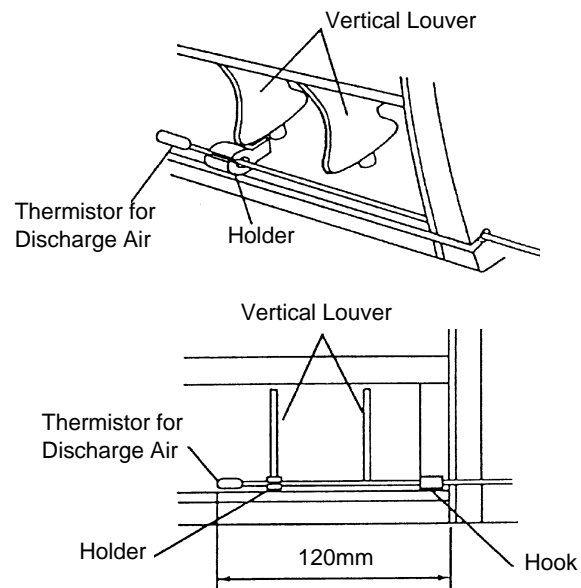

6. Removing Thermistor for Suction Air
Remove the thermistor for suction air by cutting the plastic tie fixing the thermistor onto the right side of the electrical box.

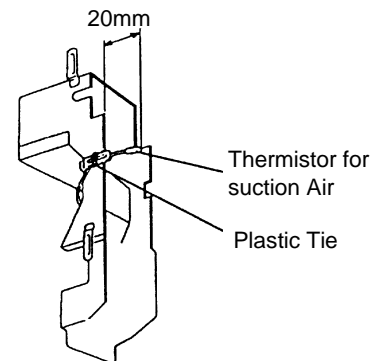

2.5.5 REMOVING ELECTRICAL BOX COVER

1. Remove the front panel according to the item 2.5.2, "Removing Front Panel".
2. Remove one screw (1) for the electrical box cover.
3. Remove the power source wiring and wiring connection between indoor unit and outdoor unit.

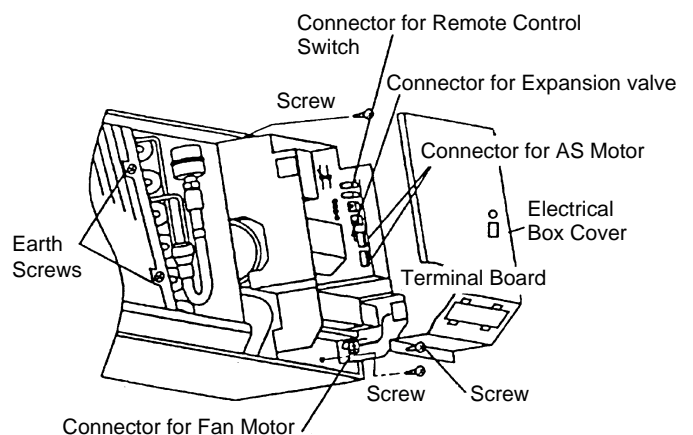

4. Remove lead wires for expansion valve, fan motor, thermistor for liquid pipe and gas pipe, AS motor (X 2) and remote control switch from the connectors. And also remove earth wires (x2) of the heat exchanger.
5. Remove the thermistor for discharge air from the holder fixed at the vertical louver of the air outlet.
6. Draw out the electrical box toward the front side after removing two (2) screws fixing the electrical box.
7. For attaching the electrical box, set the electrical box, connect the connectors and perform the reverse procedures for removing the electrical box.

⚠ WARNING: TURN OFF all power source switches

2.5.6 REMOVING INDOOR PCB

1. Remove the front panel according to the item 2.5.2, "Removing Front Panel".
2. Remove one screw (1) for the electrical box cover.
3. Remove the connectors (CN17, CN22, CN11) from the low voltage PCB.
4. Detach two (2) hooks of the PCB base 1 fixing the low voltage PCB, lift the low voltage PCB and remove other connectors still connected.
5. Remove the earth wire from the heat exchanger, detach one (1) hook of the PCB base 2 fixing the high voltage PCB, lift the high voltage PCB and remove other connectors still connected.

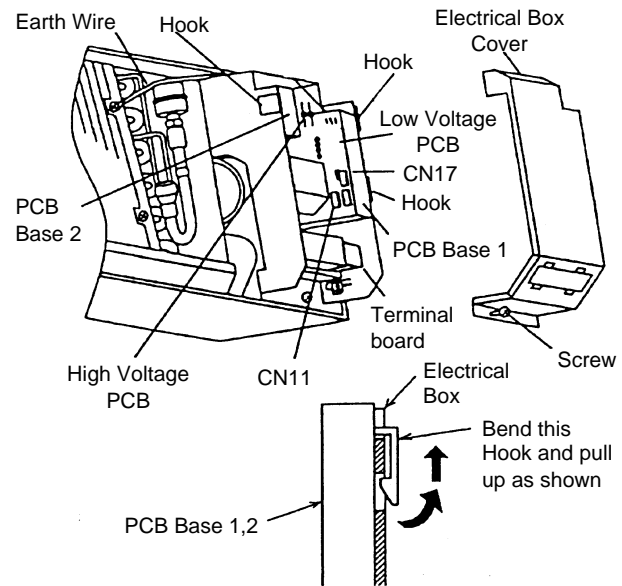

6. After the completion of replacement of PCB, connect the connectors to the PCB in the reverse procedures of removing. And firstly set the high voltage PCB to the electrical box and then set the low voltage PCB to the electrical box.

2.5.7 REMOVING DRAIN PAN

1. Remove the front panel according to the item 2.5.2, "Removing Front Panel".
2. Remove the electrical box according to the item 2.5.5, "Removing Electrical Box Cover".
3. Remove the drain pan from the unit by detaching the hooks (A) and (B) from the left side of the drain pan, and detaching the hook (C) by pulling the right side of the air panel toward the front side.
4. For attaching the drain pan, perform the reverse procedures for removing drain pan.

NOTE:

Check to ensure that the hooks (A), (B) and (C) are hooked correctly.

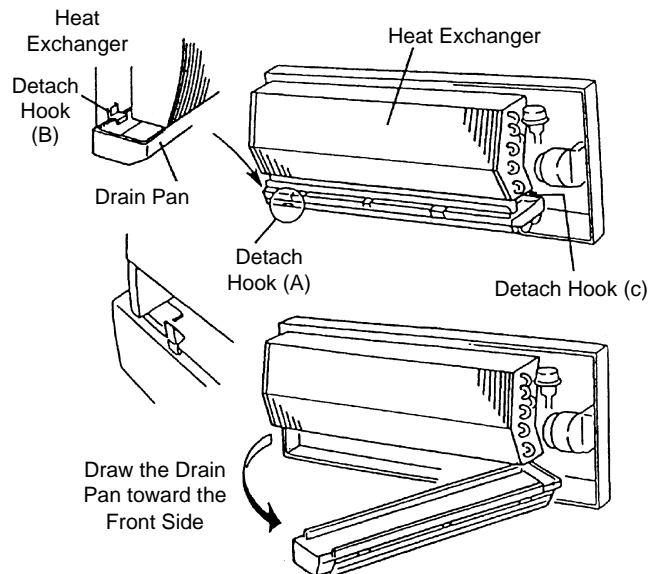

2.5.8 REMOVING HEAT EXCHANGER

1. Remove the front panel according to the item 2.5.2, "Removing Front Panel".
2. Remove the electrical box according to the item 2.5.5, "Removing Electrical Box Cover".
3. Remove the drain pan according to the item, 2.5.7, "Removing Drain Pan".
4. Remove the piping stay at the rear side of the indoor unit.

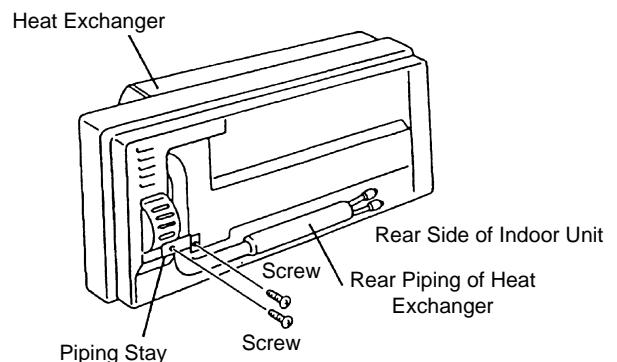

WARNING: TURN OFF all power source switches

- Detach the hook holding the left side of the heat exchanger and remove one (1) screw fixing the heat exchanger.

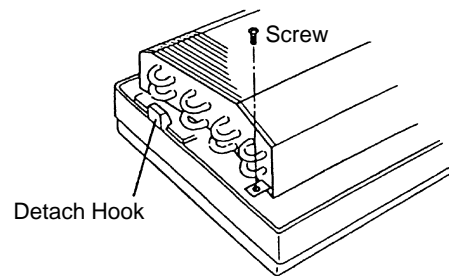

- Remove one (1) screw fixing the heat exchanger and detach the hook holding the right side of the heat exchanger.

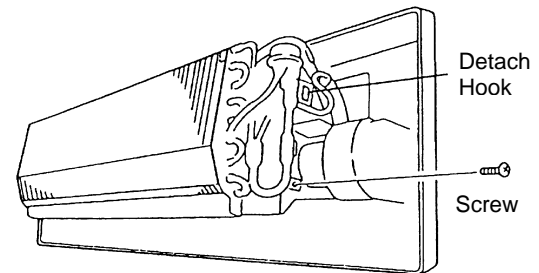

- Lift up the heat exchanger, Draw out the rear piping of the heat exchanger from the square hole by pulling the upper part of the heat exchanger forward and remove the heat exchanger.
- For attaching the heat exchanger, perform the reverse procedures for removing.

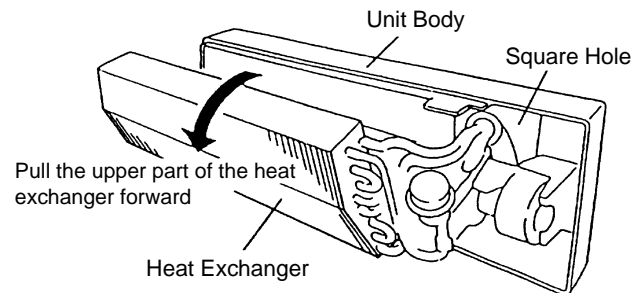

NOTE:

After attaching the heat exchanger, check to ensure that the hooks and the screws at the right and the left sides of the heat exchanger are correctly attached.

2.5.9 REMOVING FAN AND FAN MOTOR

- Remove the heat exchanger according to the item 2.5.8, "Removing Heat Exchanger".
- Remove the supporting plate for the bearing by pushing the knobs at both sides of the supporting plate toward the inside and detaching the hooks.

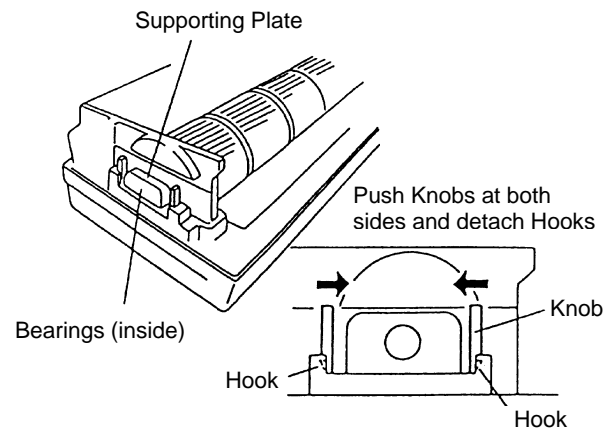

- Remove the motor holders 1 and 2 fixing the fan motor. For removing the motor holder, insert the screwdriver at the hook part and screw it.
- After removing the motor holder 1, loosen one screw (1) fixing the motor shaft and the fan.

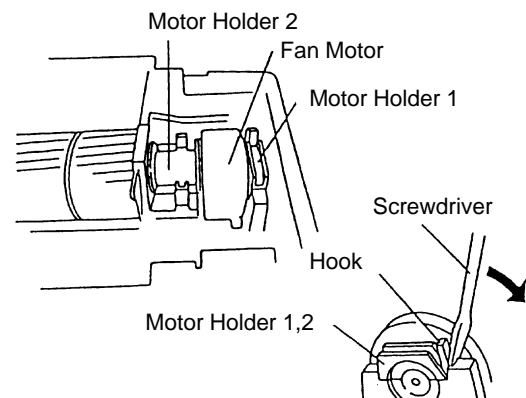

⚠ WARNING: TURN OFF all power source switches

5. Draw the fan leftward with lifting up the bearing side of the fan slightly, the fan and the fan motor are removed.
6. For attaching the fan motor and the fan, perform the reverse procedures for removing.
7. Fix the fan at the position with 8mm clearance between the left end (bearing side) of the fan and the partition plate.
8. Fix the fan motor with the outlet of the lead wire at the position as shown below.

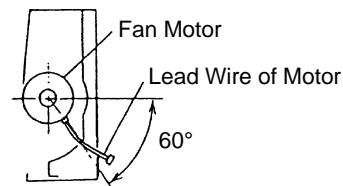
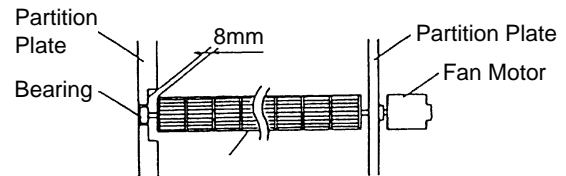
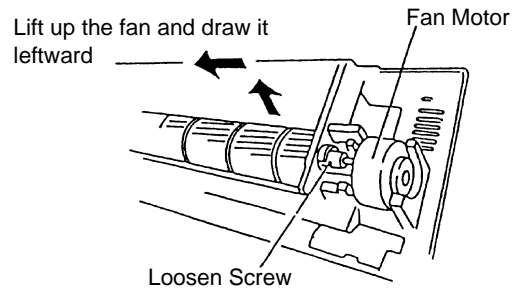

2.5.10 REMOVING ELECTRONIC EXPANSION VALVE COIL

1. Remove the front panel according to the item 2.5.2, "Removing Front Panel".
2. Remove the electrical box according to the item 2.5.5, "Removing Electrical Box Cover".
3. The butyl sheet is adhered around the piping of the heat exchanger, electronic expansion valve and the inlet and outlet piping of the electronic expansion valve. Remove the butyl sheet of the surface of the piping, the coil part of the expansion valve and the part of the valve body.
4. Prepare two (2) spanners. Hold the part of the valve body with one spanner and loosen the lock nut with another spanner by turning the lock nut counterclockwise.

NOTE:

Do not hold the motor part when loosening the lock nut by spanner. The base of the drive part may turn idle and be broken.

Turn the lock nut by a few turn, and the drive part is separated from the screw and can be removed. Prepare the new drive part for replacement (service part) with the position of the driver (drive screw) already adjusted.

NOTE:

During replacement work, pay attention to the separation part and prevent the dust, foreign particle, etc. from entering into the separation part. (The exposed part by separation is the mechanical part of the valve.)

Do not hurt the junction part of the valve with the tools.

Put the drive part onto the valve body, hold them with their axes matching and attach the lock nut to the screw part of the valve body. Tighten the lock nut with spanner after tightening lightly by hand.

The tightening torque shall be within the range of 12 Nm (120 kg-cm) ~ 15 Nm (150 kg-cm)

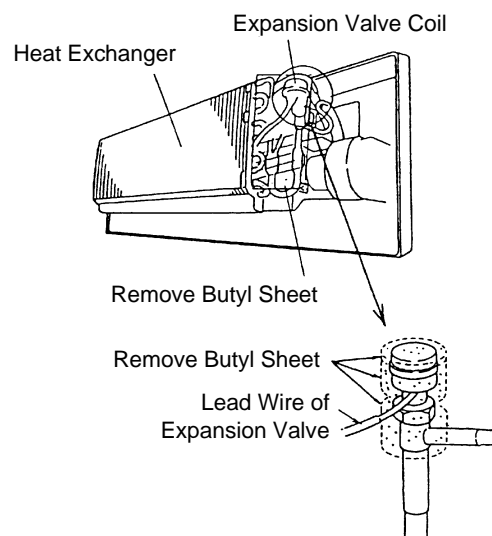

WARNING: TURN OFF all power source switches

NOTE:

Do not apply the strong forces such as the rotating torque and the bending load to the motor by holding the motor by hand when tightening the lock nut.

Although the direction of the eccentric part of the motor is assembled with the eccentric part of the motor directed toward the counterdirection of the fittings for piping at the valve body, the alteration of this direction do not affect the open/close function of the valve.

Therefore, the adjustment of the direction of the motor part is not required if the position of the motor is moved toward the rotating direction after replacement as shown in the Figure 2.

However, pay attention to the direction of the motor for the coil of the electronic expansion valve not to touch other pipings and the side plate of the electrical box.

5. Attach the removed butyl sheet to the electronic expansion valve again.
6. After completion of the replacement, attach the electronic expansion valve in the reverse procedures for removing.

Fig. 1. Expansion Valve

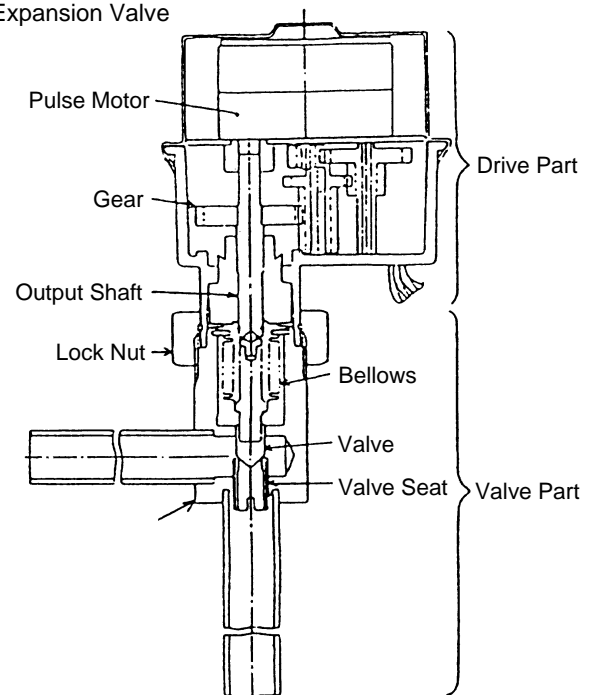
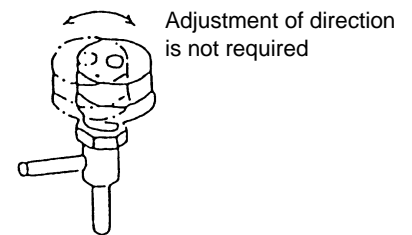

Fig. 2. Direction of Drive Part



2.6 FLOOR TYPE

2.6.1 REMOVING INTAKE AIR GRILLE

1. Loosen the screws for fixing plate at the right side of each intake air grille, and move the fixing plates.
2. By pushing the knob at both sides of the intake air grille towards the arrow mark direction, the grille can be opened with an angle of 30°
3. Remove it from the hinged part.

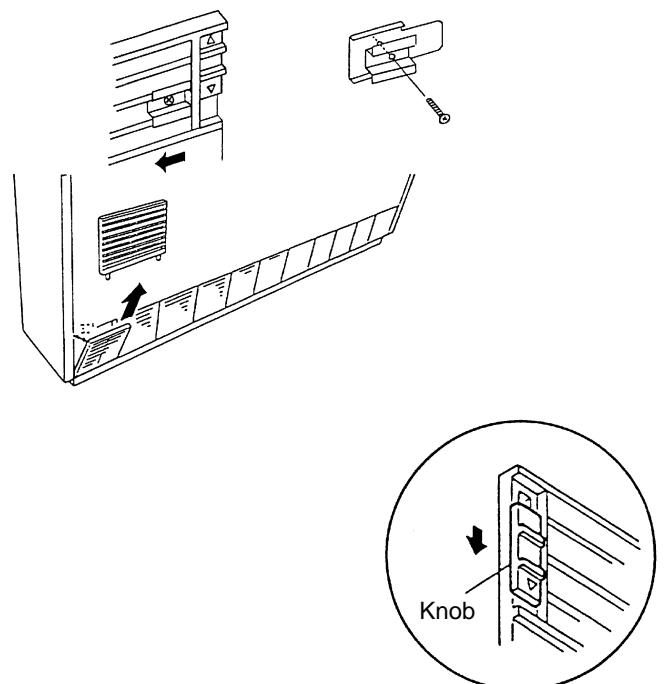

⚠ WARNING: TURN OFF all power source switches

2.6.2 REMOVING AIR FILTER

1. The air filter is located at the inner side of the intake air grille. Remove all the intake air grilles.
2. Remove the air filter by pulling the knob of the air filter.

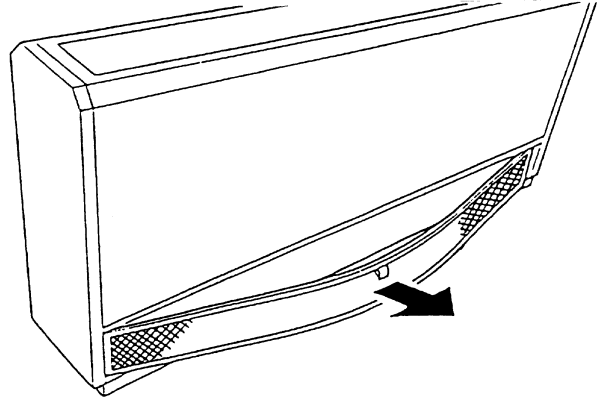

2.6.3 REMOVING DISCHARGE AIR GRILLE

1. The discharge air grilles are mounted on the top by using a guide-rail.
2. By opening the top cover and sliding the discharge air grilles, the grilles can be removed.

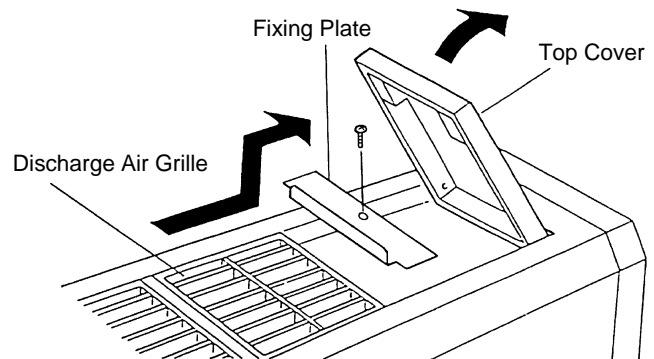

2.6.4 REMOVING FRONT COVER

1. Remove the air filter according to the item, 2.6.2, "Removing Air Filter".
2. Remove the front cover from the slit after removing four (4) fixing screws at the lower part and pulling it out downwards.

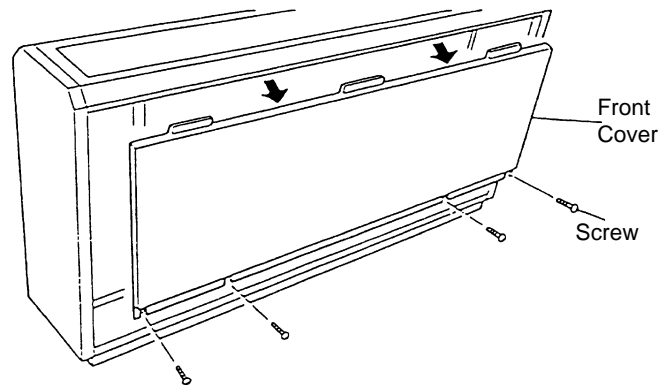

2.6.5 REMOVING FAN MOTOR

1. Remove the intake air grille according to the item, 2.6.1, "Removing Intake Air Grille".
2. Remove the air filter according to the item, 2.6.2, "Removing Air Filter".
3. Remove the front cover according to the item, 2.6.4, "Removing Front Cover".
4. Remove the mounting plate for the fan motor after removing four (4) fixing screws.

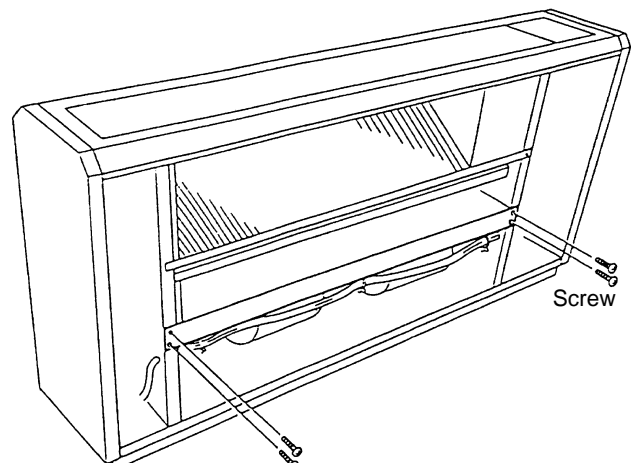

! **WARNING:** TURN OFF all power source switches

5. Disconnect the wiring connector for the fan motor. Remove the wiring assembly and connector.

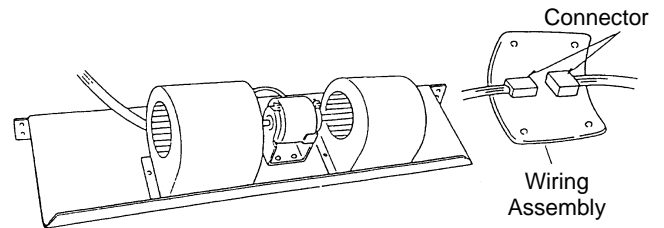

6. Remove the casing (1) by pushing the hook part at four (4) positions towards the inner side.

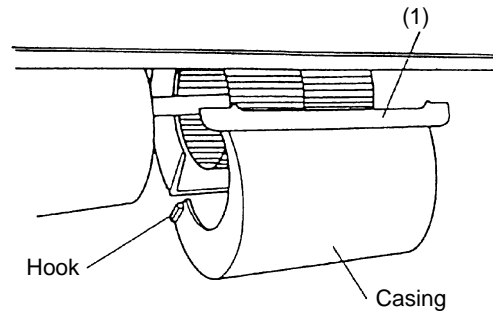

7. Loosen the screw by a hexagon wrench.

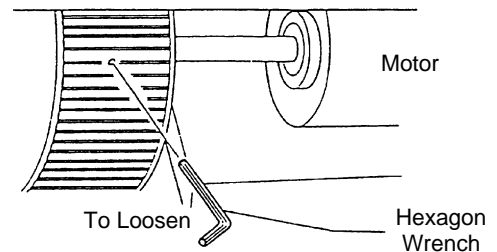

8. Remove the fan motor by sliding it backwards after removing the fixing plate. Pay attention not to drop it.

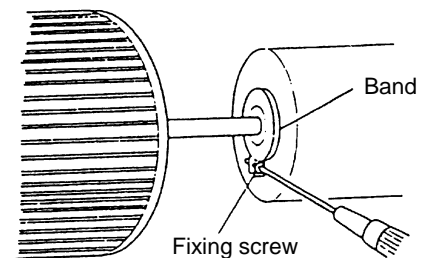

2.6.6 REMOVING PRINTED CIRCUIT BOARD (PCB)

1. Remove the intake air grille according to the item, 2.6.1, "Removing Intake Air Grille".
2. Remove the air filter according to the item, 2.6.2, "Removing Air Filter".
3. Remove the front cover according to the item, 2.6.4, "Removing Front Cover".
4. The side cover can be removed by removing three (3) fixing screws and pulling it downwards

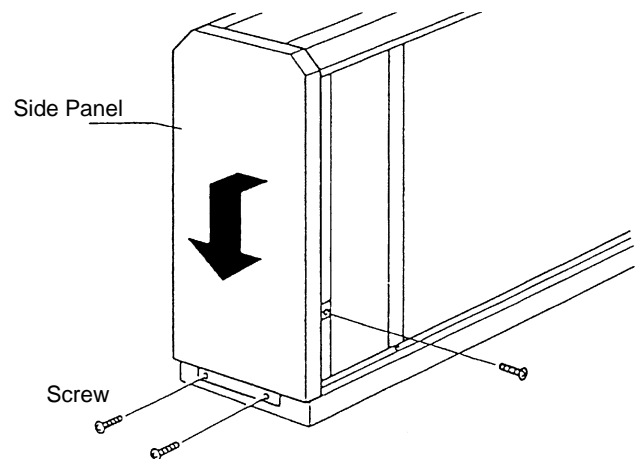

⚠ WARNING: TURN OFF all power source switches

5. Remove the electrical box cover after removing two (2) fixing screws.

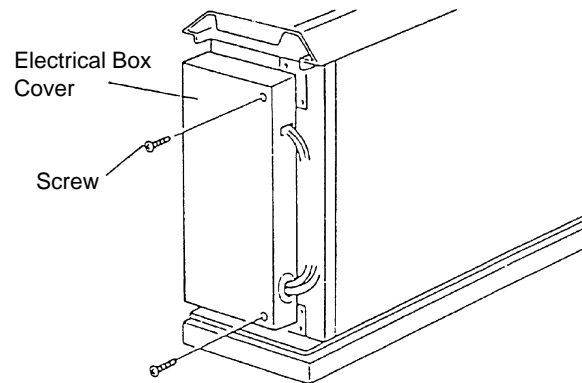

6. The electrical box can be turned up to an angle of 90° by removing two (2) fixing screws and unhooking the hook at the rear side of the electrical box.

7. The PCB is supported by four (4) holders. Pull out the PCB from the PCB hole by pushing the expanded part of the holder using long-nose pliers and putting a finger near the hole of the PCB.

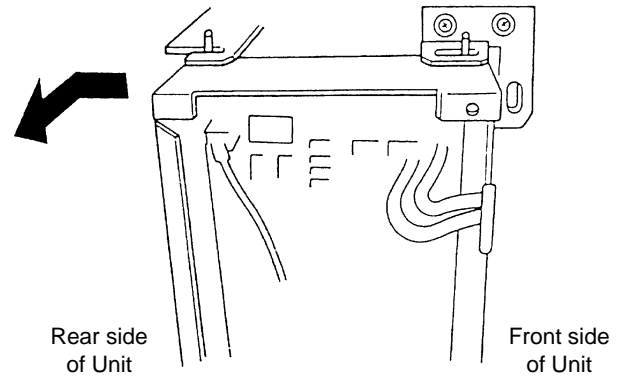

NOTES:

- 1 Do not touch electrical components. Do not apply big force to the PCB. If applied, the PCB will be faulty.
- 2 When reassembling, check to ensure that each terminal is correctly connected by referring to the wire marks and terminal codes. If incorrectly connected, malfunction or damage of electrical parts will occur.

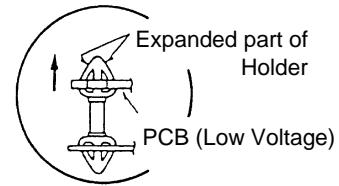

2.6.7 REMOVING THERMISTORS FOR LIQUID PIPE AND GAS PIPE

1. Remove the intake air grille according to the item, 2.6.1, "Removing Intake Air Grille".
2. Remove the air filter according to the item, 2.6.2, "Removing Air Filter".
3. Remove the front cover according to the item, 2.6.4, "Removing Front Cover".
4. Remove the side cover after removing three (3) fixing screws.

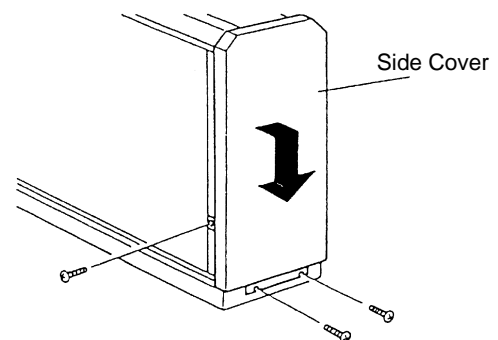

WARNING: TURN OFF all power source switches

- Remove the piping cover after removing two (2) fixing screws for the partition plate and four (4) fixing screws for piping cover

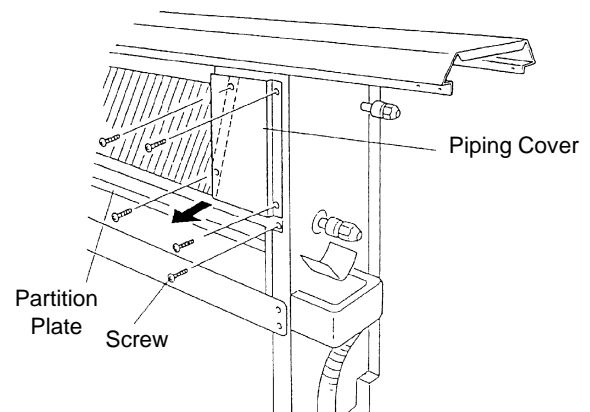

- Remove CORK TAPE and pull out the thermistor after removing the thermo clip for the thermistors. Seal the thermistor with CORK TAPE. Mount it as shown beside.

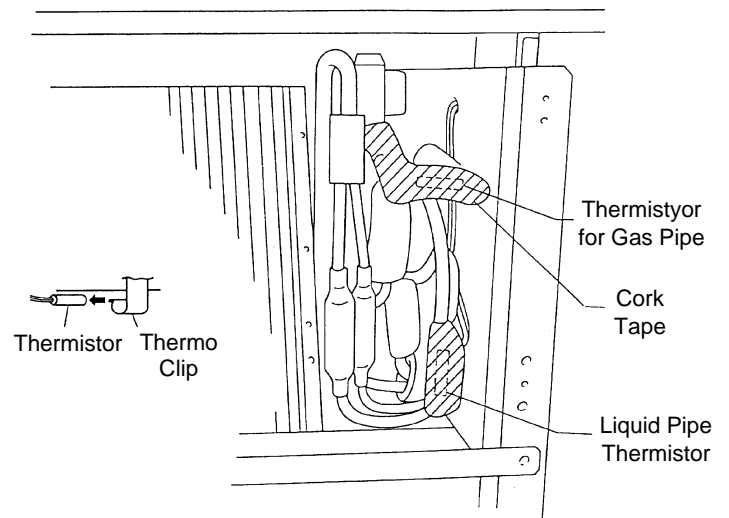

2.7 FLOOR CONCEALED TYPE

2.7.1 REMOVING AIR FILTER

- The air filter is located at the inner upper part of the inlet.
- Remove the air filter by pulling the center knob and bending the filter.

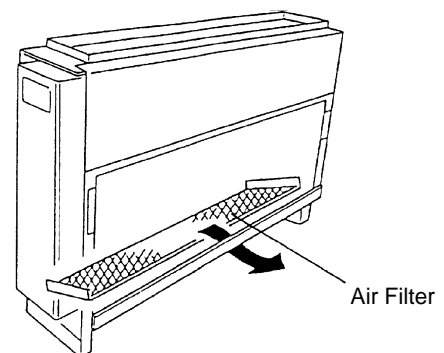



WARNING: TURN OFF all power source switches

2.7.2 REMOVING FRONT COVERS

1. Remove the air filter according to the item, 2.7.1, "Removing Air Filter".
2. Remove the front lower cover after removing screws (1.0HP: 9pcs., 1.5HP: 10pcs.) at the lower part of the front cover.
3. Remove the front upper cover after removing eleven (11) fixing screws.

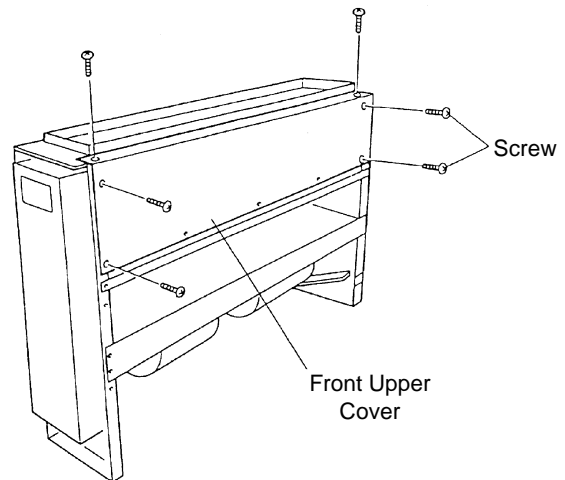
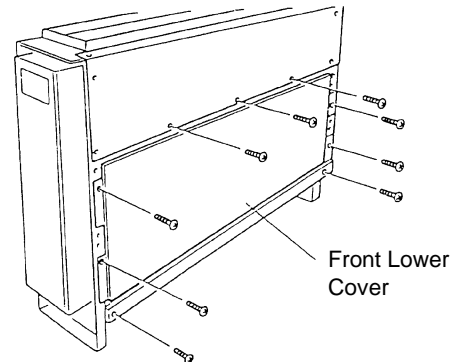

2.7.3 REMOVING FAN MOTOR

1. Remove the air filter according to the item, 2.7.1, "Removing Air Filter".
2. Remove the front covers according to the item, 2.7.2, "Removing Front Covers".
3. Remove the fan motor as same as indicated in No. 4 to No.8 of the item, 2.6.5, "Removing Fan Motor".

2.7.4 REMOVING PRINTED CIRCUIT BOARD (PCB)

1. Remove the front covers according to the item, 2.7.2, "Removing Front Covers".
2. Remove the PCBs as same as indicated in No. 5 to No.7 of the item, 2.6.6, "Removing Printed Circuit Board (PCB)".

2.7.5 REMOVING THERMISTORS FOR LIQUID PIPE AND GAS PIPE

1. Remove the air filter according to the item, 2.7.1, "Removing Air Filter".
2. Remove the front covers according to the item, 2.7.2, "Removing Front Covers".
3. Remove the thermistor as same as indicated in No. 4 to No.6 of the item, 2.6.7, "Removing Thermistors for Liquid Pipe and Gas Pipe".

! **WARNING:** TURN OFF all power source switches

2.8 CEILING TYPE

2.8.1 REMOVING AIR FILTER

1. The air filter is located inside of the intake air grille.
Remove the air filter after opening the intake air grilles.
2. Push the knobs of the intake air grille backwards.
3. Open the intake air grille downwards.
4. By lifting the knob upwards, the filter can be removed.

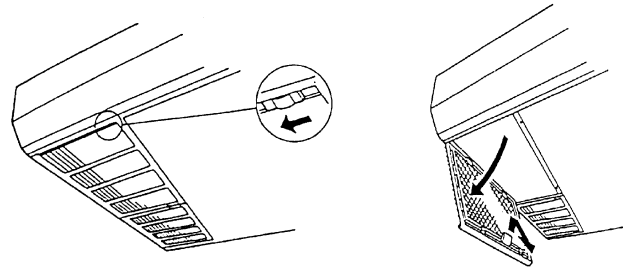

2.8.2 REMOVING SIDE COVER

1. Pull the side cover towards you.
2. Unhook the hook at the lower part of the side cover.
3. Lift it upwards.

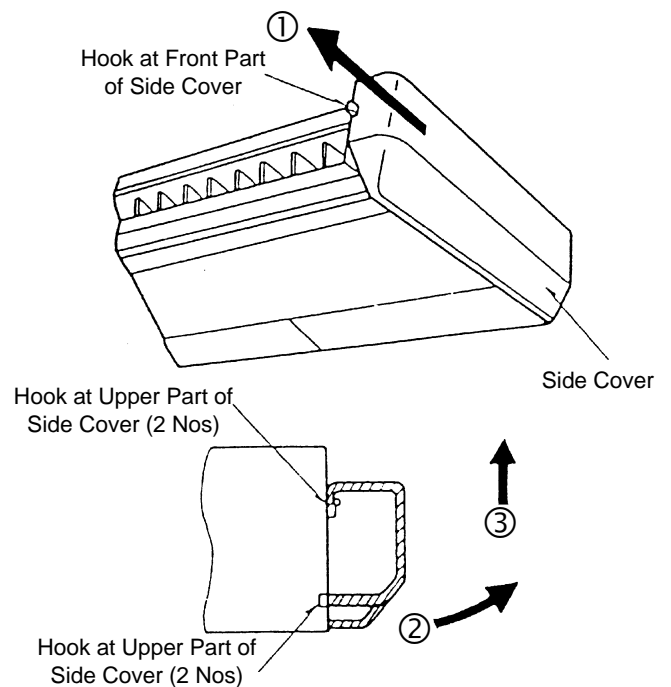

2.8.3 REMOVING DISCHARGE AIR GRILLE

1. Remove the side covers according to the item, 2.8.2, "Removing Side Cover".
2. Remove the crank assembly mounted on the right side shaft of the air deflector.

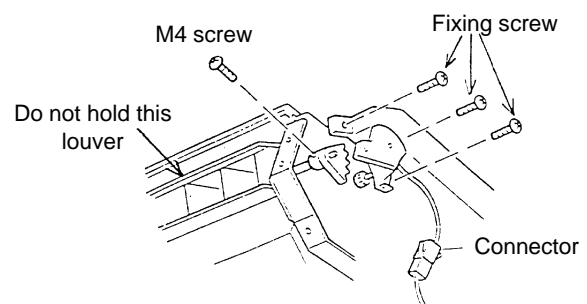

⚠ WARNING: TURN OFF all power source switches

3. Pull out the deflector including the bearing after removing four (4) fixing screws at the right and left.

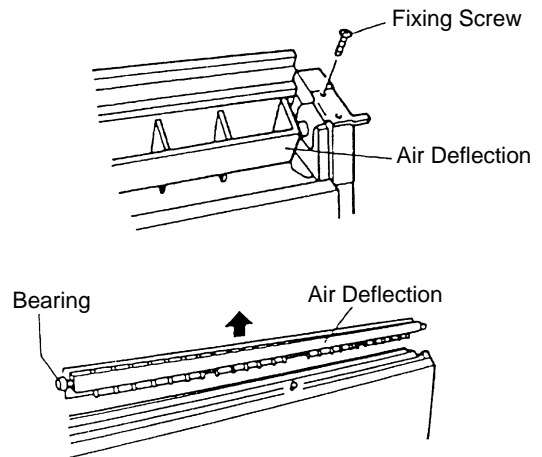

2.8.4 REMOVING FAN MOTOR

1. Open the intake air grille according to the item, 2.8.1, "Removing Air Filter".
2. Remove the stay at the air inlet.

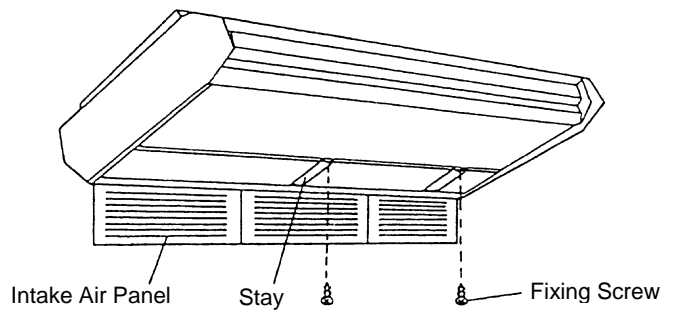

3. Disconnect the connector for the indoor fan motor.

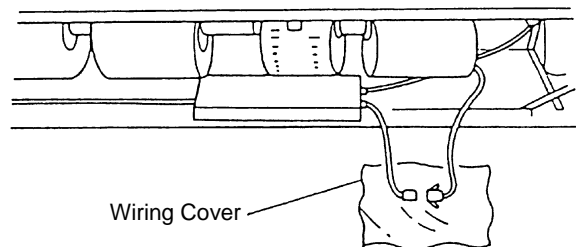

4. Hook the electrical box on the lower frame after removing the screws fixing the electrical box.

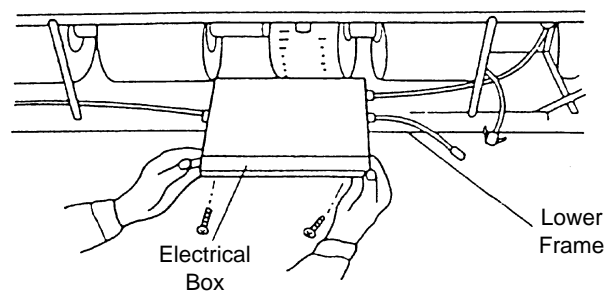

NOTE:

During this work, support the electrical box by hands not to drop it.

WARNING: TURN OFF all power source switches

- Remove the casing (1) by pushing the hook part at four (4) positions towards the inner side.

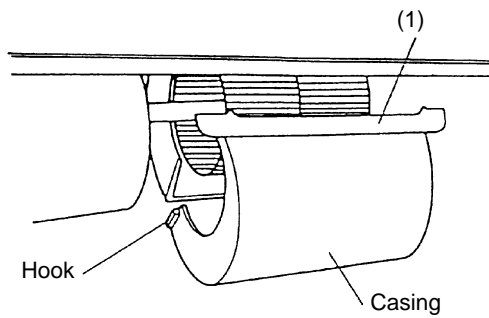

- Loosen the screws by a hexagon wrench.

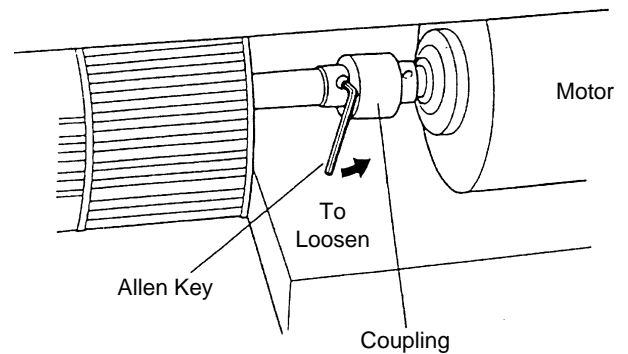

- Remove the fan motor by sliding it backwards after removing the fixing band. Pay attention not to drop it.

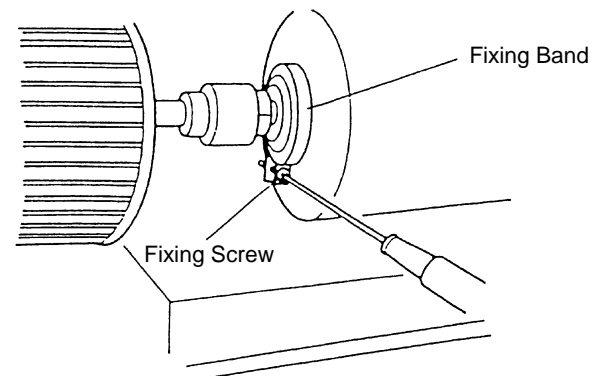

2.8.5 REMOVING BEARING

- Remove the side covers according to the item, 2.8.2, "Removing Side Cover".
- Loosen two (2) screws fixing the bearing and shaft by a hexagon wrench.
- Remove the bearing after removing two (2) fixing screws (M8).

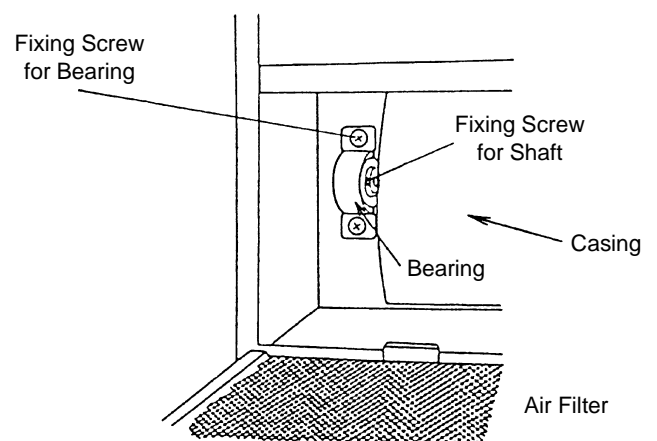

⚠ WARNING: TURN OFF all power source switches

2.8.6 REMOVING COUPLING

1. Remove the side covers according to the item, 2.8.2, "Removing Side Cover".
2. Separate the casing into two (2) pieces according to the item, 2.8.4, "Removing Fan Motor".
Loosen the screw for the coupling by a hexagon wrench.
3. Remove the M8 screw fixing the bearing according to the item, 2.8.5, "Removing Bearing".
4. Remove the coupling after removing the shaft and turbo fan assembly.

2.8.7 REMOVING AUTOMATIC LOUVER MOTOR

1. Remove the right side cover according to the item 2.8.2 "Removing Side Cover".
2. Remove the M4 screws and remove the AS motor assembly from the right shaft of the discharge air grille. Pay attention not to damage the AS motor assembly.
3. Remove two (2) screws (A) fixing the motor for auto louver and remove the motor from the AS motor fixing plate. Remove one (1) screw (B) fixing the shaft of the motor for auto louver and pinion AS.

NOTE:

When assembling, tighten two (2) screws (A) with a torque of 0.8Nm (8kg-cm) and one screw (B) with a torque of 0.4 Nm (4kg-cm) using a torque wrench.

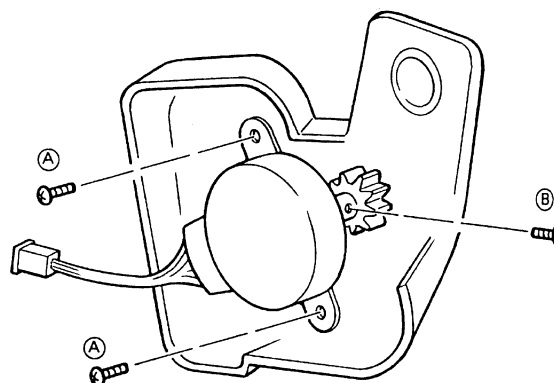

2.8.8 REMOVING THERMISTORS FOR LIQUID PIPE AND GAS PIPE

1. Remove the right and left side covers according to the item, 2.8.2, "Removing Side Cover".
2. Remove the lower cover.

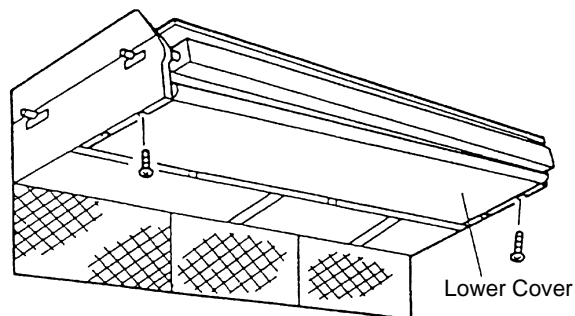

3. Remove the drain pan after disconnecting the drain hose.

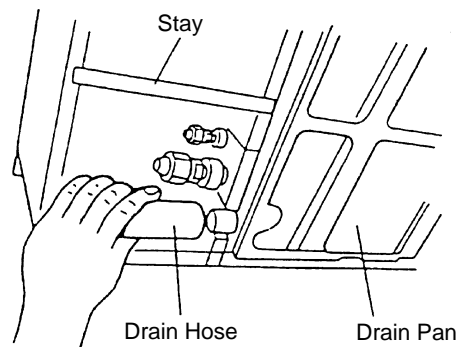

WARNING: TURN OFF all power source switches

- Remove the thermistors for the liquid pipe and gas pipe.

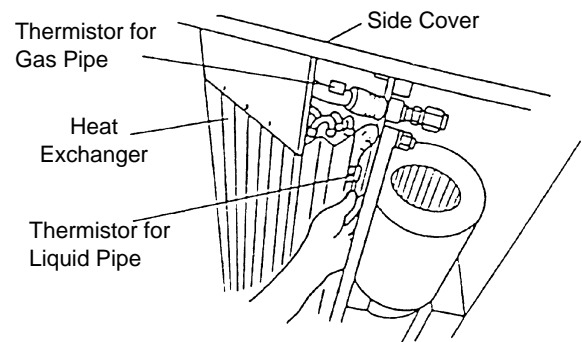

2.8.9 REMOVING PRINTED CIRCUIT BOARD (PCB)

- Open the intake air panel according to the item, 2.8.1, "Removing Air Filter".
- Disconnect the wiring connector for the fan motor.
- Turn the electrical box according to No. 4 of the item, 2.8.4, "Removing Fan Motor" and hook the electrical box at the lower frame.
- Remove the cover after removing two (2) screws fixing electrical box cover.

NOTE:

During this work, support the electrical box not to drop it.

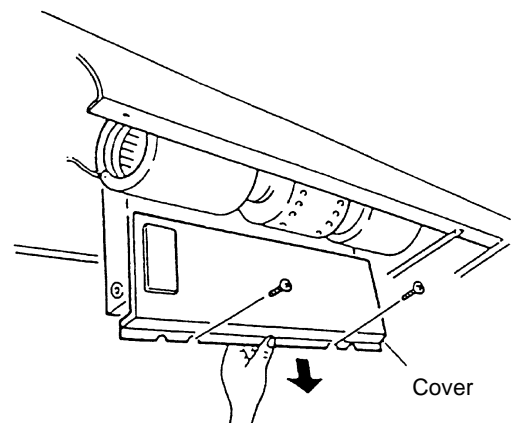

- The PCB is supported by four (4) holders. Pinch the expanded part of the holder with long-nose pliers

NOTE:

Do not touch the electrical components. Do not apply big force to the PCB. If applied, the PCB will be faulty.

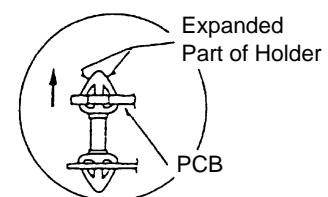
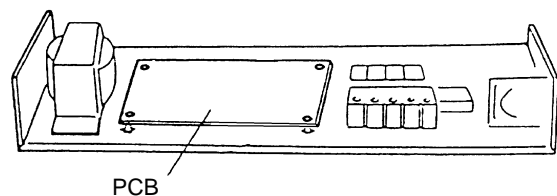

2.9 TOTAL HEAT EXCHANGER

2.9.1 REMOVING AIR FILTER

- Turn off the power source for the total heat exchanger.
- Remove the check panel at the side of the unit, and the air filters for supply air and exhaust air can be removed. (The check panel is fixed with four (4) M6 screws.)

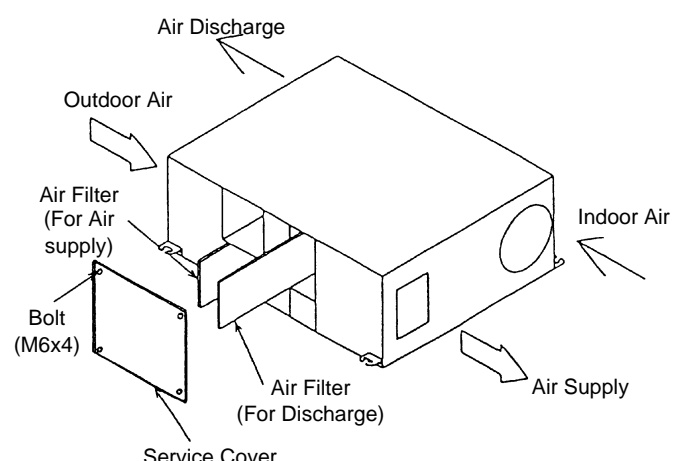

! **WARNING:** TURN OFF all power source switches

2.9.2 REMOVING TOTAL HEAT EXCHANGING ROTOR

1. Turn off the power source for the total heat exchanger.
2. Remove the air filters for supply air and exhaust air before removing the total heat exchanging rotor.
3. Remove the check panel, and the total heat exchanging rotor can be removed by drawing out from the side of the unit as shown below. When removing the total heat exchanging rotor, remove the connector of the motor wire for the rotor (with black cover).

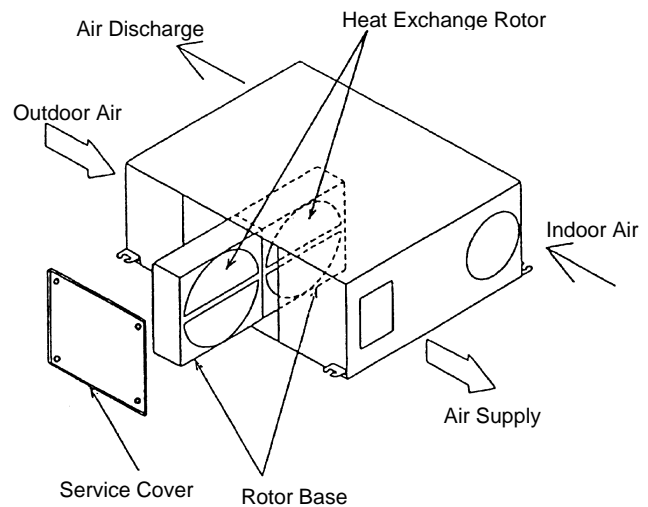

2.9.3 REMOVING AIR SUPPLY FAN ASSEMBLY AND EXHAUST FAN ASSEMBLY

1. Turn off the power source for the total heat exchanger.
2. Remove the air filters and the total heat exchanging rotor according to the items, 2.9.1 and 2.9.2 before removing the air supply fan assembly and the exhaust fan assembly.
3. Remove the air supply side partition plate and the exhaust side partition plate.
The supply air side partition plate is fixed with one (1) screw and the exhaust air side partition plate with three (3) screws at the check hole side. Remove these screws and remove these plates by drawing towards the center of the unit.

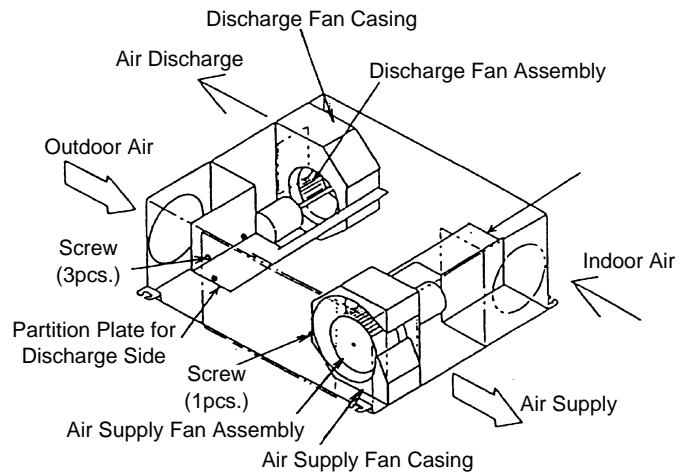

4. When removing the fan assembly, remove the eight (8) M6 bolts fixing the motor base to the unit and suction bell-mouth fixed to the fan casing together. The suction bell-mouth can be removed when the cut-out part of the bell-mouth is horizontal by rotating counterclockwise. Remove the air supply fan assembly by pulling out from the fan casing, drawing towards the center and drawing out towards the front side. Remove the exhaust fan assembly by pulling out from the fan casing, drawing towards the center and drawing out towards the front side.

2.10 CLEANING INDOOR UNIT HEAT EXCHANGER

2.10.1 REQUIRED TOOLS FOR CLEANING (FOR ALL INDOOR UNITS)

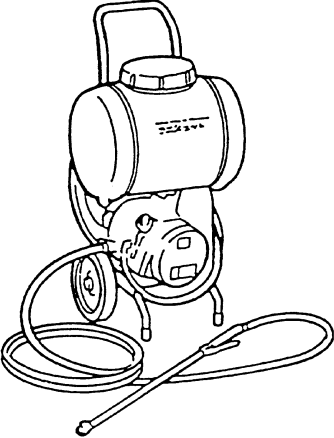
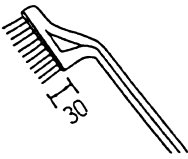
No.	Tool	Remark
1	Cleaning Water Pump 	A water pump equipped with a tank is recommended
2	Water Tank Clean Water	Approx. 18 liters
3	Nozzle	
4	Brush (non-metal) 	If the heat exchanger is heavily clogged with dust, remove it with this brush. The length of brush should be 25 ~ 35mm.
5	Hose for Water Pan	Select a hose according to site requirements
6	Bucket	2 Nos. for 5 liters
7	Phillips Screwdriver	1 No.
8	Nipper	1 No
9	Adjustable Wrench	1 No.
10	Megohm Tester	500V
11	Cleaning Agent	Select a neutral type cleaning agent
12	Spray	To spray cleaning water
13	Tape with Adhesive	To fix the vinyl sheet to protect the room from cleaning water
14	Rope	1m, 4 Pieces
15	Vinyl Sheet	Select a vinyl sheet with 0.5mm thickness.
16	Gloves	

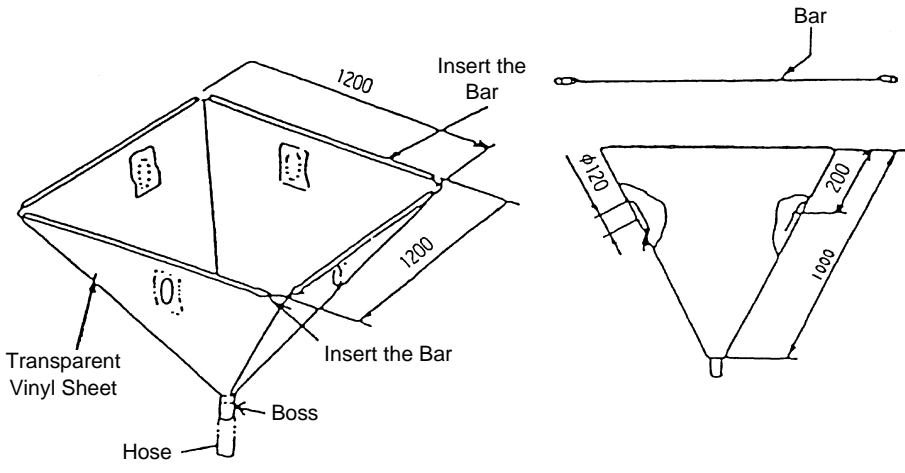
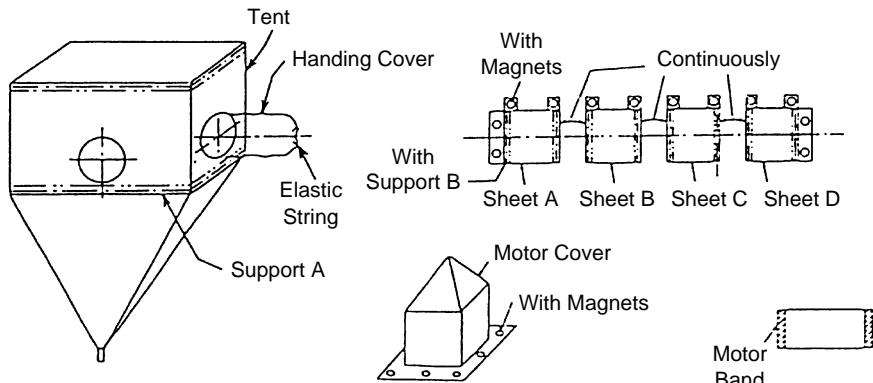
No.	Remark																																																															
17	<p>Cleaning Water Collector</p> <ul style="list-style-type: none"> ■ In-the-Celing Type ■ 2-Way Cassette Type ■ Wall Type ■ Ceiling Type  <p>Inner Side of Ø120 hole should be covered with felt sheet to insert the spray nozzle.</p>																																																															
18	<p>Cleaning Water Collector Kit</p> <ul style="list-style-type: none"> ■ 4-Way Cassette Type <table border="1" data-bbox="239 1008 1372 1456"> <thead> <tr> <th>No</th> <th>Part</th> <th>Material</th> <th>Remarks</th> <th>Q'ty</th> </tr> </thead> <tbody> <tr> <td>1</td> <td>Tent with Handling Cover</td> <td>Vinyl Chloride Sheet</td> <td>1t, with Handling Cover 0.3t</td> <td>1</td> </tr> <tr> <td>2</td> <td>Support A</td> <td>Stainless</td> <td></td> <td>8</td> </tr> <tr> <td>3</td> <td>Sheet A</td> <td>Vinyl Chloride Sheet</td> <td>1t, with Support B and Magnet</td> <td>1</td> </tr> <tr> <td>4</td> <td>Sheet B</td> <td>Vinyl Chloride Sheet</td> <td>1t, with Support B and Magnet</td> <td>1</td> </tr> <tr> <td>5</td> <td>Sheet C</td> <td>Vinyl Chloride Sheet</td> <td>1t, with Support B and Magnet</td> <td>1</td> </tr> <tr> <td>6</td> <td>Sheet D</td> <td>Vinyl Chloride Sheet</td> <td>1t, with Support B and Magnet</td> <td>1</td> </tr> <tr> <td>7</td> <td>Motor Cover</td> <td>Vinyl Chloride Sheet</td> <td>1t, with Magnet</td> <td>1</td> </tr> <tr> <td>8</td> <td>Motor Band</td> <td>Vinyl Chloride Sheet</td> <td>1t, Magic Tape</td> <td>1</td> </tr> <tr> <td>9</td> <td>Wiring Cover</td> <td>Vinyl Chloride Sheet</td> <td></td> <td>1</td> </tr> <tr> <td>10</td> <td>Gloves</td> <td>Rubber</td> <td></td> <td>1</td> </tr> <tr> <td>11</td> <td>Sling Rope</td> <td></td> <td>1 m</td> <td>4</td> </tr> </tbody> </table> 				No	Part	Material	Remarks	Q'ty	1	Tent with Handling Cover	Vinyl Chloride Sheet	1t, with Handling Cover 0.3t	1	2	Support A	Stainless		8	3	Sheet A	Vinyl Chloride Sheet	1t, with Support B and Magnet	1	4	Sheet B	Vinyl Chloride Sheet	1t, with Support B and Magnet	1	5	Sheet C	Vinyl Chloride Sheet	1t, with Support B and Magnet	1	6	Sheet D	Vinyl Chloride Sheet	1t, with Support B and Magnet	1	7	Motor Cover	Vinyl Chloride Sheet	1t, with Magnet	1	8	Motor Band	Vinyl Chloride Sheet	1t, Magic Tape	1	9	Wiring Cover	Vinyl Chloride Sheet		1	10	Gloves	Rubber		1	11	Sling Rope		1 m	4
No	Part	Material	Remarks	Q'ty																																																												
1	Tent with Handling Cover	Vinyl Chloride Sheet	1t, with Handling Cover 0.3t	1																																																												
2	Support A	Stainless		8																																																												
3	Sheet A	Vinyl Chloride Sheet	1t, with Support B and Magnet	1																																																												
4	Sheet B	Vinyl Chloride Sheet	1t, with Support B and Magnet	1																																																												
5	Sheet C	Vinyl Chloride Sheet	1t, with Support B and Magnet	1																																																												
6	Sheet D	Vinyl Chloride Sheet	1t, with Support B and Magnet	1																																																												
7	Motor Cover	Vinyl Chloride Sheet	1t, with Magnet	1																																																												
8	Motor Band	Vinyl Chloride Sheet	1t, Magic Tape	1																																																												
9	Wiring Cover	Vinyl Chloride Sheet		1																																																												
10	Gloves	Rubber		1																																																												
11	Sling Rope		1 m	4																																																												

! WARNING: TURN OFF all power source switches

2.10.2 CLEANING 4-WAY CASSETTE TYPE INDOOR UNIT

- Spread a vinyl sheet over the floor to protect furnitures, etc. from cleaning water before this work.

Procedure:

- 1 Remove the optional air panel according to page 2-15 and the item, 2.3.4, "Removing Optional Air Panel".
 - 2 Remove the electrical box after opening the electrical box cover and disconnecting the connectors between the indoor and outdoor units and other connectors according to page 2-15 and the item, 2.3.3, "Removing Electrical Box Cover".
 - 3 Remove the bell-mouth and fan according to page 2-16 and the item, 2.3.5, "Removing Turbo Fan and Fan Motor".
 - 4 Remove the drain pan according to page 2-19 and the item, 2.3.9, "Removing Drain Pan".
 - 5 Remove the float switch according to page 2-18 and the item, 2.3.7, "Removing Float Switch".
 - 6 Remove the drain-up mechanism according to page 2-18 and the item, 2.3.8, "Removing Drain-up Mechanism".
1. Attach a vinyl sheet around the heat exchanger so that cleaning water will not be splashed over the insulation surface and drain-up pump. Fix the vinyl sheet on the side plate of the heat exchanger by using tape with adhesive. Seal the gap between vinyl sheets using tape with adhesive.

NOTE:

Wear gloves to avoid any injury by fins of the heat exchanger.
In addition to magnets, fix the motor cover using tape with adhesive

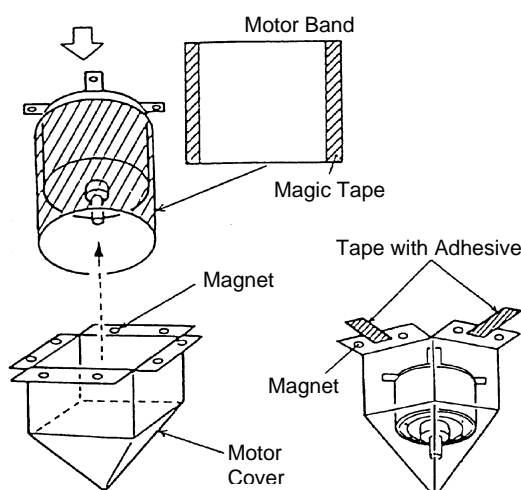

NOTES:

Remove the drain pan after removing drain water on the drain pan.

- 1 Remove the drain water on the drain pan after pulling out the rubber plug. Check to ensure that water can flow smoothly through the hole by pricking it with a pencil.
- 2 Remove the drain pan after removing four fixing screws. Carefully remove the drain pan, since drain water may remain at the bottom of the drain pan.
- 3 Clean and dry the drain pan after removing. Carefully handle the drain pan not to damage it.

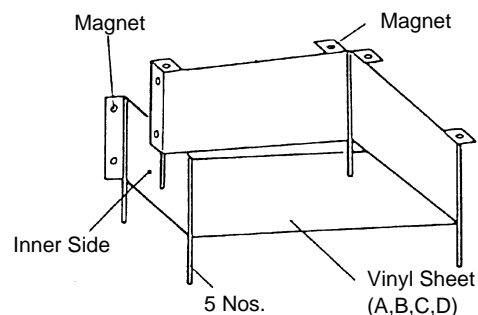
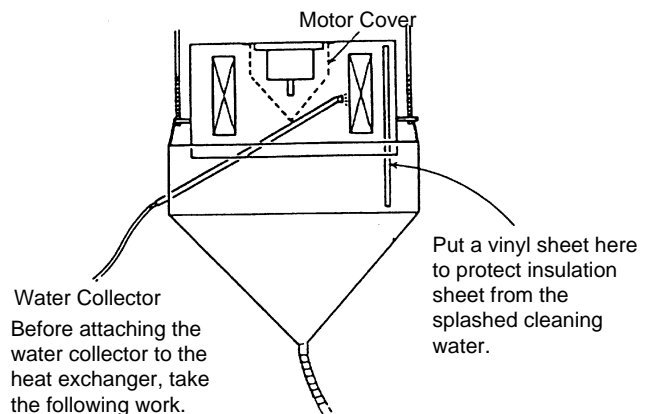

⚠ WARNING: TURN OFF all power source switches

2. Scratch off the dust on the inner surface of the heat exchanger downwards using a brush. Collect all dust in a bucket or carton box.

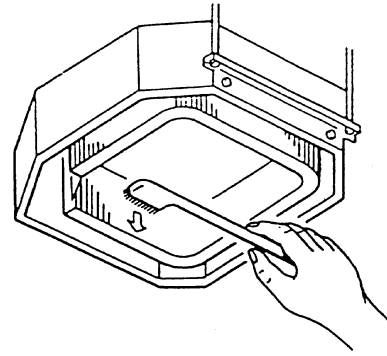

3. Suspend the cleaning water collector from the indoor unit.
 - a. Tie the rope on the suspension bolts for the indoor unit and put it downwards.
 - b. Insert the support bars into the holes of the water collector.
 - c. Tie the rope on the support bar of the water collector and suspend the water collector.
 - d. Connect a hose to the boss and put the end of the hose in a bucket.

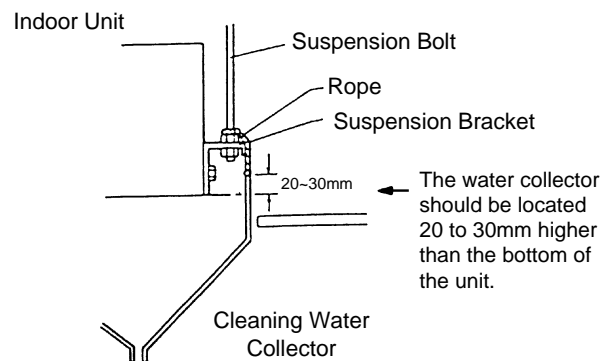
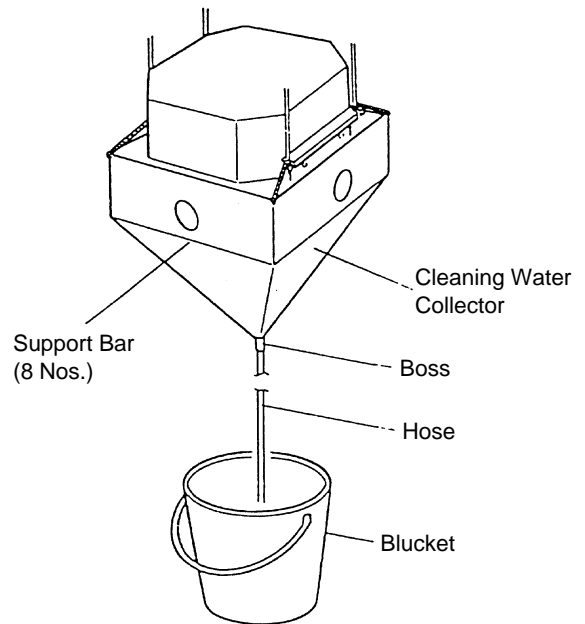

4. Put approximately 15 liters of cleaning agent for aluminum fins in a supply tank.

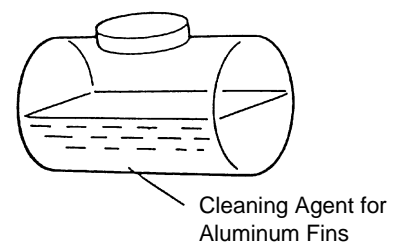

! **WARNING:** TURN OFF all power source switches

5. Insert the spray nozzle through the hole of the cleaning water collector. Operate the water pump and clean the dust on the heat exchanger. After cleaning, spray clean water to remove the cleaning water. Adjust the pressure of the water pump so as not to damage the fins.

NOTE:

*If the cleaning water remains, fins will be corroded.
Adjust the pressure of the pump at 2.5 to 5.0 kg/cm² so as not to damage fins.*

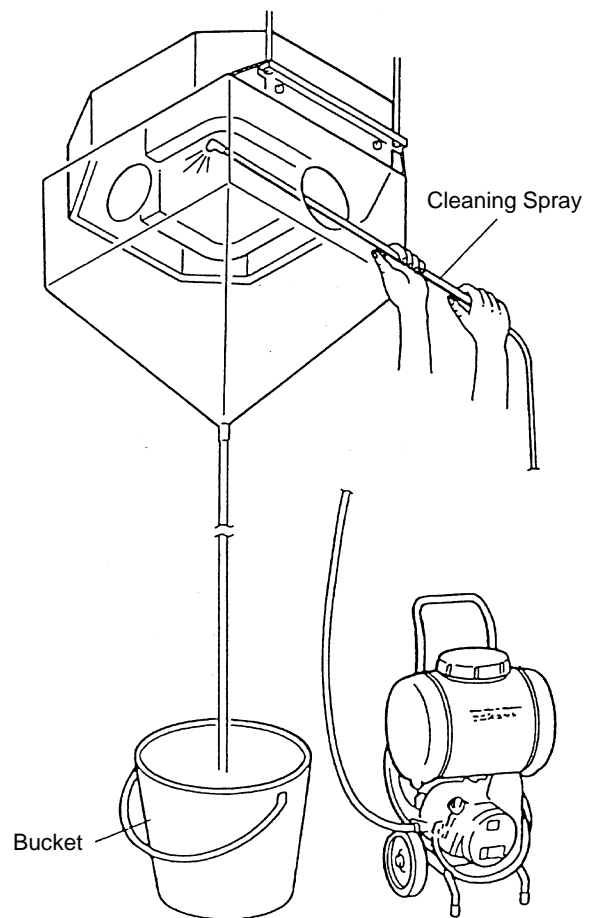

6. After cleaning, mount the drain pan by extending the rope downwards.

NOTE:

In the case that the cleaning water collector is removed, wipe off the drops from the indoor unit.

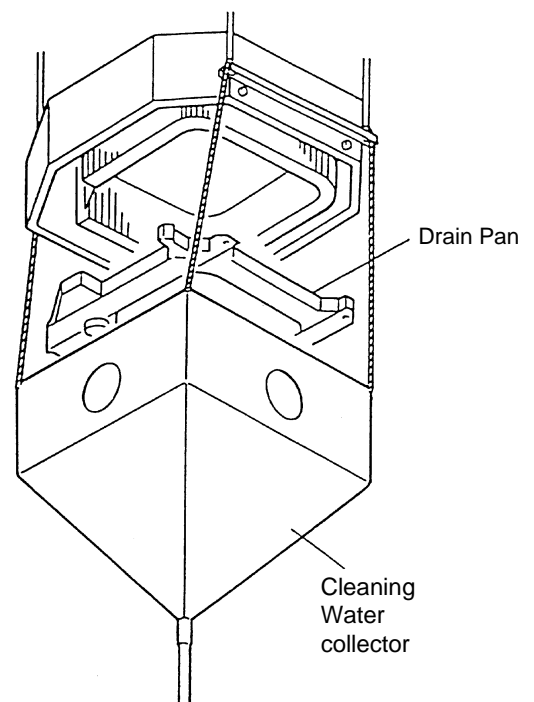

⚠ WARNING: TURN OFF all power source switches

7. Check the insulation of the drain pump with a megohm-meter. Check to ensure that the insulation is greater than 1 MΩ when 500V is applied.
8. Connect wiring as it was.
9. Neutralization Treatment after Cleaning
The cleaning agent specified in the item, 2.10.1 is of the neutral type. However, the cleaning water after use may be not neutral. Collect all cleaning water and make necessary neutralization treatment for the cleaning water.

2.10.3 CLEANING 2-WAY CASSETTE TYPE INDOOR UNIT

- Spread a vinyl sheet over the floor to protect furnitures, etc. from cleaning water before this work

1. Remove the drain pan according to page 2-26 and the item, 2.4.11, "Removing Drain Pan". Clean the drain pan after removal.
2. Remove the Float Switch according to page 2-26 and the item, 2.4.9, "Removing Float switch"
3. Remove Drain-Up Mechanism according to page 2-26 and the item, 2.4.10, "Removing Drain-Up Mechanism"

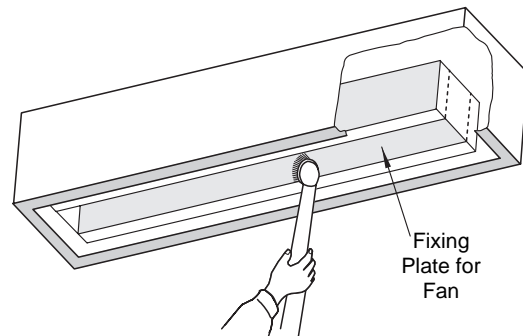

4. Removing Dust on Heat Exchanger
Remove dust on the fins at the inlet side of the heat exchanger by scratching off downwards.
Collect all dust in a bucket or carton box.

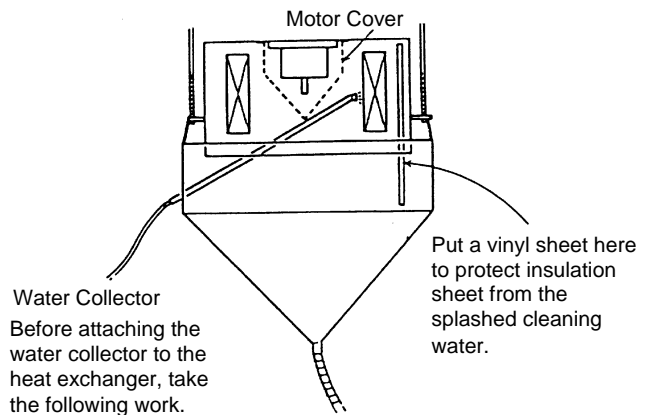

5. Put a vinyl sheet around the heat exchanger so that cleaning water will not be splashed over the insulation surface and drain-up pump. Fix the vinyl sheet on the side plate of the heat exchanger by using tape with adhesive. Seal the gap between vinyl sheets using tape with adhesive.

NOTE:

*It is recommended that gloves be used during this work to avoid any injury.
Put a vinyl sheet to avoid splashed cleaning water.*

! **WARNING:** TURN OFF all power source switches

6. Suspend the cleaning water collector from the indoor unit.
 - a. Connect a rope to the suspension bracket of the indoor unit put is downwards.
 - b. Insert the support bar into the cleaning water collector hole.
 - c. Suspend the cleaning water collector with the rope from the indoor unit.
 - d. Connect a hose to the boss for the cleaning water collector and put the other end in a bucket.
7. Spraying Cleaning Water
Spray the cleaning water over the fins of the heat exchanger.

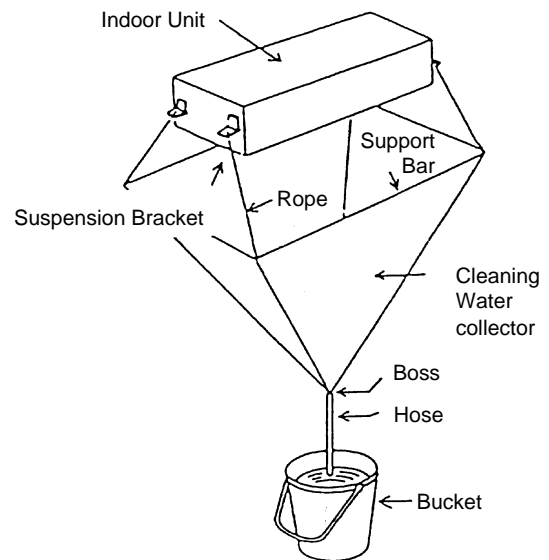

8. Cleaning with Clean Water
Insert the spray nozzle through the hole of the cleaning water collector.
Operate the pump and clean the fins with clean water.
Adjust the water pump pressure so as not to damage the fins.

NOTE:

*If the cleaning water remains, fins will be corroded.
Adjust the pressure of the pump at 2.5 to 5.0 kg/cm² so as not to damage fins.*

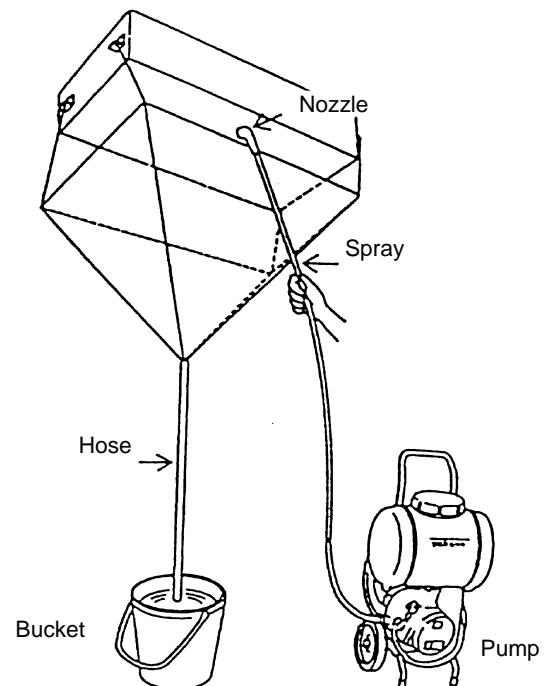

9. Attach the fan assembly and drain pan after cleaning is completed and dropping of cleaning water is stopped.
10. Check the insulation of drain-up pump by megohm-meter. Check to ensure that the insulation is greater than 1 MΩ when 500V is applied.
11. Connect the wiring as it was. Mount the air distribution chamber and optional air panel
12. Neutralization Treatment after Cleaning
The cleaning agent specified in the item, 2.10.1 is of the neutral type. However, the cleaning water after use may be not neutral. Collect all cleaning water and make necessary neutralization treatment for the cleaning water.

! **WARNING:** TURN OFF all power source switches

2.10.4 CLEANING WALL TYPE INDOOR UNIT

■ Spread a vinyl sheet over the floor to protect furnitures, etc. from cleaning water before this work

1. Remove each parts according to the item 2.5. "Wall Type".
2. Remove the front panel according to page 2-29 and the item 2.5.2, "Removing Front Panel".
3. Remove the electrical box according to page 2-31 and the item 2.5.5, "Removing Electrical Box Cover".
4. Remove the drain pan according to page 2-32 and the item 2.5.7, "Removing Drain Pan".
5. Remove the heat exchanger according to page 2-32 and the item 2.5.8. "Removing Heat Exchanger and Fan Motor".
6. Cleaning
 - a. Remove dust with a brush.
 - b. Cover a vinyl sheet over the electrical components to protect them from splashed cleaning water
 - c. In the case that cleaning agent is used, clean the heat exchanger with clean water completely.
 - d. Adjust the pressure of the pump so as not to damage fins.
7. Neutralization Treatment after Cleaning
The cleaning agent specified in the item 2.10.1 is of the neutral type.
However, the cleaning water after use may be not neutral. Collect all cleaning water and make necessary neutralization treatment for the cleaning water.

NOTES:

*If the cleaning water remains, fins will be corroded.
Adjust the pressure of the pump at 2.5 to 5.0 kg/cm² so as not to damage fin*

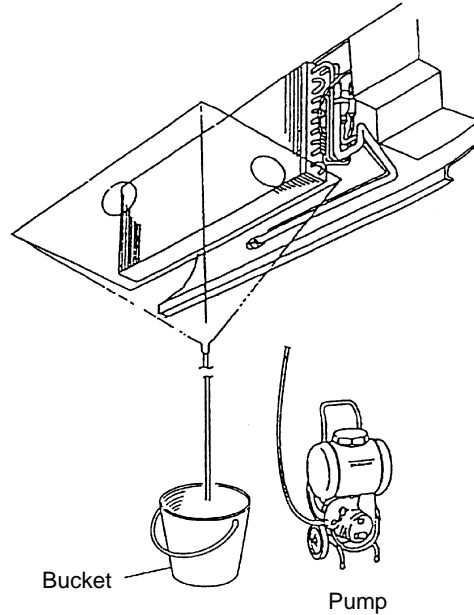

2.10.5 CLEANING FLOOR TYPE AND FLOOR CONCEALED TYPE INDOOR UNIT

■ Spread a vinyl sheet over the floor to protect furnitures, etc. from cleaning water before this work

1. Remove the front cover according to page 2-36 and the item, 2.6.4, "Removing Front Cover".
2. Disconnect the drain hose from the field-supplied pipe.
3. Cover the rear side of the heat exchanger with a vinyl sheet after removing front side partition and drain pan. After covering, remount the front side partition and drain pan.

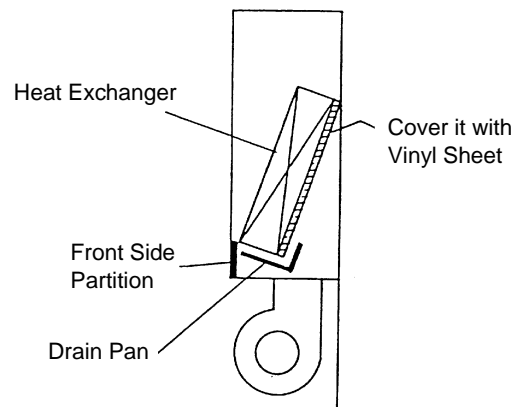

! **WARNING:** TURN OFF all power source switches

4. By lifting the drain hose and put the end in a bucket.

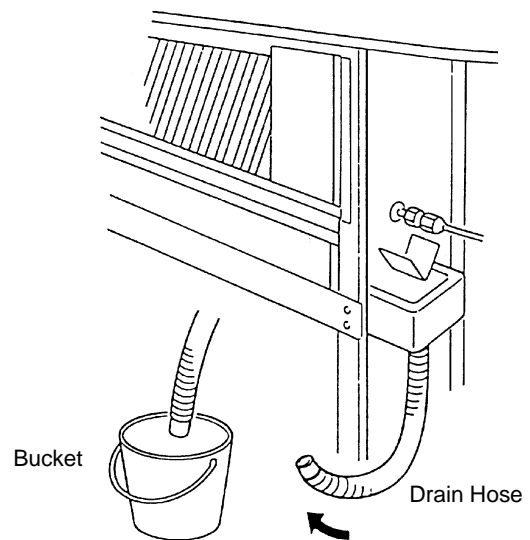

5. Removing Dust on Heat Exchanger
Remove the dust on the heat exchanger with a brush by scratching dust downwards. Collect all dust in a bucket or carton box.

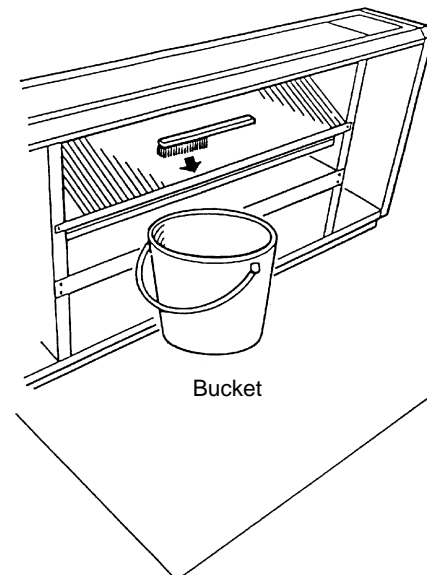

6. Spray cleaning water over the fins of the heat exchanger.

7. Cleaning with Clean Water
Cover the wiring connectors with insulation tape. Operate the pump and clean the heat exchanger with clean water completely.
Adjust the pressure of pump so as not to damage fins

NOTES:

*If the cleaning water remains, fins will be corroded.
Adjust the pressure of the pump at 2.5 to 5.0 kg/cm² so as not to damage fins.*

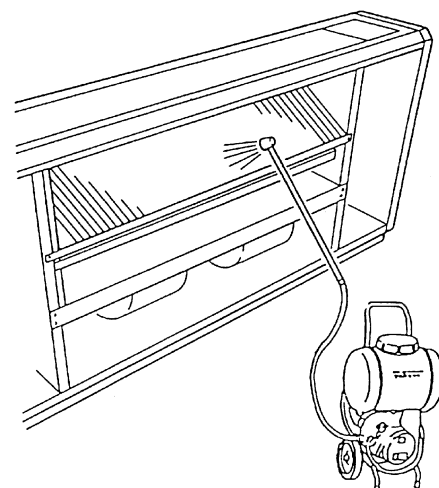

⚠ WARNING: TURN OFF all power source switches

8. After checking that no power is supplied, connect the drain pipe and remove the insulation tape for the wiring connectors and then mount the front cover correctly.
9. Check insulation of the terminal board in the electrical box. If the insulation is greater than $1M\Omega$ by a 500 Megohm-meter, it is normal.
10. Neutralization Treatment after Cleaning
The cleaning agent specified in the item, 2.10.1 is of the neutral type. However, the cleaning water after use may be not neutral. Collect all cleaning water and make necessary neutralization treatment for the cleaning water.

2.10.6 CLEANING CEILING TYPE INDOOR UNIT

■ Spread a vinyl sheet over the floor to avoid cleaning water before this work.

1. Remove the left and right side covers according to page 2-41 and the item, 2.8.2, "Removing Side Cover".
2. Remove the discharge deflector according to page 2-41 and the item, 2.8.3, "Removing Discharge Air Grille".
3. Open the intake air grille according to page 2-41 and the item, 2.8.1, "Removing Air Filter".
4. Remove the lower cover and drain pan according to page 2-44 and the item 2.8.8, "Removing Thermistors for Liquid Pipe and Gas Pipe".
5. Remove the indoor fan motor and fan assembly according to page 2-42 and 2.8.4, "Removing Fan Motor".
6. Remove the partition plate 2 after removing two fixing screws.
7. Remove the fixing plate for the fan after removing two screws at the left and one screw at the right side partition.

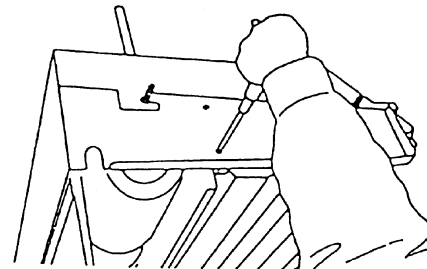
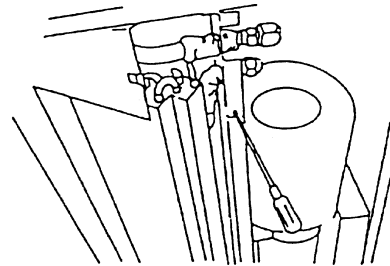

8. Attach the drain pan and lower cover according to the reverse procedures in the item, (4).
9. Cover all components except the drain pan with a vinyl sheet avoid splashed cleaning water.
10. Spray the cleaning water over the fins from the rear side of the heat exchanger. If the heat exchanger is heavily covered with dust, use a brush to wipe off.
11. Cleaning with Clean Water
 - a. Operate the pump and clean the heat exchanger with clean water completely.
 - b. Adjust pressure of the pump so as not to damage fins.

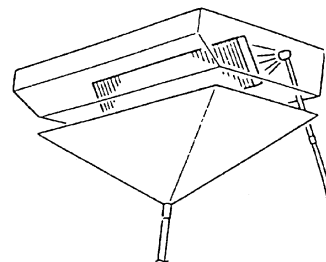

NOTES:

*Wear gloves to avoid any injury during this work due to sharp edge of fins.
If the cleaning water remains, fins will be corroded.
Adjust the pressure of the pump at 2.5 to 5.0 kg/cm² so as not to damage fins.
Pay attention to the drain pan not to overflow.*

! WARNING: TURN OFF all power source switches

12. Check insulation of the terminal board with a megohm-meter. Check to ensure that the insulation is greater than 1 M Ω when 500V is applied.
13. Check to ensure that water can flow smoothly after pouring water on the drain pan.
14. Neutralization Treatment after Cleaning
The cleaning agent specified in the item, 2.10.1 is of the neutral type. However, the cleaning water after use may be not neutral.
Collect all cleaning water and make necessary neutralization treatment for the cleaning water.

2.11 REMOVING REMOTE CONTROLER

2.11.1 REMOVING REMOTE CONTROL SWITCH

1. Remove the panel from the bracket.
 - a Snap out the bottom part of the panel from the bracket, and
 - b unhook the top part.

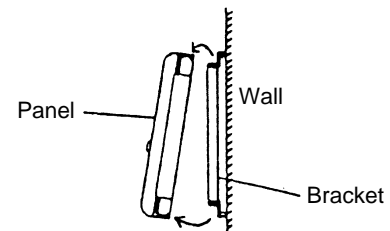

2. Remove the connector with the cable from the panel.

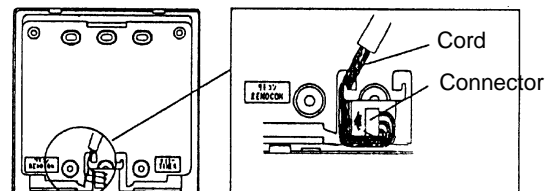

3. Disassemble the panel by removing two screws.

NOTES:

When holding the printed circuit board by hand, hold the edge and do not touch the electrical parts especially the micro-computer part. The electrical parts may be broken by the static electricity.

When reassembling, pay attention to the followings.

Blow the dust of each part away and then assembly them.

When tightening screws, pay attention not to break the plastic part.

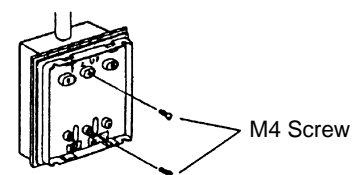

2.12 COLLECTING REFRIGERANT FOR REPLACING INDOOR UNIT

1. Prepare an empty refrigerant cylinder at -760mmHg with a charging hose. Measure the empty cylinder's weight.
2. After shutting the stop valve on the cylinder, connect the charge hose to the liquid line stop valve. Connect a pressure gauge to the check joint on the gas line stop valve.
3. Air purge inside of the hose between the liquid line stop valve and cylinder by loosening connection of the liquid line stop valve and close the connecting port of the cylinder after air purging.
4. Operate the inverter-driven compressor only as cooling mode by using dip switch, DSW7.
5. Open the liquid line stop valve on the cylinder to collect refrigerant into it. The cylinder capacity shall be equivalent to half of the total refrigerant capacity. Check the refrigerant quantity by measuring the weight.
6. Close the liquid line stop valve on the cylinder gradually during the cooling operation.
7. Fix the opening of the liquid line stop valve at a slightly opened position. Continue the cooling operation.
8. Finally close the liquid line stop valve and then gas line stop valve and stop the units at the same time when the pressure at the liquid line stop valve reaches at -400mmHg.

NOTES:

The cylinder capacity shall be equivalent to half of the total refrigerant capacity.

In case of 8HP to 20HP outdoor units;

Operate the inverter-driven compressor only by using the dip switch, DSW7.

NOTE:

In the case that the collected refrigerant is recharged into the system, charge it by let the cylinder up side down so that refrigerant and oil can be charged together.

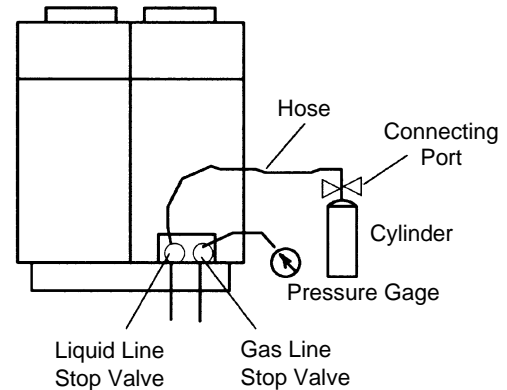

3. MAIN PARTS

3.1. INVERTER

3.1.1. CALCULATION OF OPERATING FREQUENCY

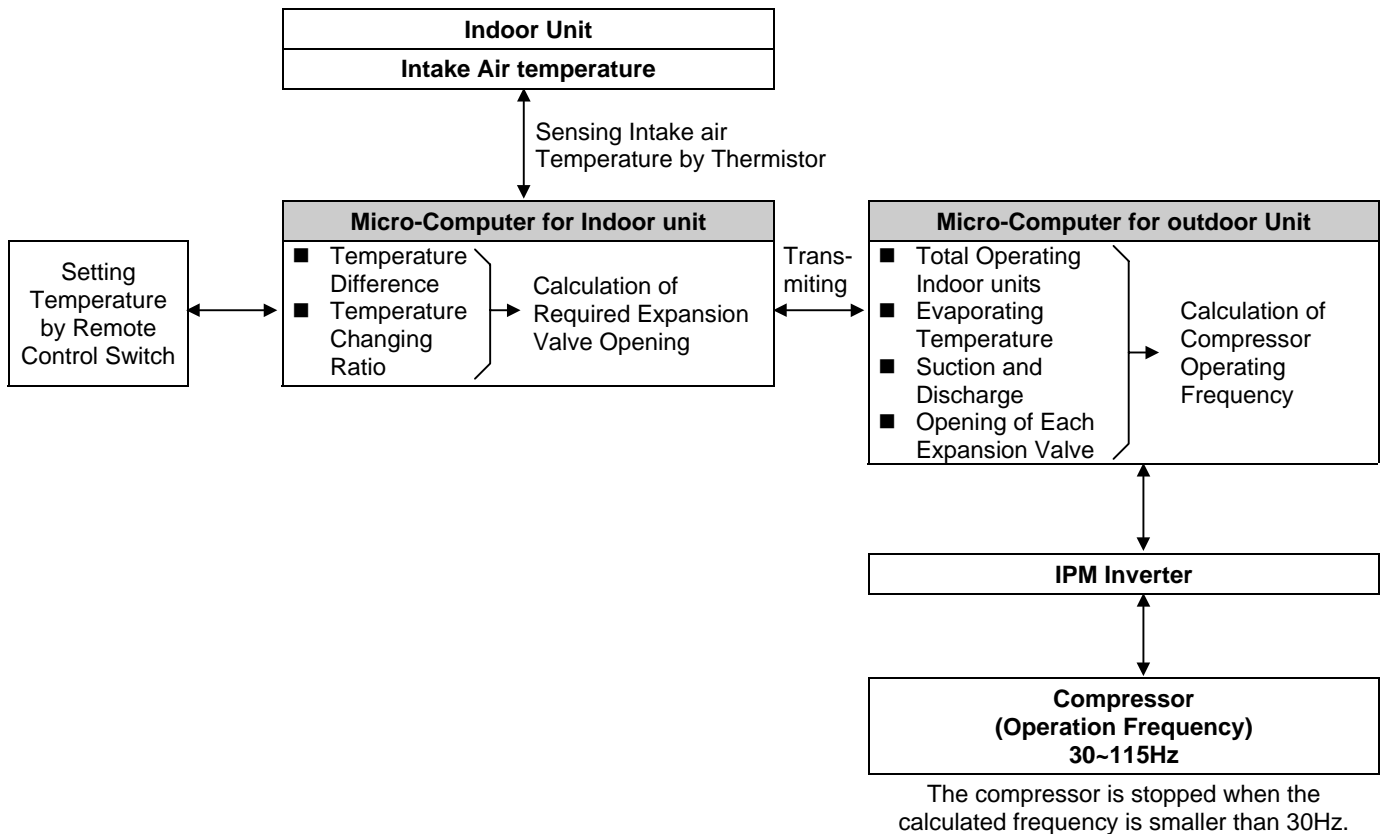

■ Control System of Refrigerant Cycle

Control subject	Purpose	
	Cooling Operation	Heating Operation
Fan Revolution of Outdoor Unit	For controlling Discharge Pressure: Pd	For Controlling Pressure Based on outdoor Air temperature
Opening Degree of Exp. V of Outdoor Unit	Fully Open	For Controlling Temperature of Discharge super-Heat: Td SH
Opening Degree of Exp. V of Indoor Unit: MV	<ol style="list-style-type: none"> For Controlling Temperature difference between Air Inlet and Air outlet of indoor Unit For Controlling Temperature Difference between Gas Pipe and Liquid pipe of Indoor Unit Heat Exchanger For Controlling Temperature of Discharge Gas Super-Heat: Td SH 	<ol style="list-style-type: none"> For Controlling Temperature difference between Air Inlet and Air outlet of indoor Unit For Balancing Temperature Differences between Air Inlet and Air Outlet of each Indoor unit
Inverter Frequency of Compressor	For Refrigerant Calculation of Total Operating Indoor Units	For Refrigerant Calculation of Total Operating Indoor Units

3.1.2. SPECIFICATIONS OF INVERTER

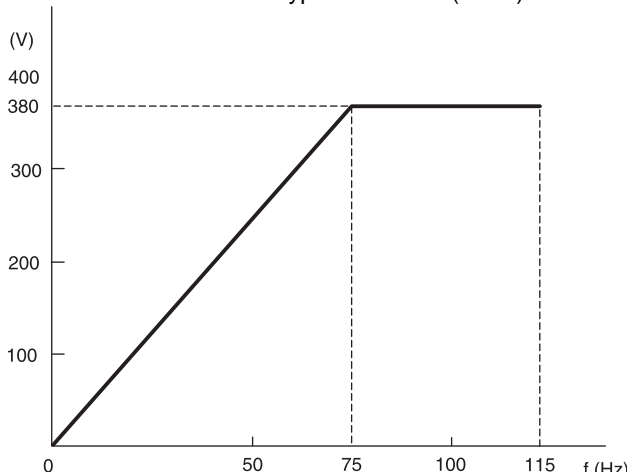
Applicable Models	RAS-5FSG, RAS-5FS3, RAS-8FSG, RAS-8FS3, RAS-10FSG, RAS-10FS3, RAS-16FSG, RAS-16FS3, RAS-20FSG, RAS-20FS3
Applicable Power Source	3 Phase 380 / 415V \pm 10% 50Hz \pm 5%
Output Voltage (Maximum)	380 / 415V, 3 Phase
Output Current (Maximum)	14.0A (5,8 and 10HP) / 16.5A (16 and 20HP)
Time Rating	Continuous
Control Method	Frequency \leq 75Hz, Space Vector PWM Control 75Hz < Frequency \leq 115Hz, V/F Control
Range Output Frequency	30~95Hz (5HP), 30~115Hz (8,10, 16 and 20HP)
Accuracy of Frequency	0.005Hz at Applicable Frequency Range
Controlled Frequency	0.01Hz
Accuracy of Output Voltage	\pm 10% at Applicable Frequency Range
Output / Characteristics	<p>Conditons: 1. Power Source Voltage AC380/415V 2. Non-Loading (Free Output) 3. Ammeter Type Volt-Meter (\times 1.1)</p>  <p>Refer to the follow note</p>
Soft Start-Stop	0.5Hz/S, 1Hz/S, 3Hz/S, 6Hz/S, 30Hz/S (5 Steps)
Protection Function	
Excessive High or Low Voltage for Inverter	Excessive Low Voltage at a Voltage is lower than 350V Excessive High Voltage at a Voltage is higher than 750V
Abnormality of Current Sensor	Stoppage at a current of compressor smaller than 0.5A When the frequency is 15~18Hz after starting. Cause of Abnormality: Failure of current Sensor Failure of transistor module Failure of compressor Disconnected wiring

NOTE:

Characteristics are fluctuated by the current minimize control.

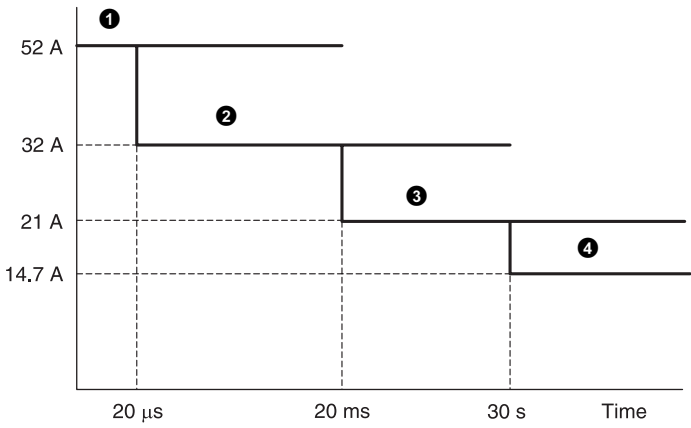
<p>Protection Function</p> <p>Overcurrent Protection for Inverter</p>	 <p> ① Short-circuit Trip of Arm (Internal Protection of Transistor Module) ② Instantaneous Overcurrent Trip (Internal Protection of Transistor Module) ③ Instantaneous Overcurrent Trip ④ Electronic Thermal Trip Condition is maintained longer than 30 seconds or accumulated longer than 3.5 minutes during 10 minutes sampling time. </p>
<p>Protection of Transistor Module</p>	<p>Transistor module has four protection function for self-protection.</p> <p> ① Some of the output terminals between "U" and "V", "V" and "W", "W" and "U" has a short-circuit ② Running current reaches the maximum rated current. ③ Temperature is measured by internal thermistor exceeds 150°C. ④ Control voltage decreases to 12.5V </p>
<p>overload Control</p>	<p>Overload control at a current greater than (Rated current × 105%) Overload control release at a current smaller than (Rated current × 88%)</p>

NOTE:
 Characteristics are fluctuated by the current minimize control.

3.1.3. ARRANGEMENT OF INVERTER POWER UNIT

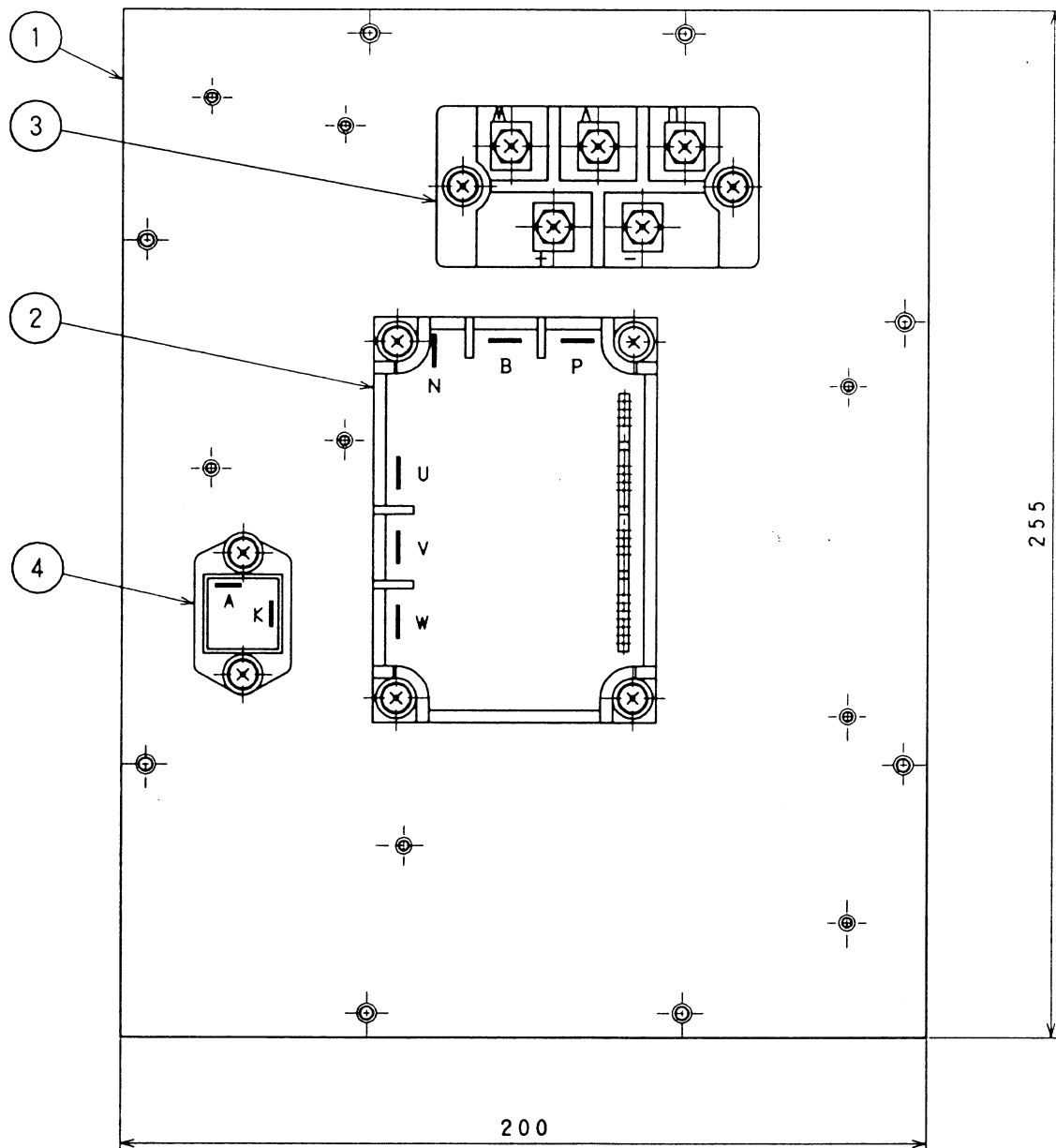

No.	Parts	Model	Name
		380 / 415V, 50Hz	
1	Fin (mm)	(200 × 255 × 50)	-
2	Transistor Module	PM25RSB120	IPM
3	Diode Module	DF40AA160	DM
4	Diode Module	RM201-1A-20F	D

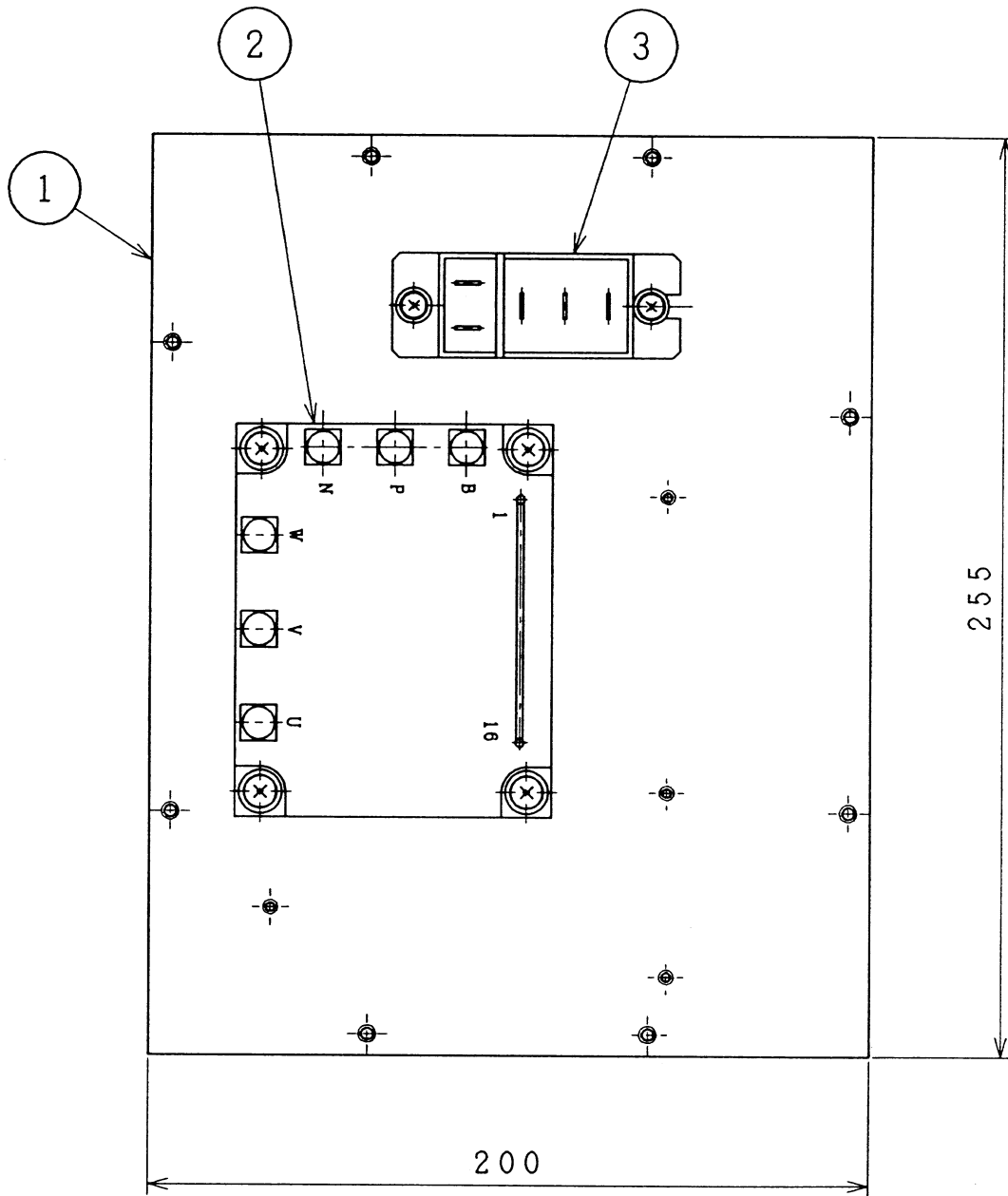

No.	Parts	Model	Name
		380 / 415V, 50Hz	
1	Fin (mm)	(200 × 255 × 50)	-
2	Transistor Module	6MBP25RA120-05	IPM
3	Diode Module	6RI30G-160	DM

3.1.4. INVERTER TIME CHART

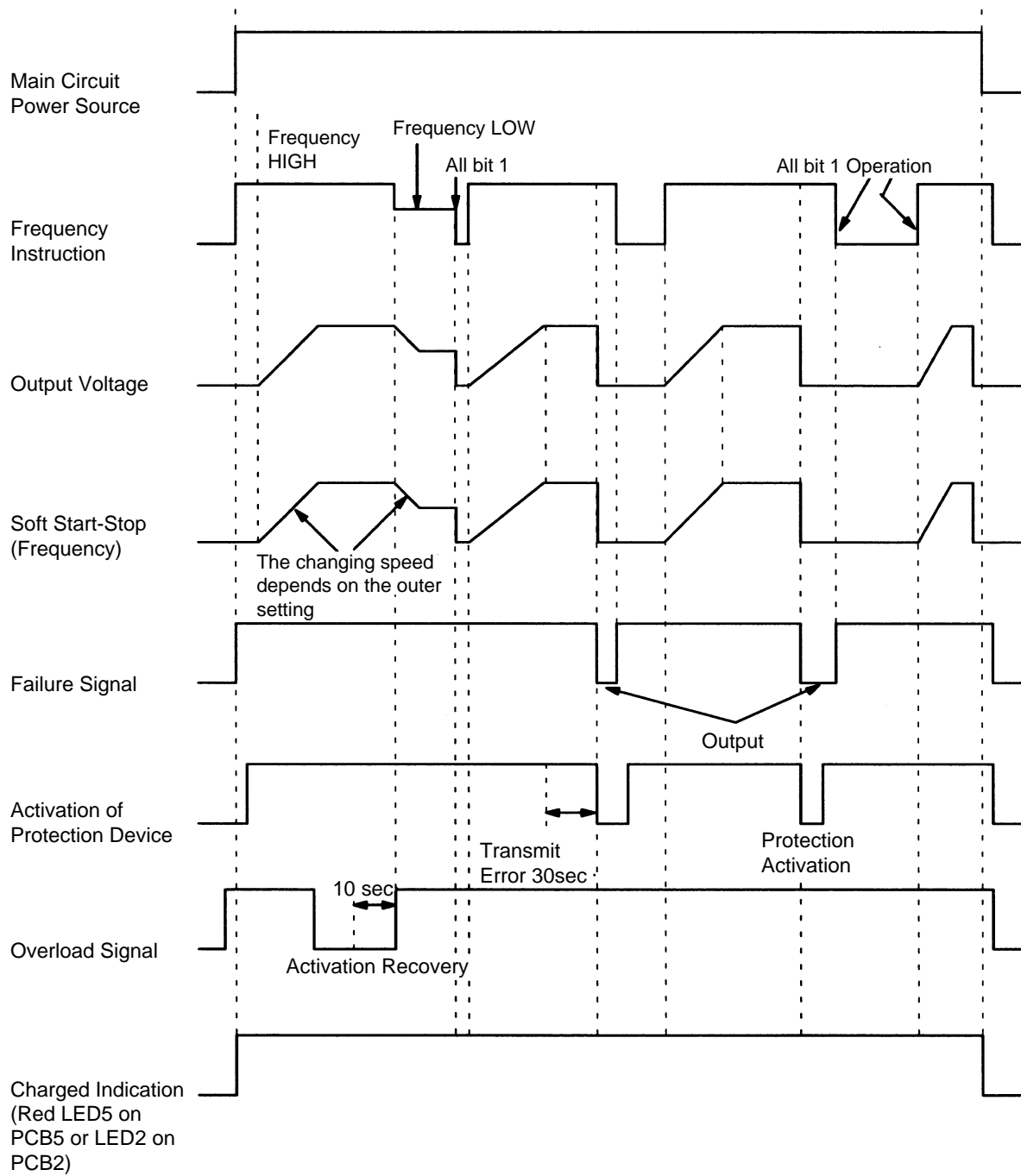

3.1.5. PROTECTIVE FUNCTION

■ Excessive High or Low Voltage for Inverter

- a. Level of Detection
 1. When the voltage of direct current is greater than 750V, abnormalities are detected.
 2. When the voltage of direct current is smaller than 350V, abnormalities are detected.
- b. Function
When abnormalities are detected, the inverter compressor is stopped and transmit the signal code of stoppage cause to PCB1.
- c. Cancellation of Protection Function Transmission for signal code of stoppage cause is cancelled when a stopping order is given or main power source is cut off.

■ Abnormality of Current Sensor

- a. Level of Detection
When current of the inverter compressor decreases lower than 0.5 A during the inverter compressor frequency between 15Hz and 18Hz, an abnormality is detected.
- b. Function
When abnormalities are detected, the inverter compressor is stopped, and transmit the signal code of stoppage cause to PCB1.
- c. Cancellation of Protection Function Transmission for signal code of stoppage cause is cancelled when a stopping order is issued or main power source is cut off.

■ Overcurrent Protection for Inverter

- a. Level of Detection
 1. When the current detected by current sensor reaches 150% of the rated current, overcurrent is detected. (Instantaneous Overcurrent)
 2. When the current detected by current sensor exceeds 105% of the rated current continuously for 30 seconds or for 3.5 minutes in total during a 10 minutes period, overcurrent is detected. (Electric Thermal Relay)
- b. Function
When abnormalities are detected, the inverter compressor is stopped and transmit the signal code of stoppage cause to PCB1.
- c. Cancellation of Protection Function Transmission for signal code of stoppage cause is canceled by stopping order is issued or main power source is cut off.

■ Protection of Transistor Module

- a. Level of Detection
 1. When some of the output terminals between "U" and "V", "V" and "W", "W" and "U" of transistor module are short-circuited, an abnormality is detected.
 2. When the running current of transistor module reaches (Maximum Rated Current × 105%), an abnormality is detected.
 3. When an internal temperature is measured by internal thermistor of transistor module exceeds 150°C, an abnormality is detected.
 4. When the control voltage of transistor module decreases to 12.5V, an abnormality is detected.
- b. Function
When abnormalities are detected, the inverter compressor is stopped and the signal code of stoppage cause is transmitted to PCB1.
- c. Cancellation of Protection Function Transmission for signal code of stoppage cause is canceled when a stopping order is issued or main power source is cut off.

■ Overload Control

- a. Level of Detection
When the output current exceeds 105% of the maximum output current, an abnormality is detected.
- b. Function
An overload signal is issued when output current exceeds 105% of the maximum output current, and the frequency decreases at a rate of 0.5Hz/s. For 10 seconds after the output current decreases lower than 88% of the rated current, the operation is performed with the compressor frequency limited to the upper level frequency when the output current decreases lower than 88% of the rated one. However, if the frequency order is smaller than the maximum value, the operation is performed according to the order.
- c. Cancellation of Protection Function After the operation described in the above item b. is performed for 10 seconds, this control is canceled.

3.2. THERMISTOR

Thermistors for Outdoor Unit

Thermistor for discharge Gas Temperature (THM8 for Inverter Compressor, THM9, THM12 and THM13 for Constant Speed Compressor)

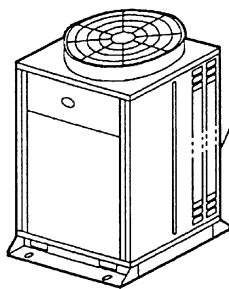
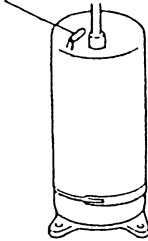

Thermistor for Outdoor Ambient temperature (THM7)

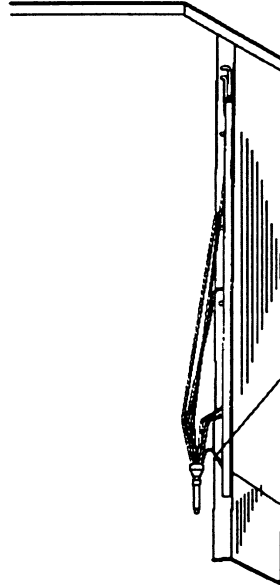

Thermistor for Evaporating temperature (THM10 and THM11)

Thermistors for Indoor Unit

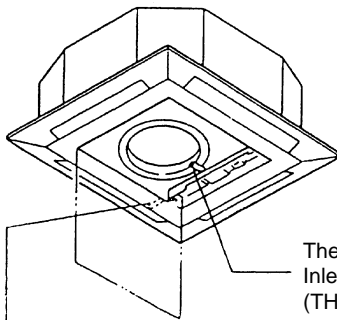

Thermistor for Air Outlet Temperature (THM2)

Thermistor for Air Inlet Temperature (THM1)

Thermistor for Indoor Heat Exchanger Gas Pipe Temperature (THM5)

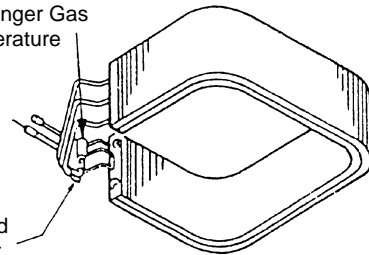

Thermistor for Indoor Heat Exchanger Liquid Pipe Temperature (for Freeze Protection) (THM3)

3.2.1. RESISTANCE VALUE OF THERMISTOR

■ Discharge Gas Overheating Prevention (Thermistor for Checking Upper Part of Compressor, THM8, THM9, THM12 and THM3)

- a. A thermistor checking the temperature of the compressor upper part is installed, to prevent discharge gas from overheating. If discharge gas temperature increases excessively lubricating oil deterioration occurs and lubricating properties deteriorate, resulting in short compressor life.
- b. If discharge gas temperature increases excessively, compressor temperature increases. At the worst, compressor motor winding will be burnt out.
- c. When the compressor upper part temperature increases during heating operation, the unit is controlled according to the following method.
 1. An electronic expansion valve of liquid bypass opens and high pressure refrigerant is returned to the compressor through the accumulator, decreasing compressor temperature.
 2. If the compressor upper part temperature increases exceeding 127 °C for 10 minutes even if an electronic expansion valve opens, the compressor is stopped, in order to protect the compressor. Thermistor resistance characteristics are shown in Fig. 3.1.
- d. If compressor upper part temperature increases exceeding 127 °C for 10 minutes during cooling operation, the compressor is stopped. (Refer to the block diagram for details.)

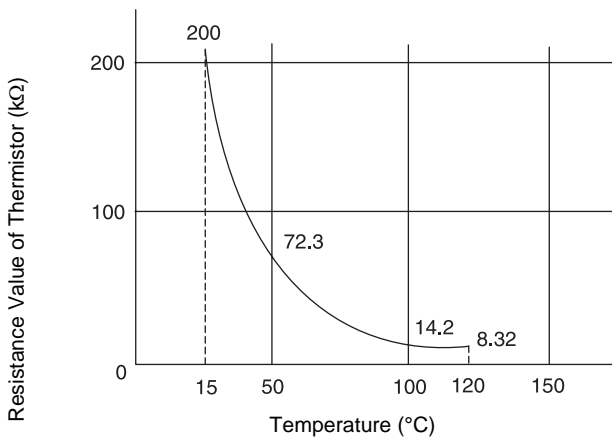

Fig. 3.1 Resistance Characteristics of Thermistor for Discharge Gas Overheating protection

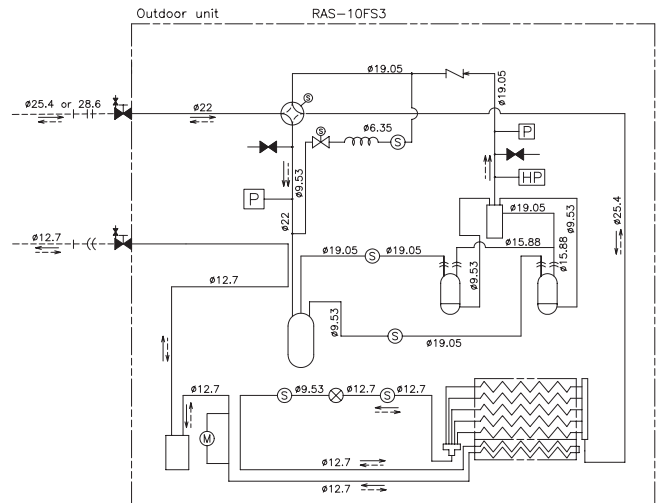

Fig. 3.2 Refrigeration Cycle of Outdoor unit (RAS-10FS3)

■ Thermistor for Outdoor Ambient Temperature (THM7)

When outdoor temperature decrease to -8 °C or lower, the compressor is stopped, during cooling operation. Thermistor resistance characteristics are shown in Fig. 3.3.

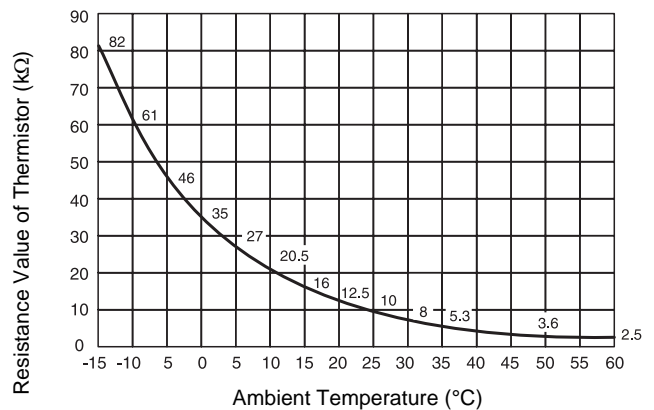

Fig. 3.3 Refrigeration Cycle of Outdoor unit (RAS-10FS3)

■ Thermistor for Defrosting (THM10, THM11)

The characteristics for the thermistor is the same with the value of outdoor ambient temperature thermistor.

■ Thermistor for Room Temperature Control (Indoor Unit Air Inlet Temperature Thermistor, THM1)

The room temperature control is performed by this air inlet temperature thermistor, THM1. The setting temperatures are indicated on the remote control switch with figures. Set room temperature so that room temperature does not become too cool or too hot. We recommend that temperature be set in the following ranges.

Economical Cooling Operation: 27°C to 29 °C

Economical Heating Operation: 18 °C to 20 °C

The resistance characteristics of the thermistor is shown in Fig. 3. 4

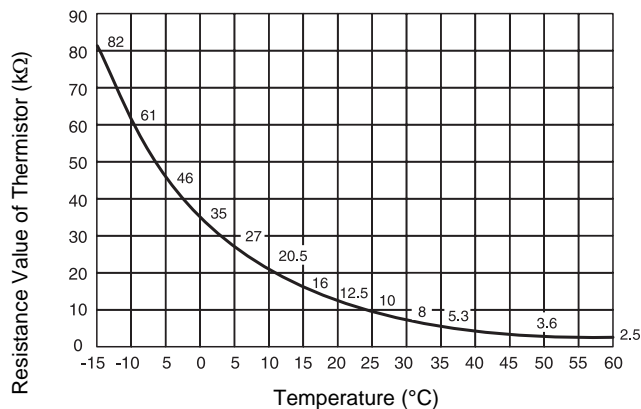

Fig. 3. 4 Resistance Characteristics of Thermistor for Air Inlet Temperature

▲ CAUTION:

The thermo-off valve of the indoor unit air inlet thermistor is set at the temperature higher than the value indicated on the remote control switch by 4 °C and the maximum is 34 °C, because suction air temperature during heating operation has a tendency to become higher than that of the occupied zone, intending comfortable heating operation.

■ Thermistor for Discharge Air Temperature Control (Indoor Unit Discharge Air Temperature Thermistor, THM2)

This thermistor (THM2) has been installed to prevent cold blow during heating operation. The characteristics of the thermistor resistance is shown in Fig. 3. 4

■ Thermistor for Liquid Pipe of Indoor Heat Exchanger

When the temperature of the indoor heat exchanger decreases to 0 °C or lower for 3 minutes, the thermostat is automatically turned off. When the temperature increase to 16 °C or higher, the thermostat is turned on.



The purpose of this function is to prevent frosting on the heat exchanger during cooling operation and dry operation. The characteristics of the thermistor resistance is shown in Fig. 3. 4

■ Thermistor for Gas Pipe of Indoor Heat Exchanger

This thermistor senses the evaporating temperature during heating operation. The characteristics of the thermistor resistance is shown in Fig. 3. 4

3.3. ELECTRONIC EXPANSION VALVE

3.3.1. ELECTRONIC EXPANSION VALVE FOR OUTDOOR UNITS

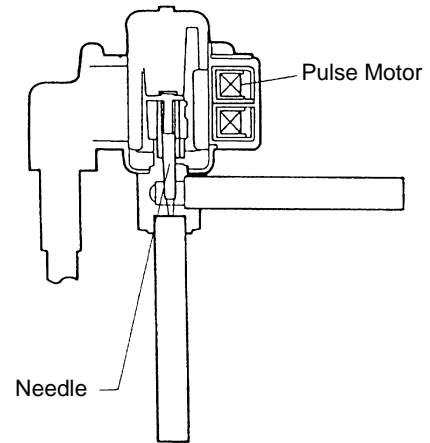
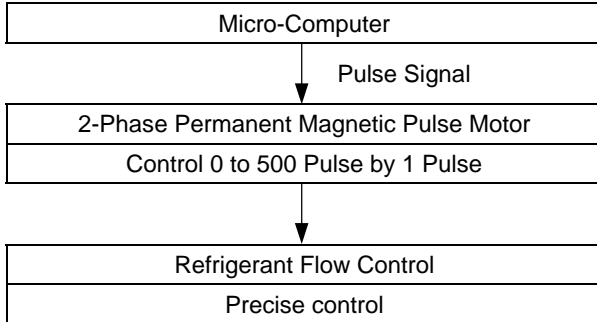

Items	Specifications
Models to be Applied	For Main Cycle of: RAS-5FSG, RAS-5FS3, RAS-8FSG, RAS-8FS3, RAS-10FSG, RAS-10FS3, RAS-16FSG, RAS-16FS3, RAS-20FSG, RAS-20FS3
Type	EKV (10.0USRT) Series
Refrigerant Used	R22 or R407
Working Temperature Range	-30 °C ~ 65 °C (Operating Time of Coil: less than 50%)
Mounting Direction	Drive shaft in Vertical Direction within an Angle of 45° as Maximum
Flow Direction	Reversible
Drive Method	4-Phase Canned Motor Method
Rated Voltage	DC12V±1.8V
Drive Condition	83PPS (Pulse Width at ON: 36mm sec, OFF:60mm sec) 1,2 Phase Excitation
Coil Resistance (each Phase)	46Ω ± 10% (at 20 °C)
Wiring Diagram, Drive Circuit And Activation mode	

3.3.2. ELECTRONIC EXPANSION VALVE FOR INDOOR UNITS

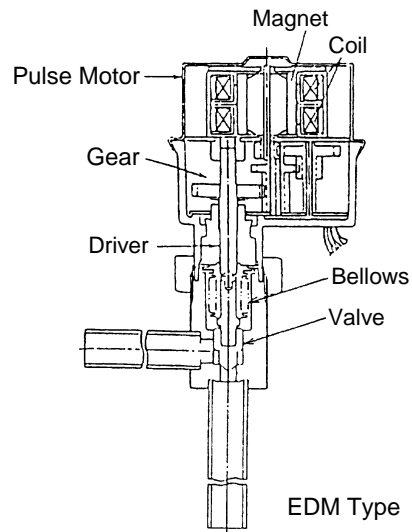
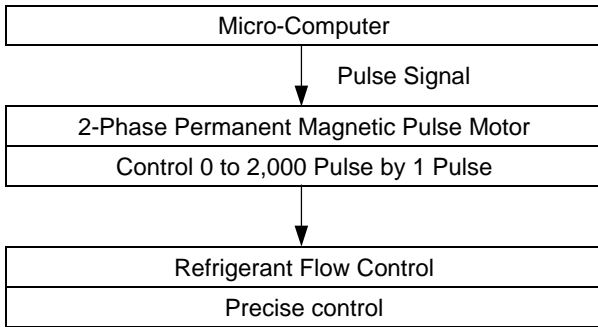

Items	Specifications																																										
Type	EDM Type																																										
Refrigerant Used	R22 or R407																																										
Working Temperature Range	-30 °C ~ 70 °C (With Coils not Electrified)																																										
Mounting Direction	Drive shaft in Vertical Direction, Motor Upside and 90° in Four Direction																																										
Flow Direction	Reversible																																										
Rated Electricity																																											
Drive Method	4-Phase Pulse Motor																																										
Rated Voltage	DC12V±1.2V																																										
Drive Condition	100Ω ± 250PPS (Pulse Width Over 3mm) 2 Phase Excitation																																										
Coil Resistance (each Phase)	150Ω ± 10% (at 20 °C)																																										
Wiring Diagram, Drive Circuit And Activation mode	<table border="1"> <thead> <tr> <th>Process-Phase</th> <th>1</th> <th>2</th> <th>3</th> <th>4</th> <th>1</th> </tr> </thead> <tbody> <tr> <td>1φ ON</td> <td>[Pulse]</td> <td>[Low]</td> <td>[Low]</td> <td>[Low]</td> <td>[Pulse]</td> </tr> <tr> <td>1φ OFF</td> <td>[Low]</td> <td>[Pulse]</td> <td>[Low]</td> <td>[Low]</td> <td>[Low]</td> </tr> <tr> <td>2φ</td> <td>[Low]</td> <td>[Pulse]</td> <td>[Pulse]</td> <td>[Low]</td> <td>[Low]</td> </tr> <tr> <td>3φ</td> <td>[Low]</td> <td>[Low]</td> <td>[Pulse]</td> <td>[Pulse]</td> <td>[Low]</td> </tr> <tr> <td>4φ</td> <td>[Low]</td> <td>[Low]</td> <td>[Low]</td> <td>[Pulse]</td> <td>[Pulse]</td> </tr> <tr> <td>Valve Activation</td> <td colspan="5"> ← Close Open → </td> </tr> </tbody> </table> <p style="text-align: center;">Activation Mode</p>	Process-Phase	1	2	3	4	1	1φ ON	[Pulse]	[Low]	[Low]	[Low]	[Pulse]	1φ OFF	[Low]	[Pulse]	[Low]	[Low]	[Low]	2φ	[Low]	[Pulse]	[Pulse]	[Low]	[Low]	3φ	[Low]	[Low]	[Pulse]	[Pulse]	[Low]	4φ	[Low]	[Low]	[Low]	[Pulse]	[Pulse]	Valve Activation	← Close Open →				
Process-Phase	1	2	3	4	1																																						
1φ ON	[Pulse]	[Low]	[Low]	[Low]	[Pulse]																																						
1φ OFF	[Low]	[Pulse]	[Low]	[Low]	[Low]																																						
2φ	[Low]	[Pulse]	[Pulse]	[Low]	[Low]																																						
3φ	[Low]	[Low]	[Pulse]	[Pulse]	[Low]																																						
4φ	[Low]	[Low]	[Low]	[Pulse]	[Pulse]																																						
Valve Activation	← Close Open →																																										

3.4. PRESSURE SENSOR

■ High Pressure Control

The high pressure during heating operation is detected by a high pressure sensor, and compressor frequencies are controlled by the proportional controlling method with operating capacity of indoor units so that the high pressure is controlled in an appropriate range. The output of the high pressure sensor during heating operation performs protective control; gas by-pass control.

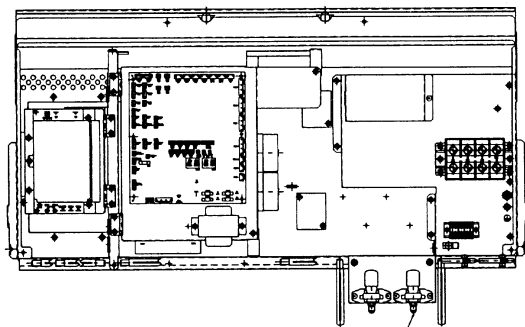

High Pressure Sensor

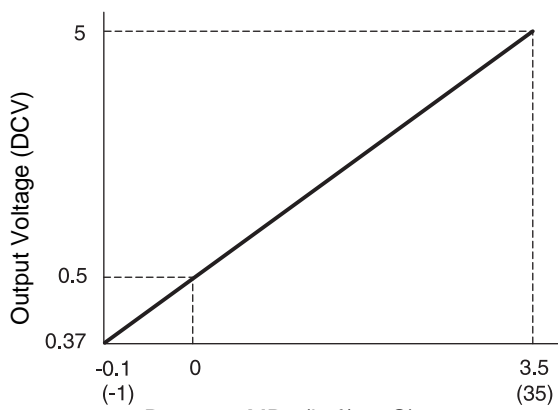
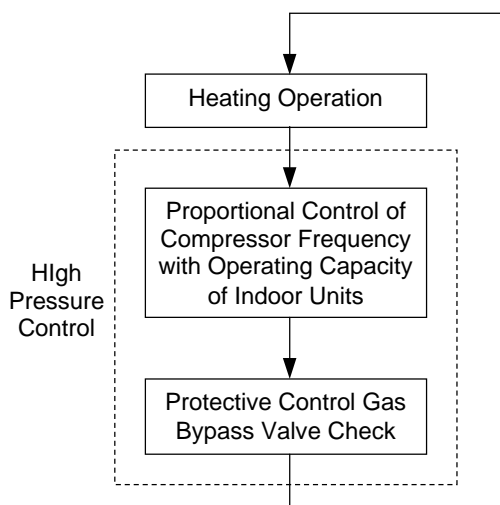

Output Characteristics of High Pressure Sensor

■ Low Pressure Control

The suction pressure during cooling operation is detected by a low pressure sensor, and compressor frequencies are controlled by the proportional controlling method with operating capacity of indoor units so that the suction pressure is controlled in an appropriate range. If the suction pressure reaches excessively low, the cooling can be insufficient and parts composing the refrigeration cycle can be damaged. For this reason, if the output of the low pressure sensor indicates vacuum and the valve is maintained 12 minutes or longer, the compressor is stopped for the purpose of protection.

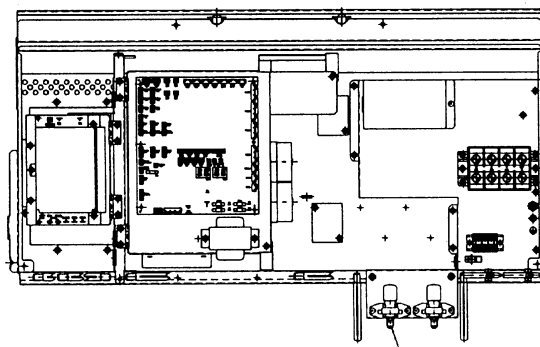

Low Pressure Sensor

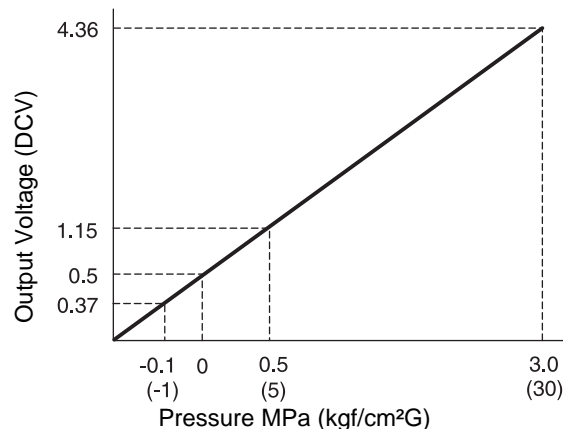
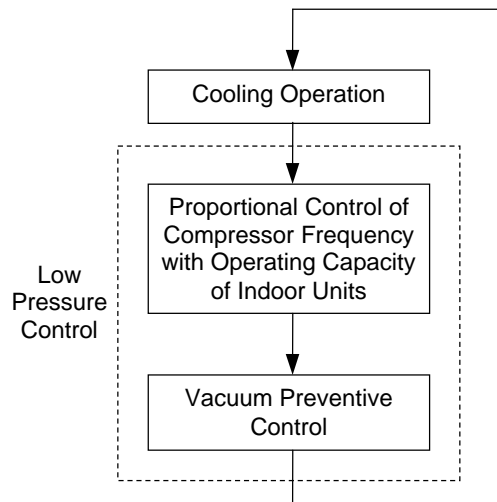

Output Characteristics of Low Pressure Sensor

3.5. NOISE FILTER

The noise filter decreases the leakage of noise made by the inverter to the power supply side.

Terminals indicated with "OUT" are connected to the inverter side and terminals indicated with "IN" to the power supply side.

Specifications

Items	Specifications
Model	HF4020-DV
Rated current	AC415V 20A
Permissible Temperature Range	-20 °C ~ 65 °C
Circuit Diagram	

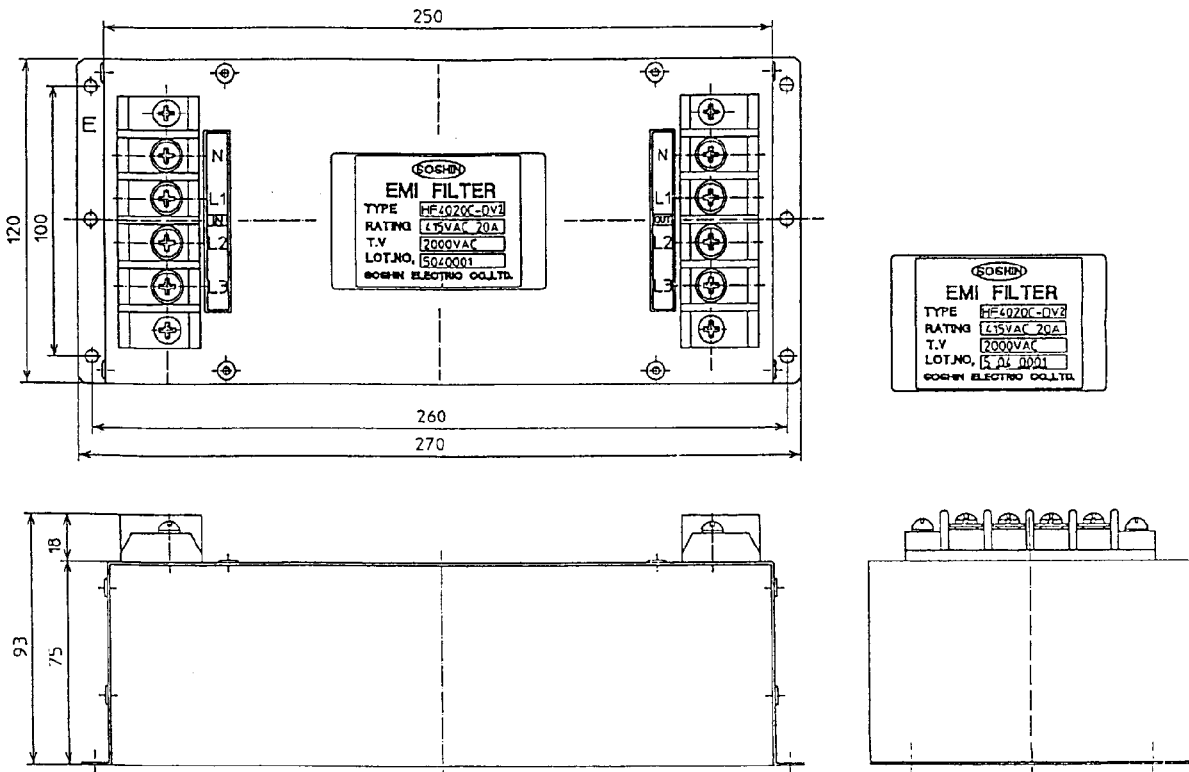

Items	Specifications
Model	20PTT10-H
Rated current	AC415V 20A
Permissible Temperature Range	-20 °C ~ 85 °C
Circuit Diagram	

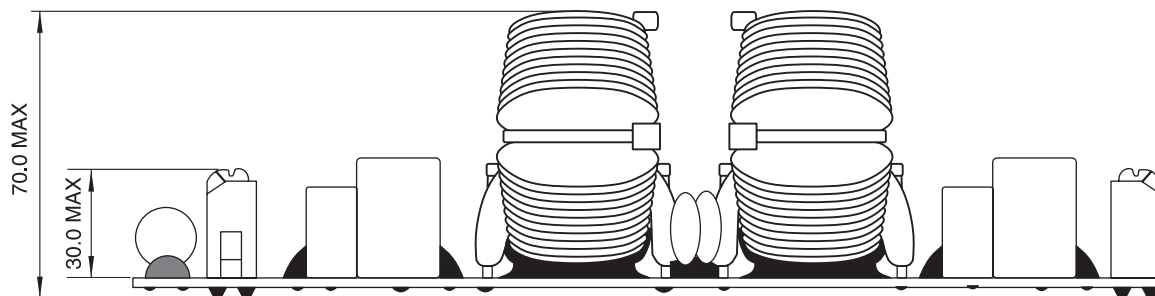
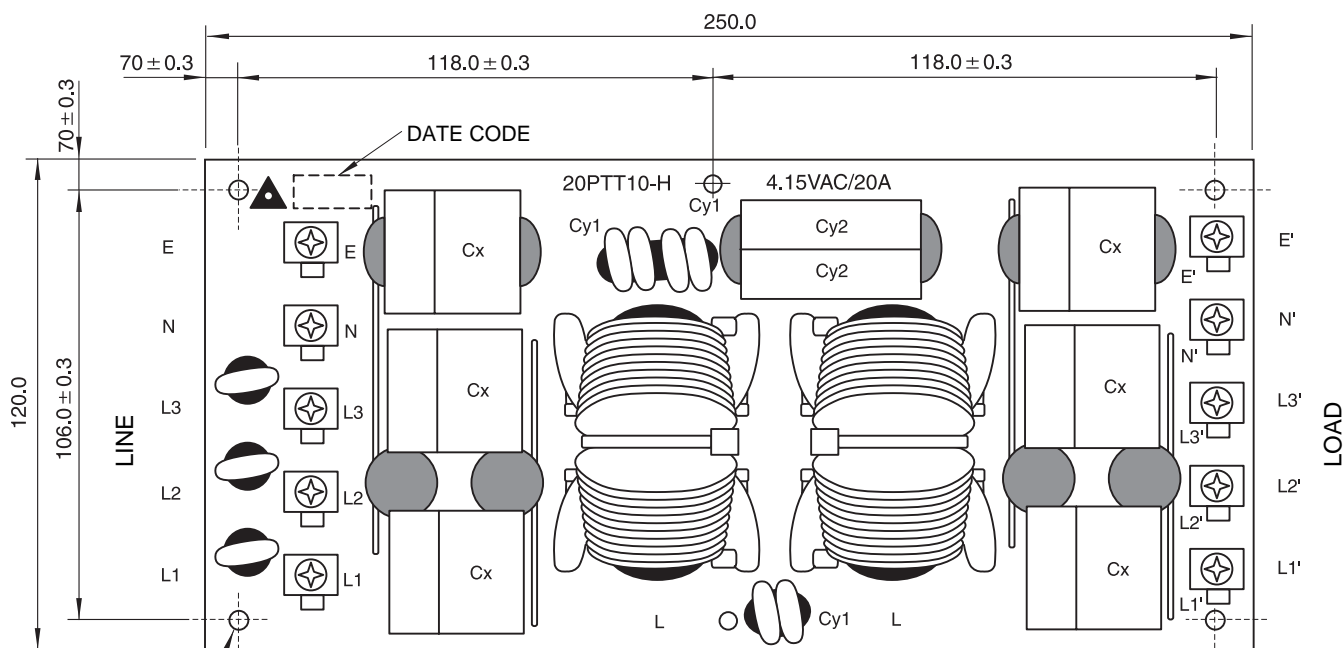

Units: mm

3.6. CAPACITOR

This part is used for changing the alternative current to the direct current for the inverter. Connect two capacitor in line and used.

Specifications

Items	Specifications
Model	400LGN2700M
Capacity of Static Electricity	2700 μ F
Rated Voltage	400V
Permissible Temperature Range	-20 °C ~ 95 °C

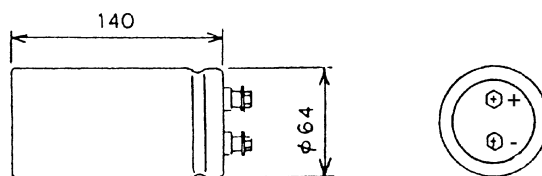

3.7. REACTOR (DCL)

This part is used for changing the alternative current to the direct current for the inverter.

Specifications

Items	Specifications
Character	1mH \pm 10% (at 1kHz)
Rated current	33A
Direct Resistance	25.1m Ω \pm 20% (at 20°C)
Permissible Temperature Range	-20 °C ~ 60 °C

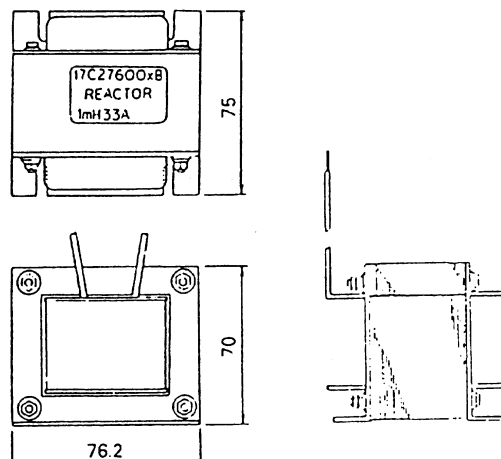

Items	Specifications
Character	0.5mH \pm 10% (at 1kHz)
Rated current	37A
Direct Resistance	12.2m Ω \pm 20% (at 20°C)
Permissible Temperature Range	-20 °C ~ 65 °C

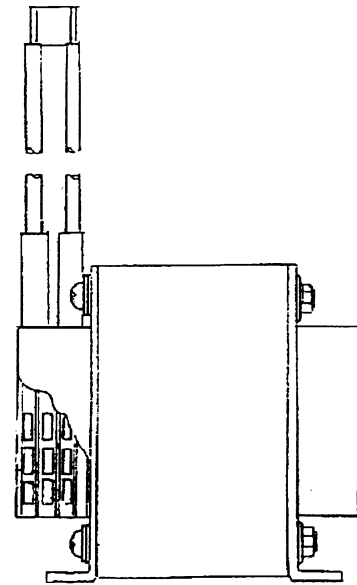
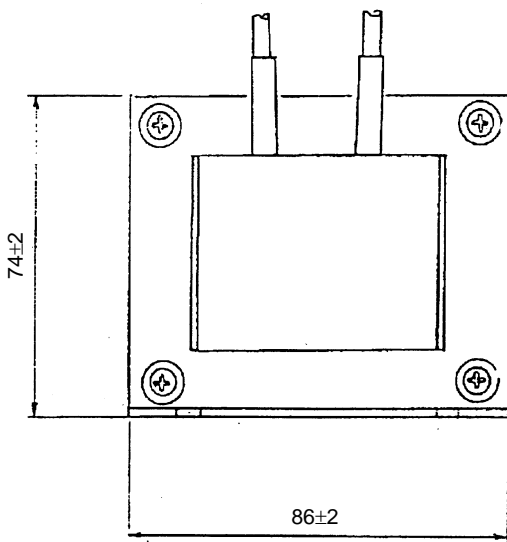
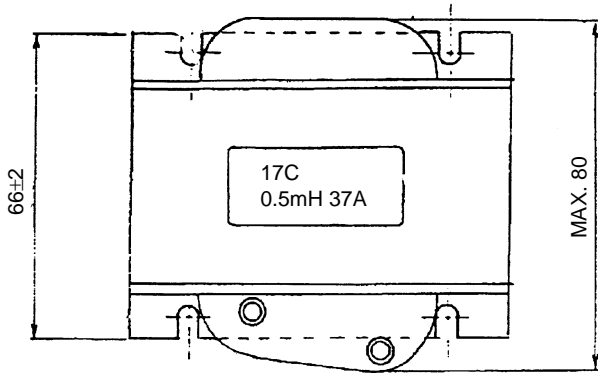

3.8. CIRCUIT DIAGRAM FOR PRINTED CIRCUIT BOARD OF OUTDOOR UNIT

■ Control Board 1: PCB1 (1/2)

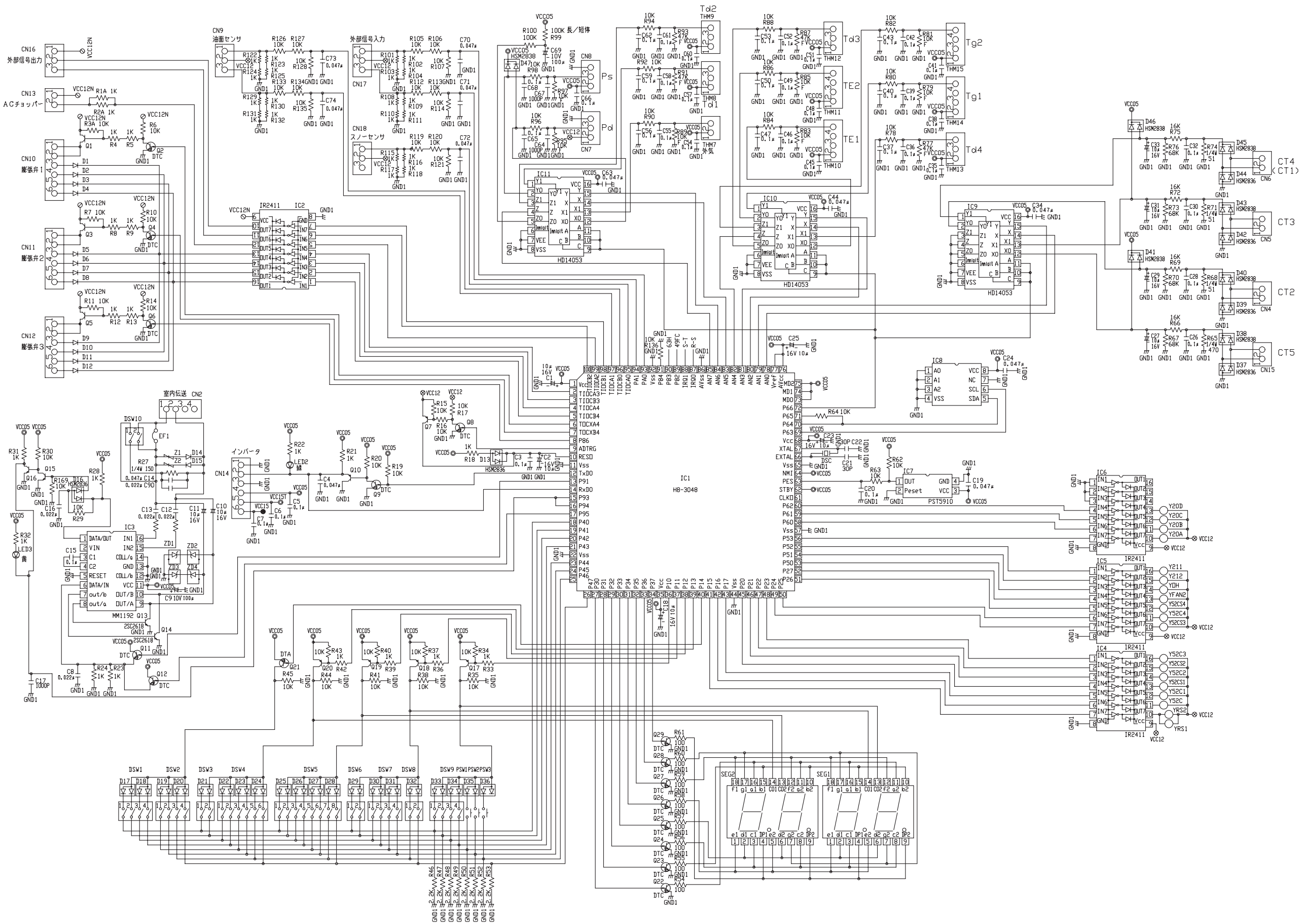

Control board 1: PCB1 (2/2)

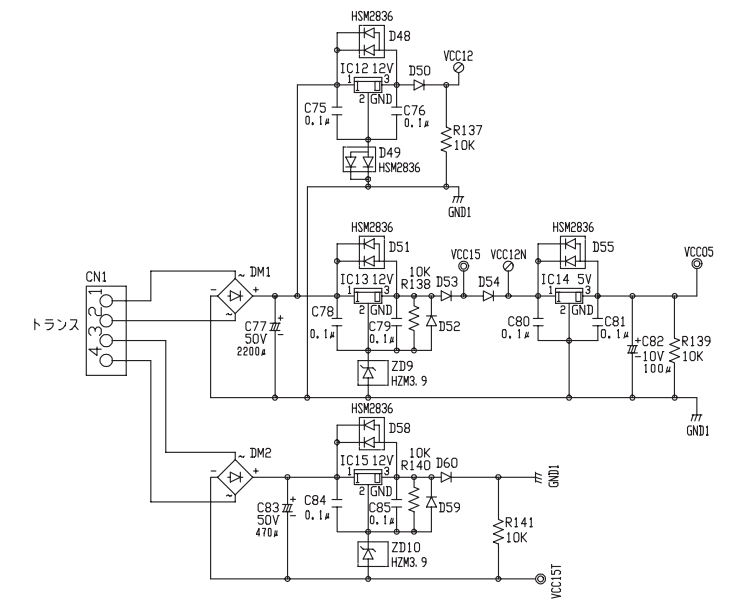
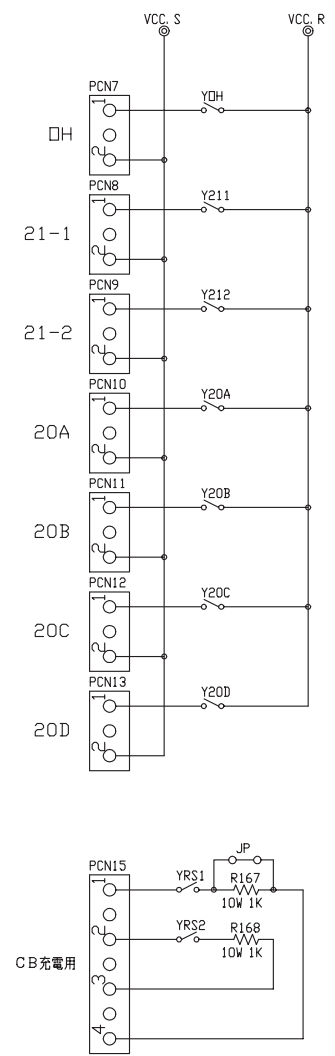
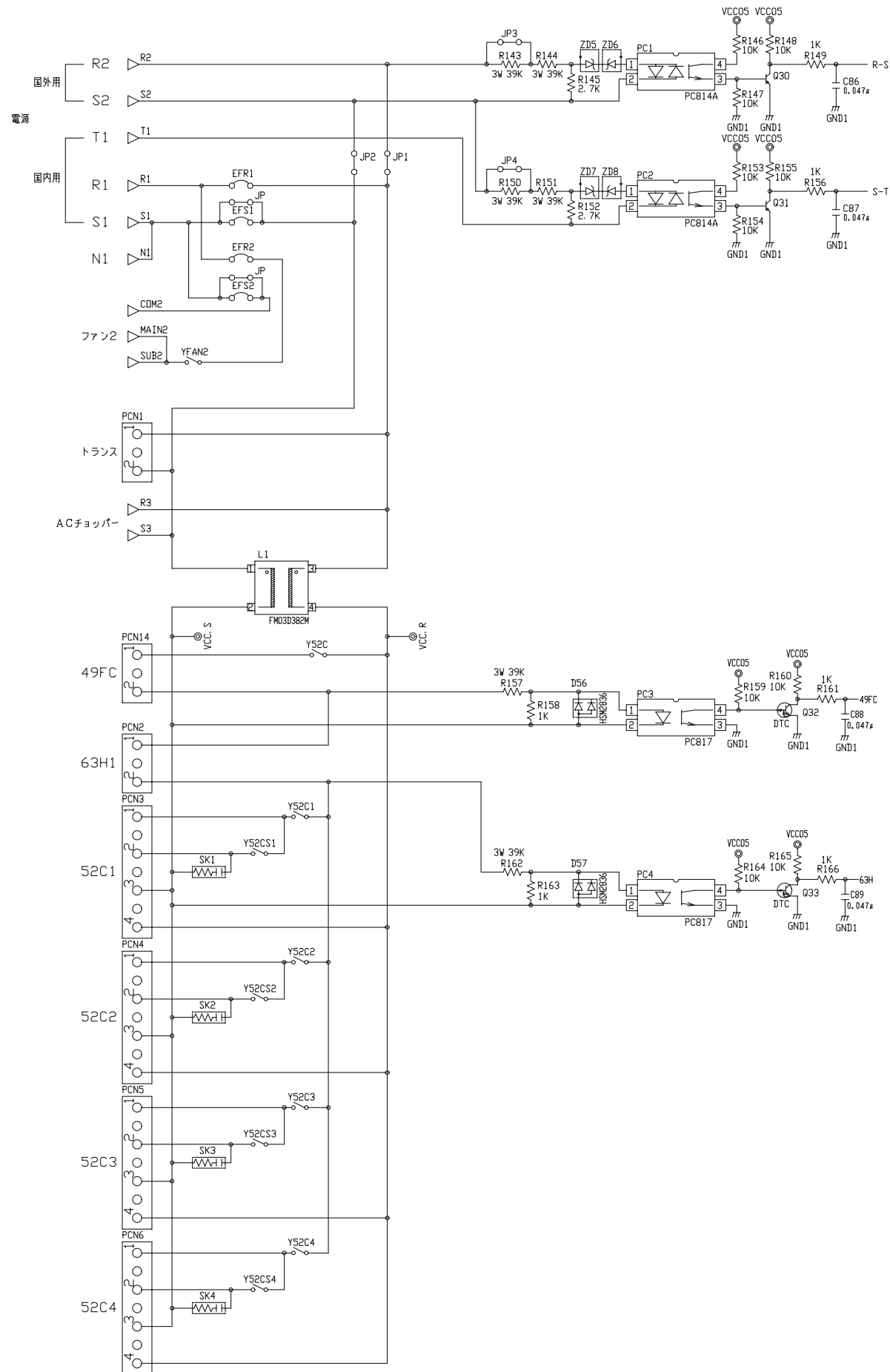

■ Fan Control Board: PCB2

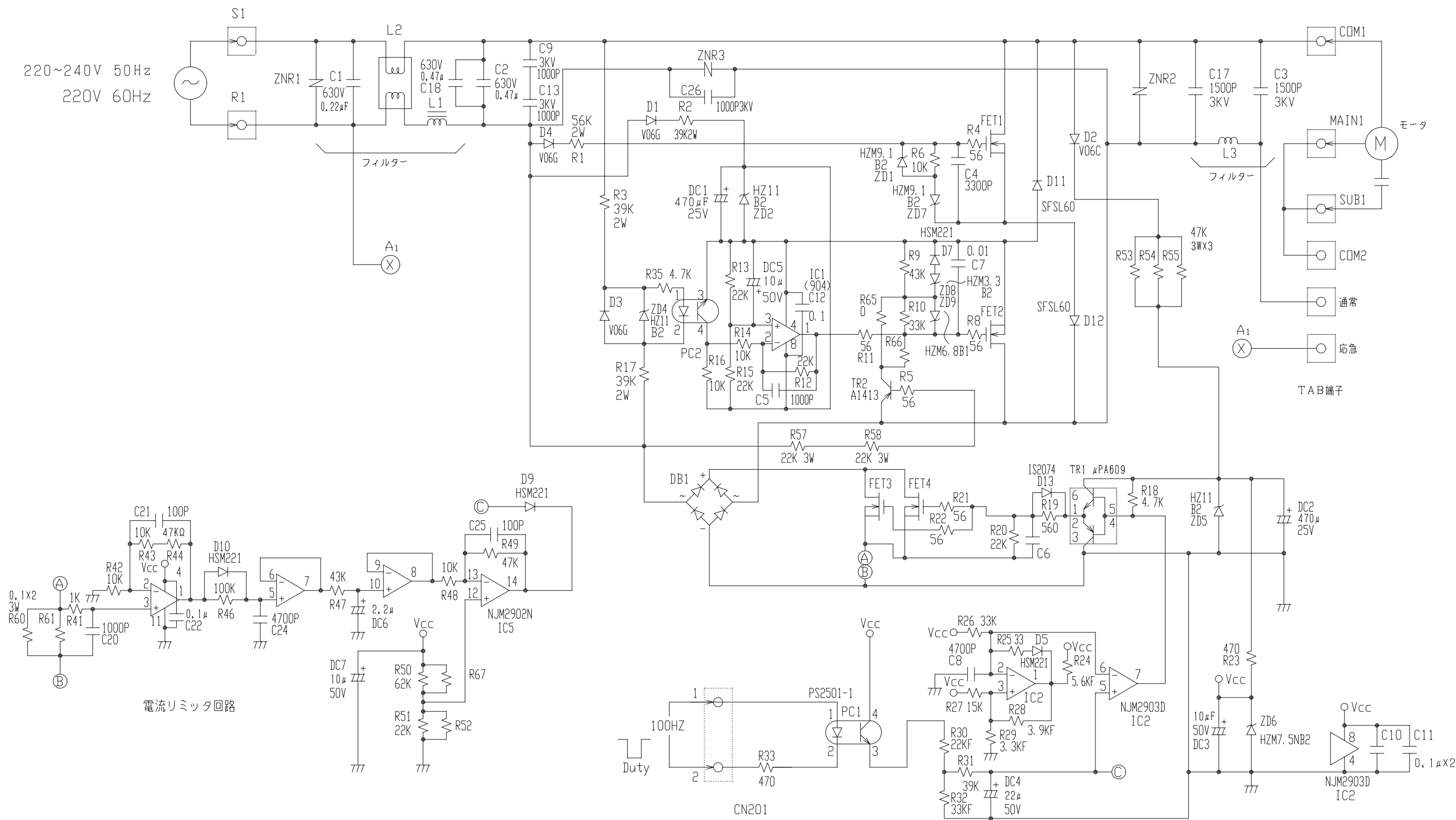

■ Inverter Board: PCB3

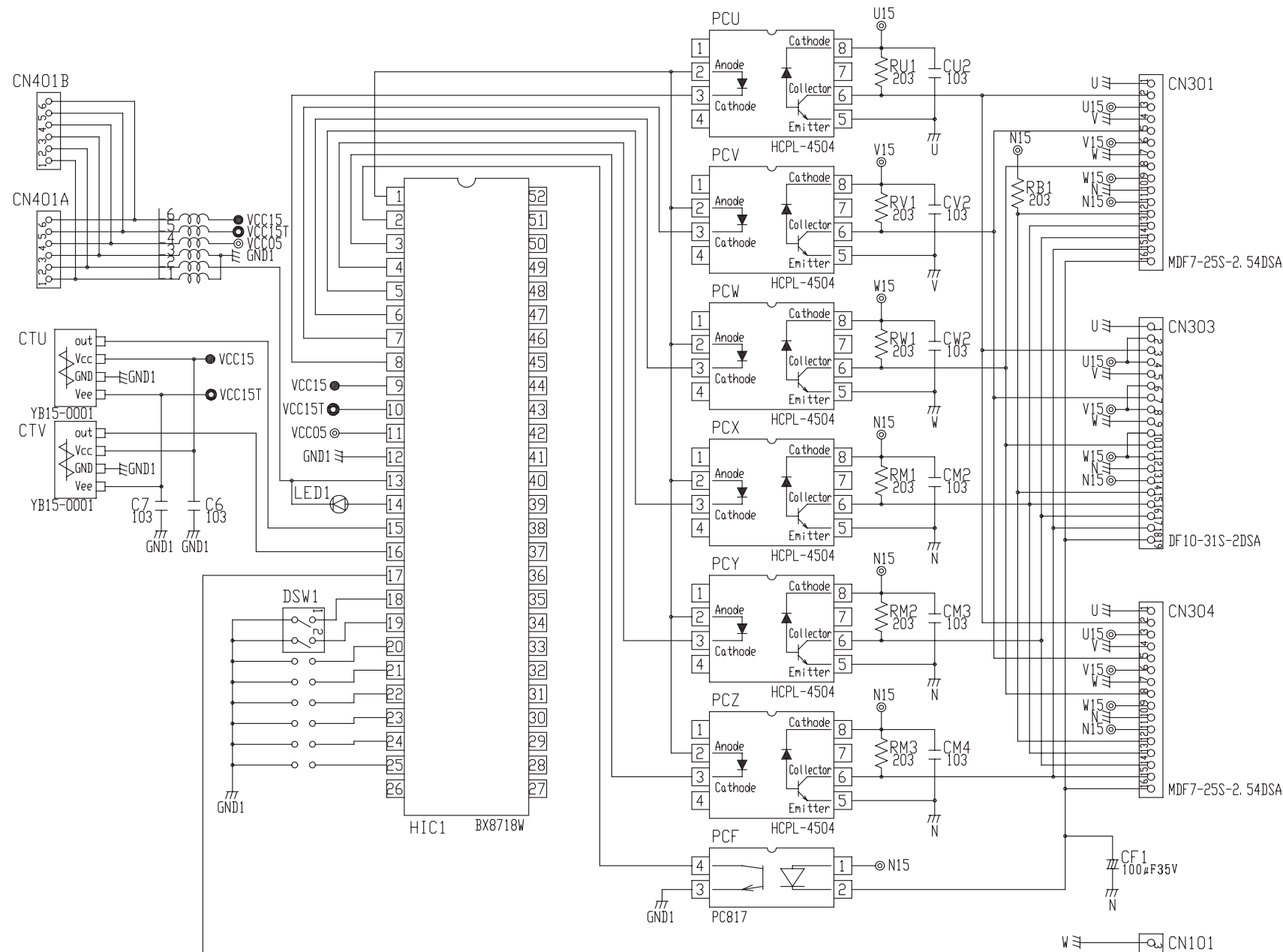

■ Snubber Board: PCB5

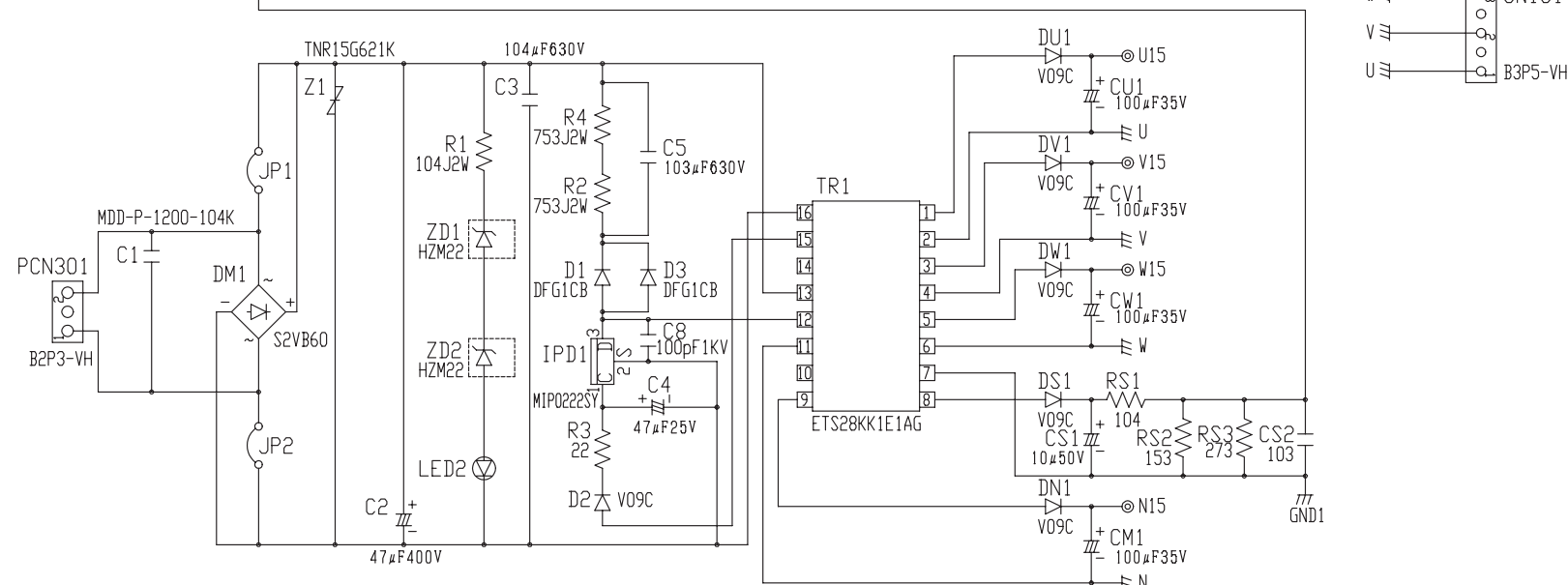
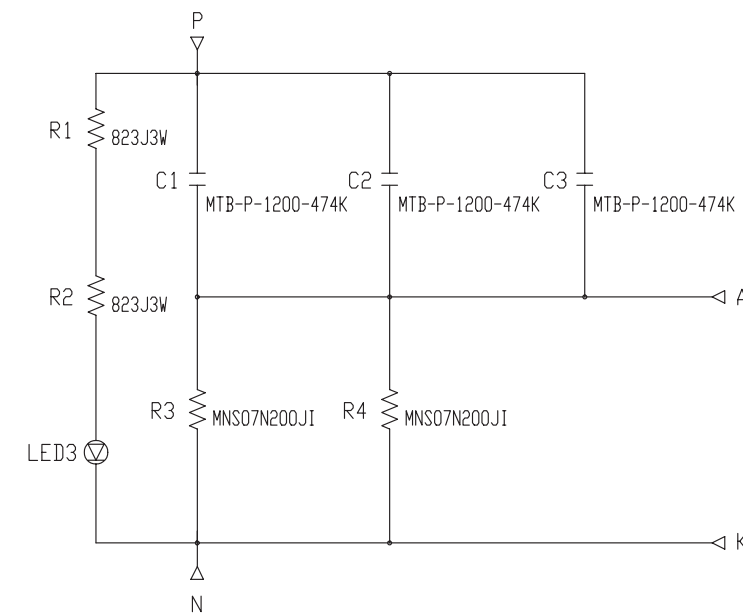

3.9. CIRCUIT DIAGRAM FOR PRINTED CIRCUIT BOARD OF INDOOR UNIT

■ Control Board: PCB of Indoor unit (Except for RPK Model)

■ Fan Control Relay Board: PCB of indoor Unit

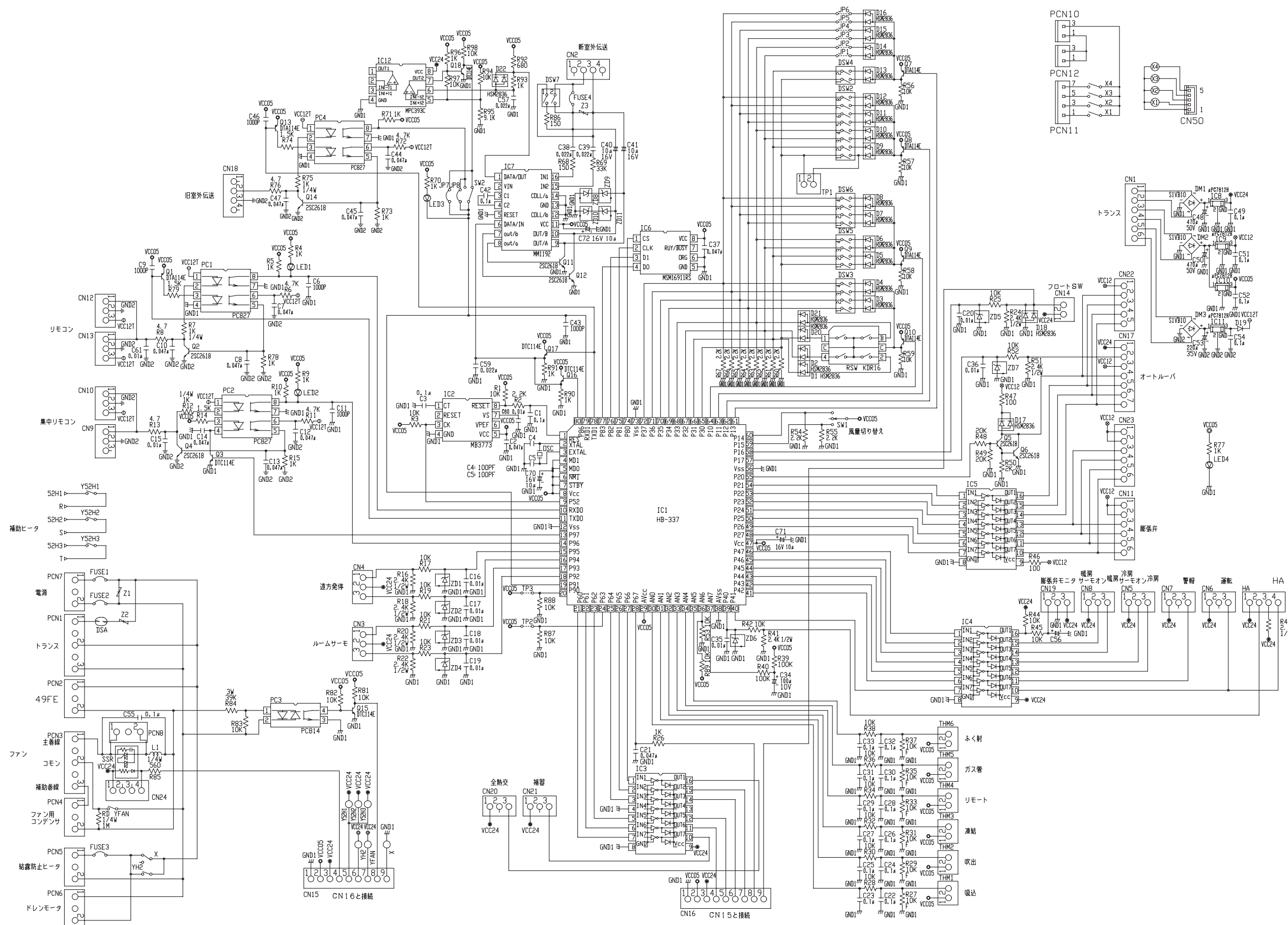

Control Board: PCB of Indoor Unit (Only for RPK Model)

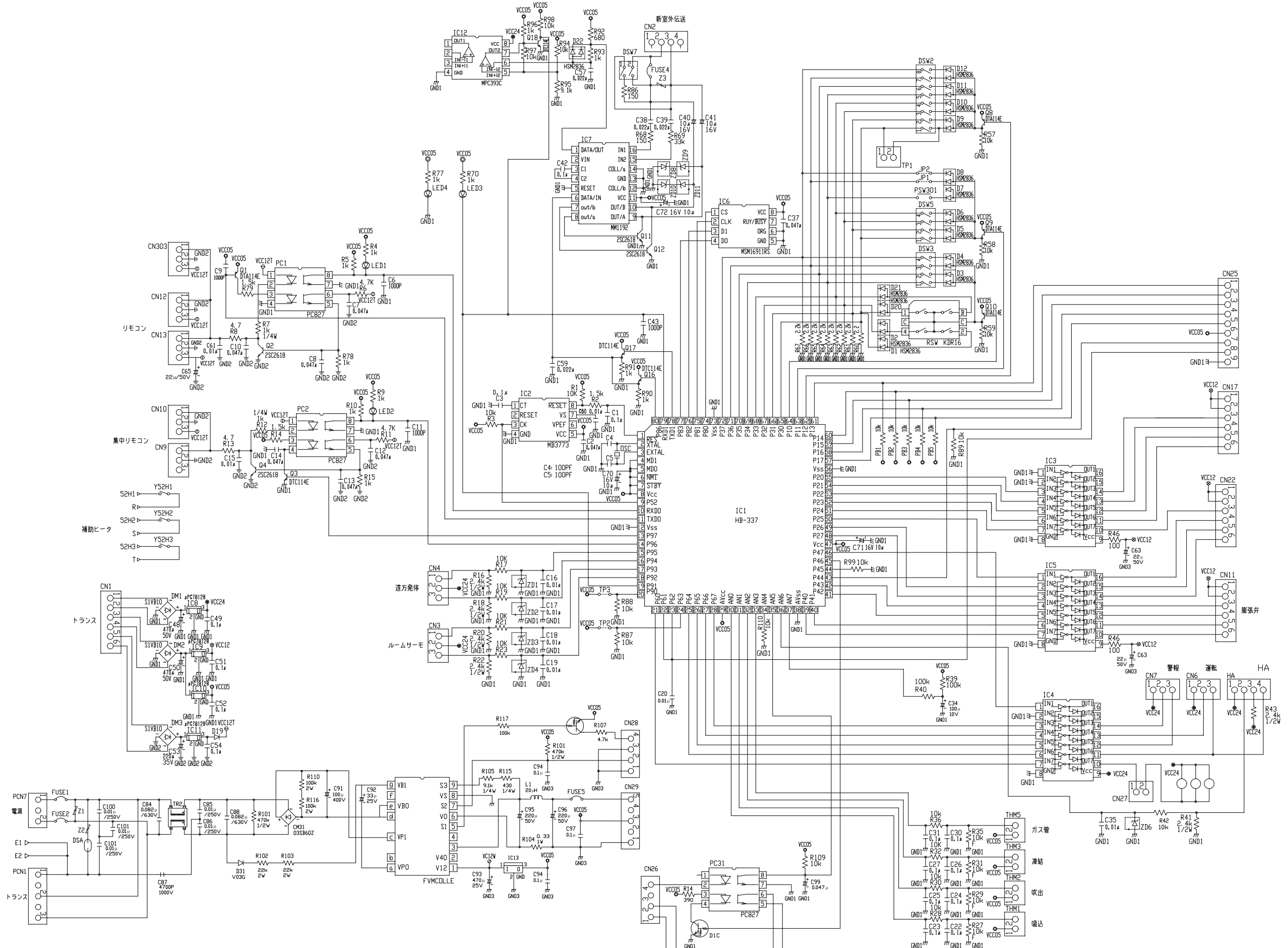

3.10.CIRCUIT DIAGRAM FOR PRINTED CIRCUIT BOARD OF REMOTE CONTROL SWITCH

■ PC-2H2

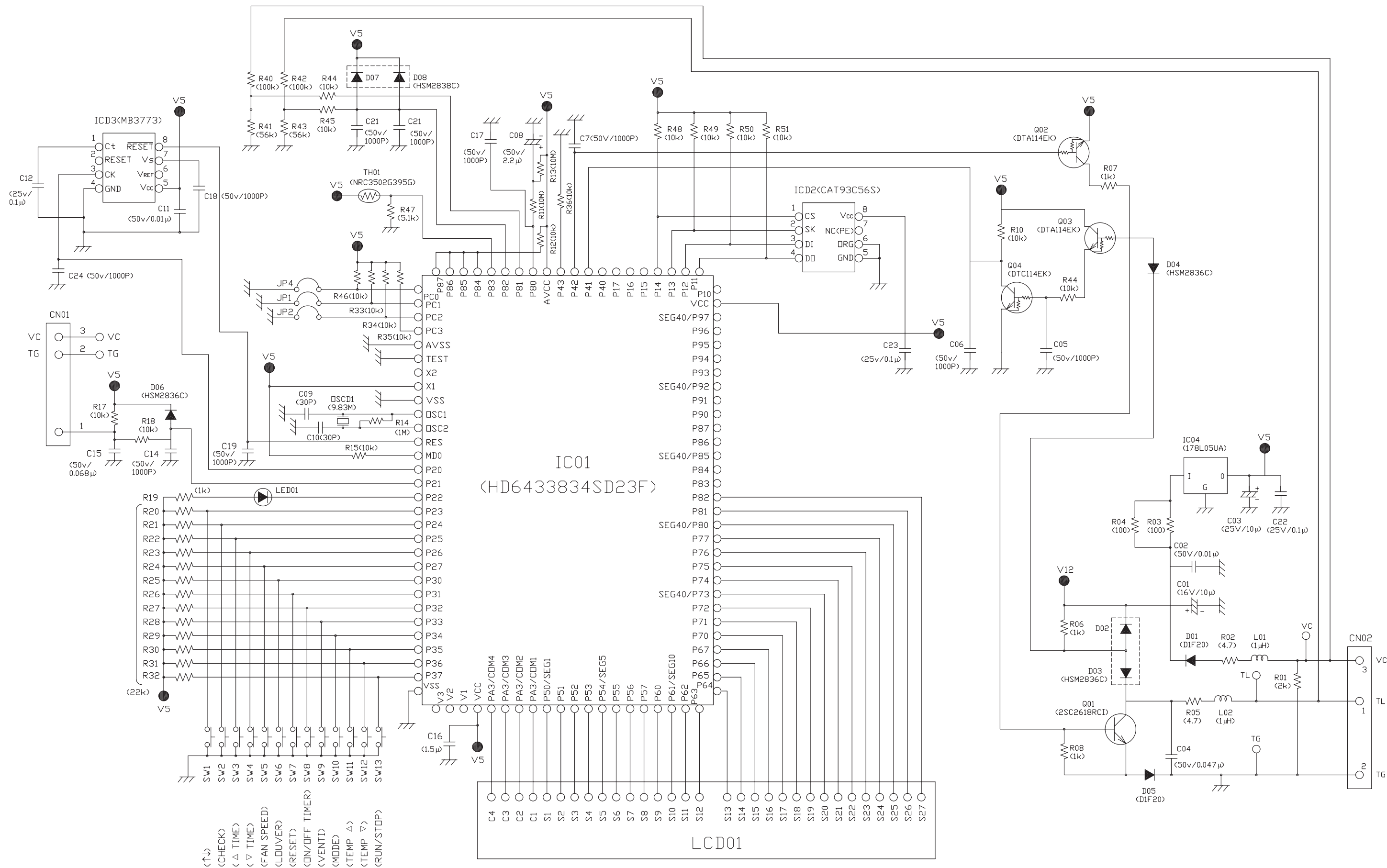

■ PC-5H

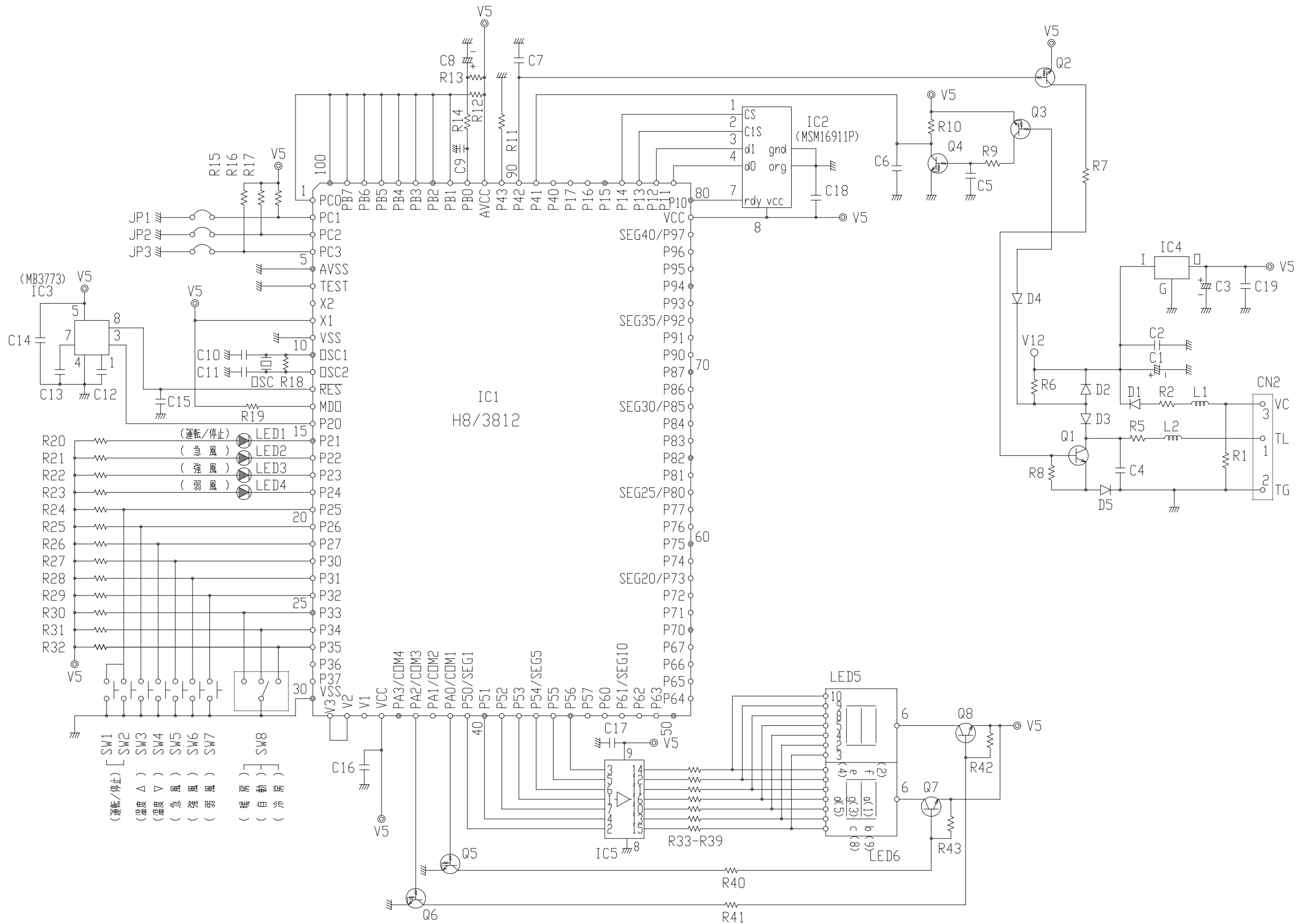

3.11. CIRCUIT DIAGRAM FOR PRINTED CIRCUIT BOARD OF RECEIVER

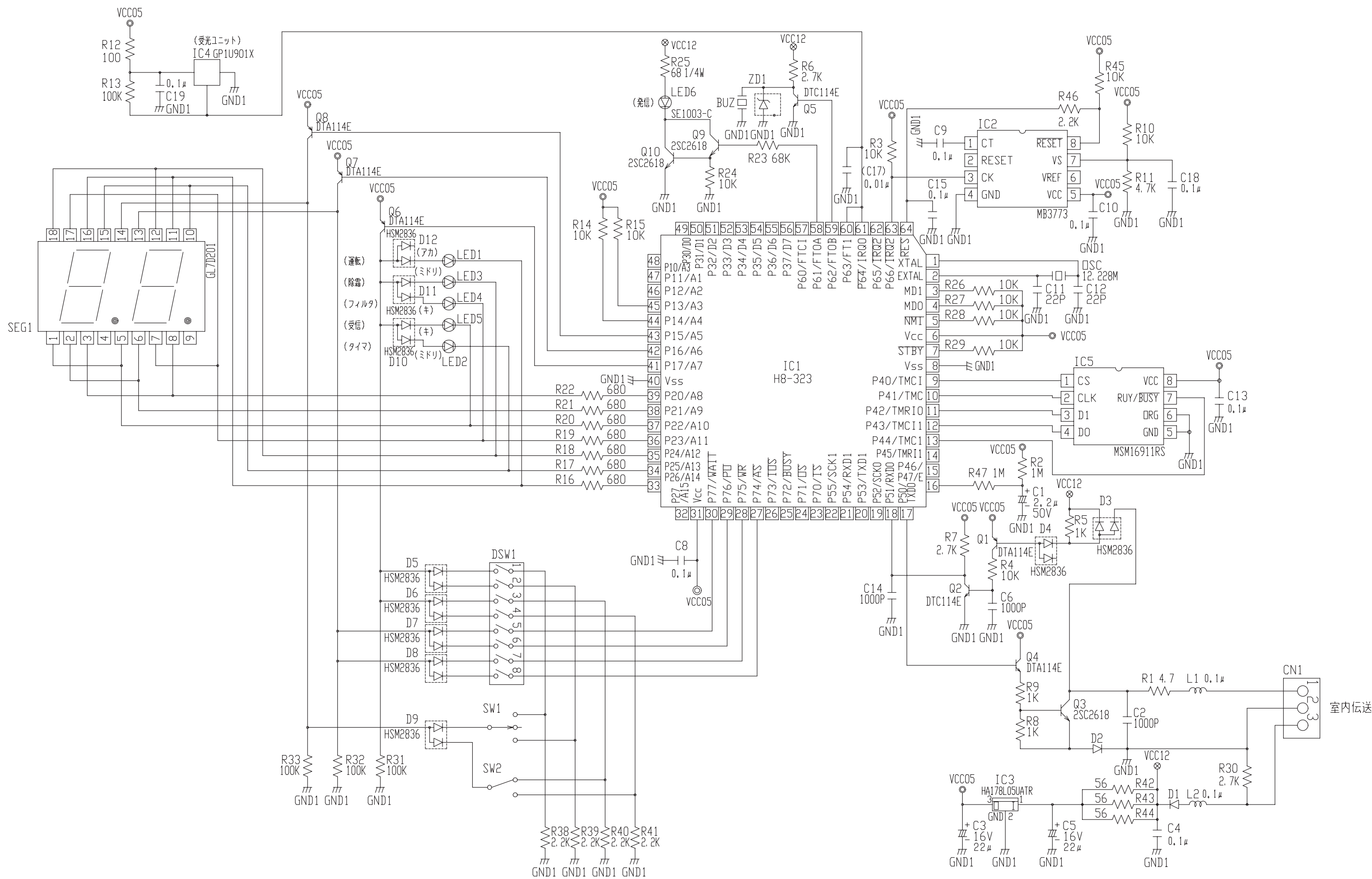

4. OPTIONAL FUNCTION

4.1. INDOOR UNIT

4.1.1. REMOTE CONTROL ON/OFF FUNCTION

This function provides a control to stop and start the system automatically from a remote place. Three methods are available by using each signal from a building management system.

■ Remote Control 1 (Level Signal Input)

This is an ON/OFF function from a remote place by using level signal (or ON/OFF). The basic wiring, time chart are shown below.

- Wiring Diagram Example of Remote Control 1:

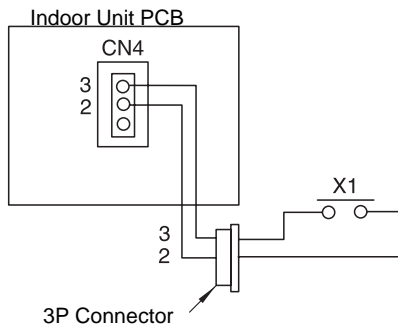

NOTE:

When the unit is started by the remote ON/OFF switch, the fan speed is subject to the mode memorized in the remote control switch.

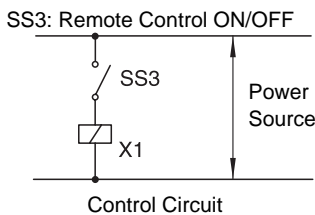

- Time Chart:

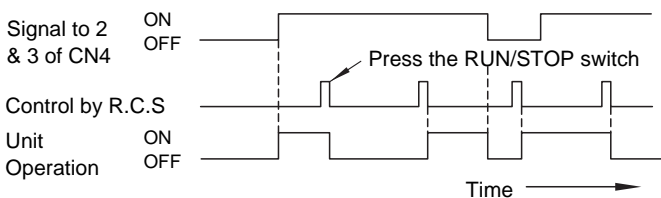

NOTE:

Operation priority is given to the remote ON/OFF signal or remote control switch signal which is given last.

NOTES:

Picking up signal within 10 seconds after power supply is turned ON is not available due to initializing of components.

■ Remote Control 2 (Pulse Signal Input)

This is an ON/OFF function from a remote place by using pulse signal. The basic wiring and time chart are shown below.

CAUTION:

Turn OFF the power source before setting the dip switch.

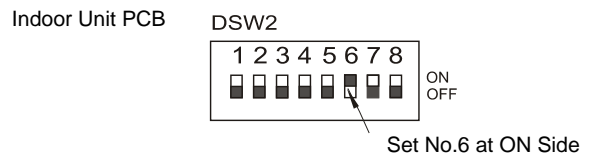

- Wiring Diagram Example of Remote Control 2:

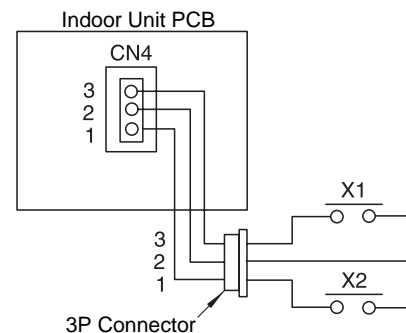

NOTE:

When the unit is started by the remote ON/OFF switch, the fan speed is subject to the mode memorized in the remote control switch. The pulse width shall be wider than 200ms.

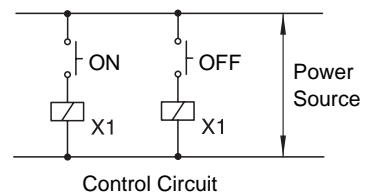

- Time Chart:

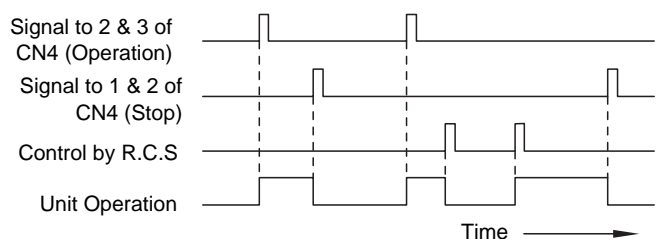

NOTE:

Operation priority is given to the remote ON/OFF signal or remote control switch signal which is given last.

NOTES:

This function is available when "4.1.3 Power Supply ON/OFF 2 (after Power Failure)" is applied. Picking up signal within 10 seconds after power supply is turned ON is not available due to initializing of components.

■ **Remote Control 3 (Pulse Signal Input)**

By using the signal from a building management system, the air conditioners can be stopped. If a signal is input during stoppage of air conditioner, the air conditioner remains unchanged. The basic wiring and time chart are shown below.

CAUTION:

Turn OFF the power source before setting the dip switch.

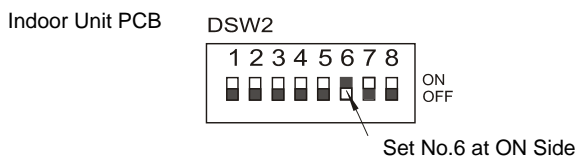

■ **Wiring Diagram Example of Remote Control 3:**

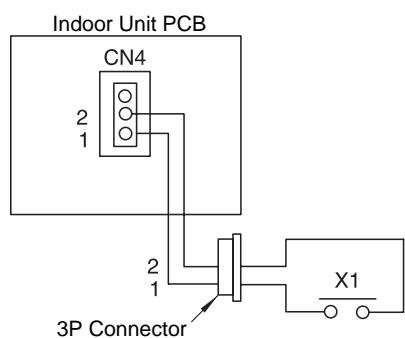

NOTE:

The pulse width shall be wider than 200ms.

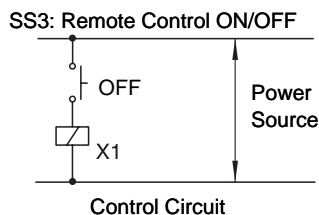

■ **Time Chart:**

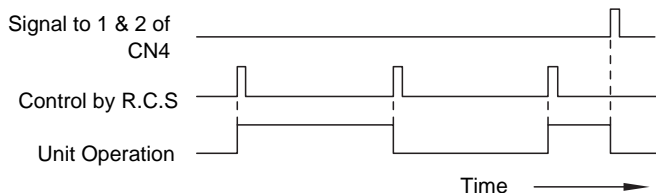

NOTES:

This function is available when "4.1.3 Power Supply ON/OFF 2 (after Power Failure)" is applied. Picking up signal within 10 seconds after power supply is turned ON is not available due to initializing of components.

■ **Cancellation of Commands from Remote Control Switch after Forced Stoppage (Level Signal Input)**

By using the signal from a building management system, the air conditioners can be stopped and the commands from the remote control switch are canceled. The basic wiring and time chart are shown below. The required parts are shown in Table 4. 1

■ **Wiring Diagram Example:**

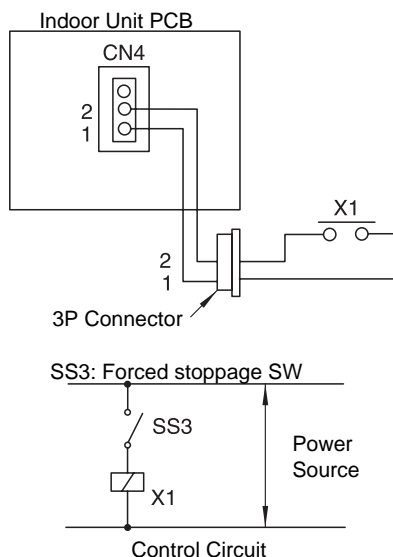
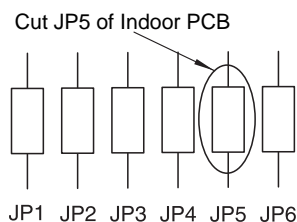

■ **Time Chart:**

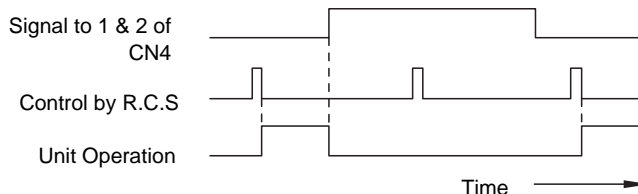

NOTE:

Picking up signal within 10 seconds after power supply is turned ON is not available due to initializing of components.

Table 4. 1 Specifications on Required Components for (1)~(4) Functions:

Component		Manufacturer or Specifications	Remarks
Auxiliary Relay (X1, X2)		OMRON Mini Power Relay Model: MY1F or Equivalent	Voltage 220V or 240V
Changeover Switch (SS2, SS3)		Manual Type	
3P Connector Cord		Optional Part PCC-1 (Able to Connect JST Connector XHP -3)	Five Cords with Connectors as one set
Cord (Inside of Unit)	Low Voltage	0.3mm ²	less than 24V
	220V/240V Class	0.5~0.75mm ²	
Cord (Outside of Unit)	Low Voltage	0.3~0.75mm ²	less than 24V
	220V/240V Class	2mm ²	

NOTE:

Make the wires CN4 as short as possible. Do not install the wires along the 200-400V power line. Separately install them at a distance of more than 30cm. (Intersecting as applicable.) If the wires are installed along the power line, put the wires in a metal tube and connect a wire to an end for grounding. The maximum wiring length is 70m. In the case that this function is used, it is recommended that safety devices such as electric leakage breaker or smoke detector, etc. be used.

4.1.2. POWER SUPPLY ON/OFF 1 (AUTOMATIC OPERATION WHEN POWER SUPPLY ON)

Set the dip switch on the PCB for the indoor unit as shown in the figure below to start and stop the system automatically according to the power supply ON/OFF. When this function is utilized in the condition that there is no person to operate the unit, make the system with monitoring for disaster prevention.

CAUTION:

Turn OFF the power source before setting the dip switch.

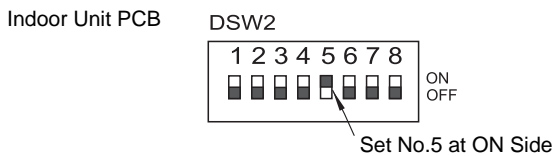

NOTE:

The unit is started and stopped according to the power supply ON/OFF due to the power failure. When the power failure is occurred during stoppage by the remote control switch operation, the unit is started again automatically after the power supply is recovered.

4.1.3. POWER SUPPLY ON/OFF 2 (RESTARTING FUNCTION AFTER POWER FAILURE)

Set the dip switch on the PCB for the indoor unit as shown in the figure below to restart the system automatically even if power failure continues for more than 2 seconds. The standard setting provides automatic restarting in less than 2 seconds after a power failure. The compressor starts in 2 seconds after a 3 minute time guard after power failure.

CAUTION:

Turn OFF the power source before setting the dip switch.

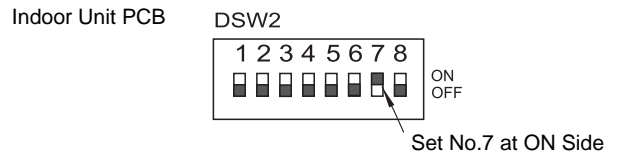

NOTE:

The system does not start if the system is stopped before power failure.

4.1.4. CONTROL BY FIELD-SUPPLIED ROOM THERMOSTAT

In the case that a field-supplied room thermostat instead of the inlet thermistor of the indoor unit is used, connect wires as shown below. The required parts are shown in Table 4. 2

- Field-Supplied Room Thermostat:

CAUTION:

Turn OFF the power source before setting the dip switch.

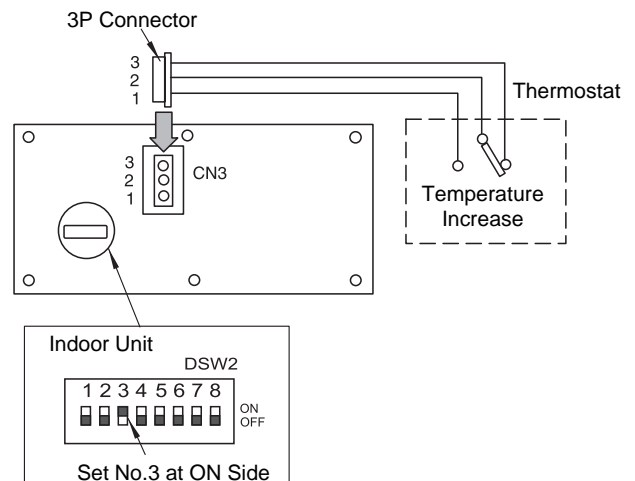

Operation During:**Cooling Operation:**

Compressor is ON by closing terminals 2 and 3 at CN3
 Compressor is OFF by opening terminals 2 and 3 at CN3

Heating Operation:

Compressor is ON by closing terminals 1 and 2 at CN3
 Compressor is OFF by opening terminals 1 and 2 at CN3

Table 4. 2 Specifications on Required Components:

Component	Manufacturer or Specifications
Thermostat	Equivalent of YAMATAKE R7031P005, R7031Q005

NOTES:

When a field-supplied room thermostat is used, select the specified thermostat as below:

Contactor Load: DC24V 50 to 6 mA

Differential: more than 1.5 degree

Do not use a thermostat utilizing mercury.

This function can be used together with 4.1.1 Remote Control ON/OFF Function

4.1.5. OPERATION CONTROL BY REMOTE TEMPERATURE SENSOR

By using an optional remote temperature sensor, the followings are available.

1. The unit is controlled by the average temperature of the inlet air thermistor and remote temperature sensor.
2. In the case that the discharge air temperature exceeds 60 °C, the fan speed increases from "Medium" to "High" or "Low" to "Medium".

- Remote Temperature Sensor : THM-R2:

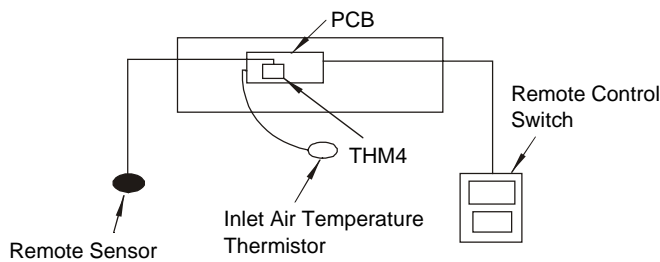
**NOTES:**

The remote temperature sensor can not be used together with the remote control thermistor. (Refer to the item 4.3.5 (10).)

During the heating operation, "Heating Temperature Calibration" is automatically cancelled. (Refer to the item 4.3.5 (1).)

4.1.6. COOLING OR HEATING OPERATION MODE SETTING CHANGE BY EXTERNAL INPUT (Level Signal Input)

By utilizing this function, the cooling or heating operation mode can be changed by giving a contact signal from the outside to the unit. The operation mode is followed by the field-supplied switch or the remote control switch, which is used last.

- Wiring Diagram Example of Remote Control 2:

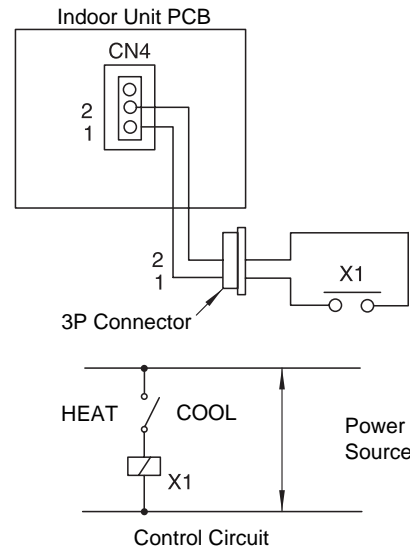

- Time Chart:

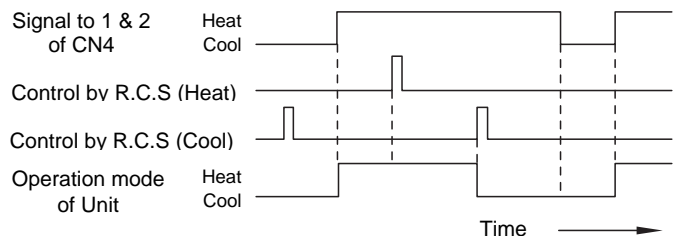
**NOTE:**

This function can not be used together with the following functions; "Remote Control 2", "Remote Control 3" and "Cancellation of Commands from Remote Control Switch after Forced Stoppage".

4.1.7. PICKING UP OPERATION SIGNAL

■ Picking Up Operation Signal

This function is utilized to pick up the operation signal. By this function, operation signal at a remote place can be checked, or operation at the fresh air intake fan motor can be interlocked. Connect wires as shown below. The required parts are indicated Table 4. 3. Please note that the contact of the auxiliary relay "RYa" is closed when this operation signal is given.

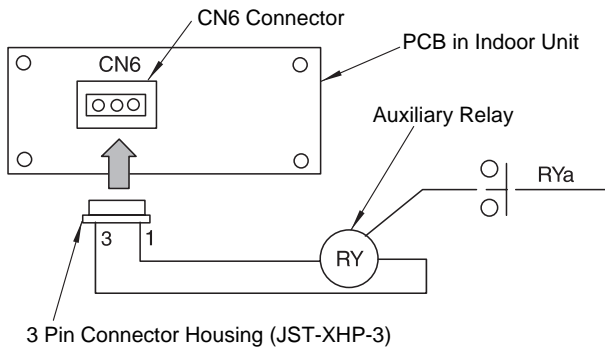
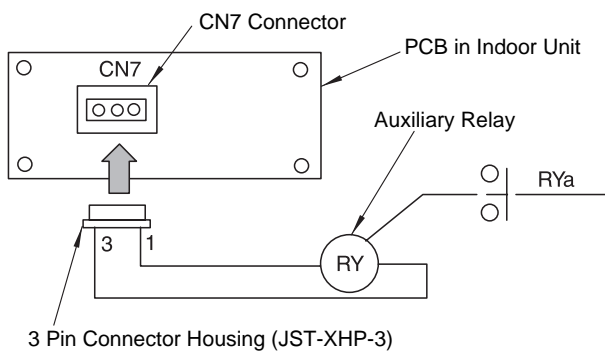

Table 4. 3 Required Parts for Modification

Parts Name	Specifications or Model
Auxiliary Relay	OMRON made High Power Relay Model LY2F DC24V
Connector Cable	PCC-1 (3P Connector Cable)

■ Picking Up Alarm Signal

This signal is utilized to pick-up activation of safety devices. However, this function is not available under abnormal transmission conditions of the remote control switch. Connect the wires as shown below. The required parts are indicated in Table 4. 3. Please note that the contact of auxiliary relay, RYa is closed when one of the safety devices is activated.



■ Picking Up Heating Operation Signal (RPK-FSGM is not available)

This function is utilized to pick up the heating operation signal. The contact of RYa is closed when heating operation signal is ON despite "Thermo-ON" or "Thermo-OFF". Connect the wires as shown below.

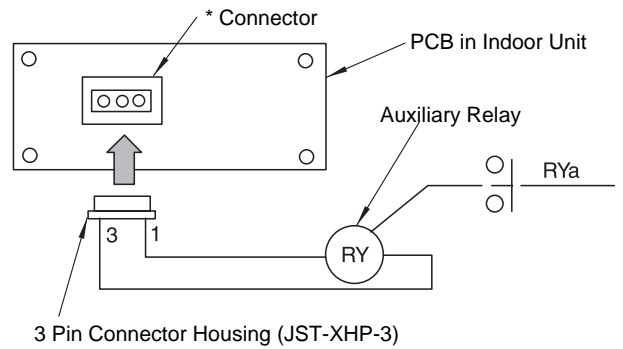

* Connector No.	Indoor Unit
CN8	RCD - FSG(E), RPF(I) - FSG(E)
CN21	RCI-FSGE, RPI-FSG(E), RPC-FSGE

■ Picking Up "Thermo-ON" Signal during Heating Operation (Only for RCD-FSG(E) and RPF(I)-FSG(E) models)

This function is utilized to pick up the heating "Thermo-ON" signal of compressor running to control a circulator or a humidifier. Connect wires as shown below. The required parts are indicated in Table 4. 3. The contact of RYa is closed when "THERMOSTAT" is ON during heating operation mode.

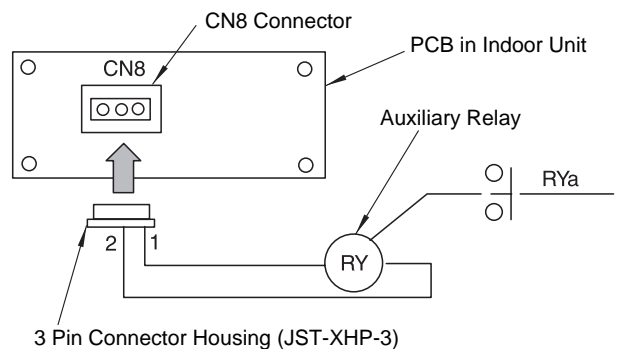

NOTE:

"Thermo-ON" indicates that one of the micro-computer control function "THERMOSTAT" is ON as a thermostat.

■ **Picking Up Cooling Operation Signal (RPK-FSGM is not available)**

This function is utilized to pick up the cooling operation signal. The contact of RYa is closed when cooling operation signal is ON despite "Thermo-ON" or "Thermo-OFF". Connect the wires as shown below. The required main parts are indicated in Table 4. 3

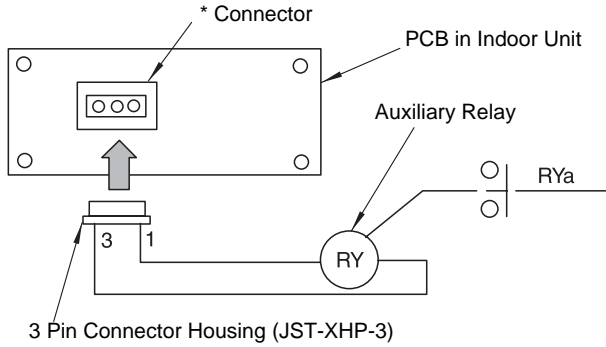

* Connector No.	Indoor Unit
CN5	RCD - FSG(E), RPF(I) - FSG(E)
CN20	RCI-FSGE, RPI-FSG(E), RPC-FSGE

■ **Picking Up "Thermo-ON" Signal during Cooling Operation (Only for RCD-FSG(E) and RPF(I)-FSG(E) models)**

This function is utilized to pick up the cooling "Thermo-ON" signal of compressor running. Connect wires as shown below. The required parts are indicated in Table 4. 3. The contact of RYa is closed when "THERMOSTAT" is ON during cooling operation mode.

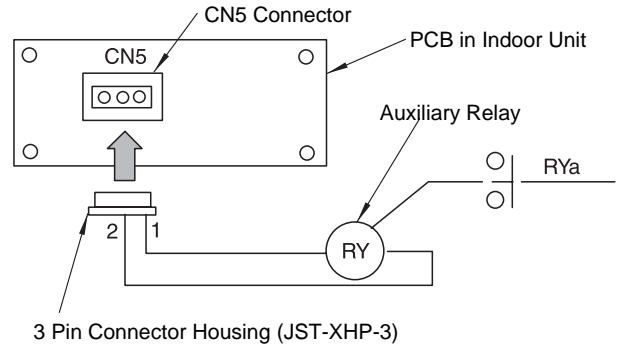

NOTE:

"Thermo-ON" indicates that one of the micro-computer control function "THERMOSTAT" is ON as a thermostat.

4.2. OUTDOOR UNIT

On the outdoor unit printed circuit board, there are three input terminals to receive external signals and two output terminals to send signals outwards. These signals are available by setting as shown below.

Function No.	Input	Output
1	Fixing Heating Mode	Operation Signal
2	Fixing Cooling Mode	Alarm Signal
3	Demand	Compressor ON Signal
4	Snow Sensor	Defrosting Signal
5	Enforced Stoppage	--

Each input terminal and output terminal are set before shipment as shown below.

Input/Output Name	Connector Pin No.	Setting Function (No.)
Input 1	CN17 (1-2)	Fixed Heating Mode (1)
Input 2	CN17 (2-3)	Fixed Cooling Mode (2)
Input 3	CN18 (1-2)	Demand (3)
Output 1	CN16 (1-2)	Operation (1)
Output 2	CN16 (1-3)	Alarm (2)

In the case that the above setting change is required at site, perform the following procedures.

1. Set No. 1 pin on the dip-switch, DSW8 on the outdoor printed circuit board at the "ON" side while the main power to the outdoor unit is being supplied. By setting, function selection mode is available and the following appears on the 7-segment display.

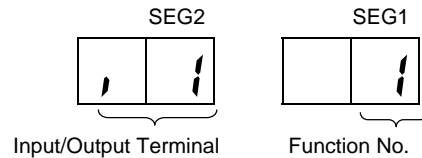

This display indicates that the function No. 1 (Fixed Heating Mode) is set at input 1.

- By pressing the push-switches PSW2 and PSW3, input/output terminal name is changed. The following shows the display changes when PSW2 and PSW3 are pushed.

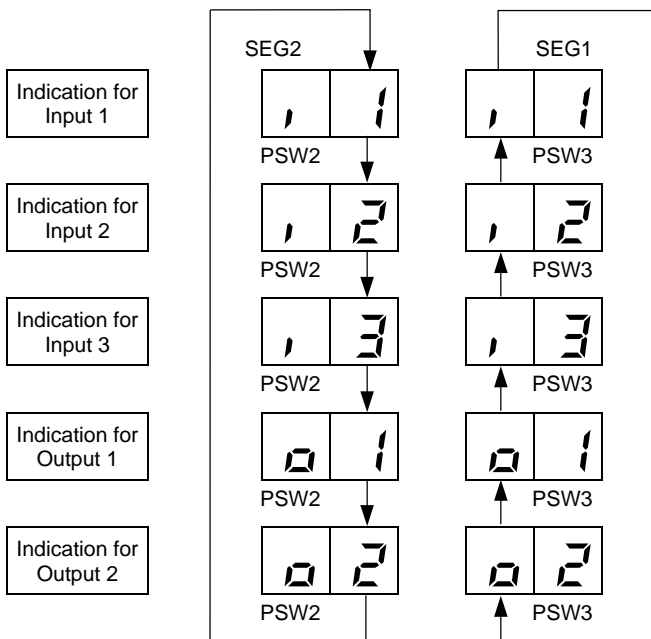

- After the input/output terminal name is selected, select your required function No. by pushing PSW2 or PSW3 while PSW1 is being pushed.

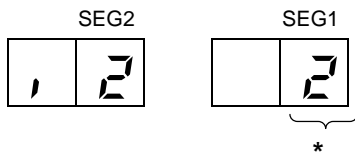

*) This number is increased by 1 by pushing PSW2 while PSW1 is being pushed. This number is decreased by 1 by pushing PSW3 while PSW1 is being pushed.

- After selecting the function No., return No. 1 pin at the "OFF" side on the DSW8. The selected contents are memorized in the outdoor unit printed circuit board. and the function selection mode is stopped. The memorized data is maintained even power source lines are disconnected. The connecting details of each function are described below, and the required parts are also indicated below.

4.2.1. DEMAND

In the case that the demand input terminals on the outdoor unit printed circuit board are short-circuited, compressor(s) is stopped. (In this case, the indoor unit(s) is put under thermo-OFF condition.) The stoppage code No. "10" is given. By disconnecting the demand switch contact, restarting is available. The following indicates an example for Demand at input 3 (between 1 and 2 pins of CN18).

- Wiring Diagram Example of Demand Control

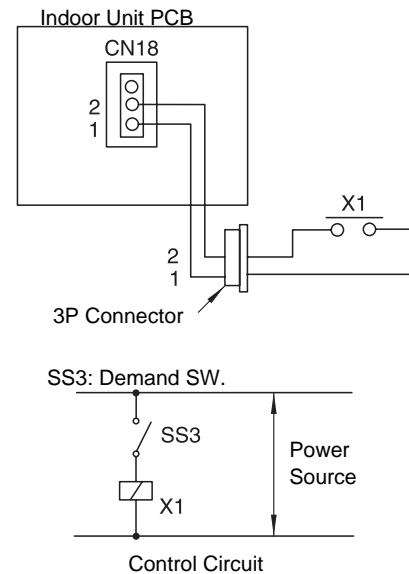

4.2.2. FORCED STOPPAGE

The compressor is stopped and the indoor fan motor is stopped when the forced stoppage input terminals(CN18 #1~ #2) on the outdoor unit PCB is short-circuited during running. However, the remote control switch display remains at the same mode and the stoppage cause code "d1" will be No."10". In this case, if the input terminals are opened, operation is resumed.

- Wiring Diagram Example of Forced Stoppage:

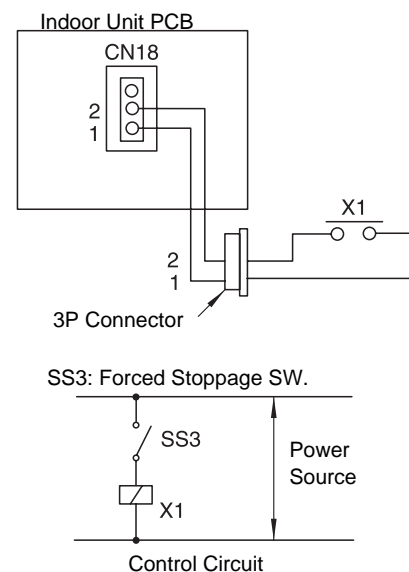

4.2.3. FIXING OPERATION MODE

In the case that the fixing input terminals of the operation mode on the outdoor PCB are short-circuited, the operation mode can be fixed at the cooling or heating mode.

Short-circuit between Terminals 1 and 2 of CN17: Fixed Heating Mode

Short-circuit between Terminals 2 and 3 of CN17: Fixed Cooling Mode

This fixed mode will be shared in the RCS. During this fixed heating (or cooling) mode, no cooling (or heating) operation is available. If cooling (or heating) mode is selected, the indoor units under the cooling or dry operation (or heating operation) will be changed to the Thermo-OFF condition during this mode, and an alarm code of "20" appears.

The stoppage cause code "d1" will be "20"

Wiring Diagram Example of Fixing Operation Mode:

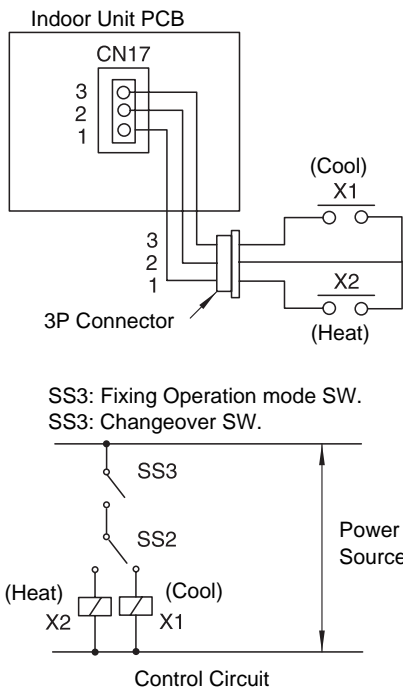

4.2.4. SNOW SENSOR

In the case that the input terminals of the snow sensor are short-circuited during compressor stoppage, all the outdoor fan motors are operated at the full speed. However, if the compressor is called for compressor operation, the fan operation is changed to the normal operation. If the input terminal is opened, the fan(s) is stopped. This function protects the outdoor units from a condition covered with snow.

Wiring Diagram Example of Snow Sensor

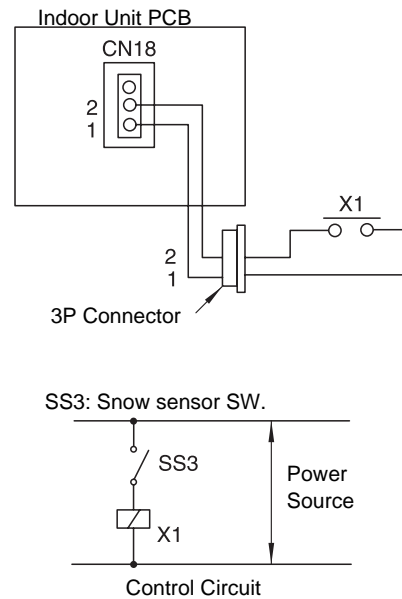

Table 4. 4 Specifications of Required Main Parts

Parts	Specifications	Remarks	
Auxiliary Relay (X1, X2)	Mini-Power Relay, MY1F (or 2F) made by OMRON	220/240V	
Changeover Switch (SS2, SS3)	Manual Switch	220/240V	
3 Pin Connector Cord	PCC-1A (connected to JST connector, XARP -3)	five cords with connectors as one set	
Cord (inside of Unit)	Low Volt.	0.3mm ²	lower than 24V
	220/240V	0.5~0.75mm ²	
Cord. (outside of Unit)	Low Volt	0.5~0.75mm ²	lower than 24V
	220/240V	2mm ²	

NOTES:

Make the wire to the terminals as short as possible. Do not run the wires along high voltage cable. (crossing is applicable.) If necessary to run wires along high voltage cable, insert the low voltage cable(s) into metal tube and ground it at one end. If sealed wires are used at the low voltage wire side, ground it at one end of shield wires. The maximum length should be 70m.

4.2.5. DEFROSTING CONDITION CHANGEOVER

By changing the position of No.5 on dip switch, DSW5, defrosting operation conditions can be changed.

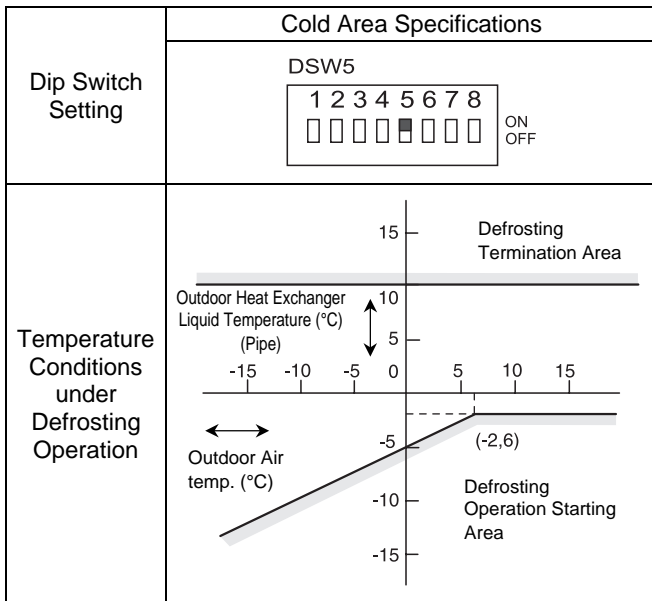
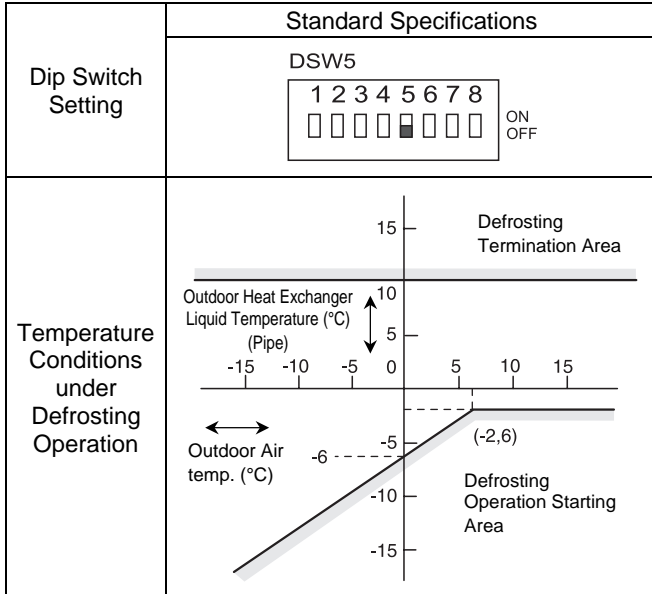

No. 5 of DSW5 is set at OFF before shipment. Turn OFF the main switch and set the dip switch.

4.2.6. INDOOR FAN CONTROL DURING THERMO-OFF AT HEATING

By setting the dip switch as shown below, the indoor fan operates for 2 min. and stop for 6 min. as a cycle when the activation conditions are satisfied.

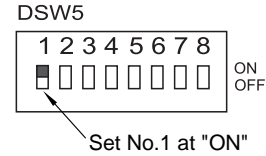

No. 1 of DSW5 is set at OFF before shipment. Turn OFF the main switch and set the dip switch.

Operation Conditions	Operation
Under compressor running except defrosting operation.	When the indoor unit is at thermo-OFF during the heating operation, the indoor fan operates for 2 minutes and stops for 6 minutes within cycles.

NOTE:
When the indoor fan is stopped by another control, it is not available to operate indoor fans.

4.2.7. ALL SEASON HEATING OPERATION

By setting the dip switch, the heating operation through the year is available. The heating operation is continued under a high outdoor temperature.

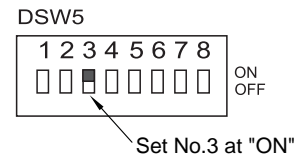

No. 3 of DSW5 is set at OFF before shipment. Turn OFF the main switch and set the dip switch.

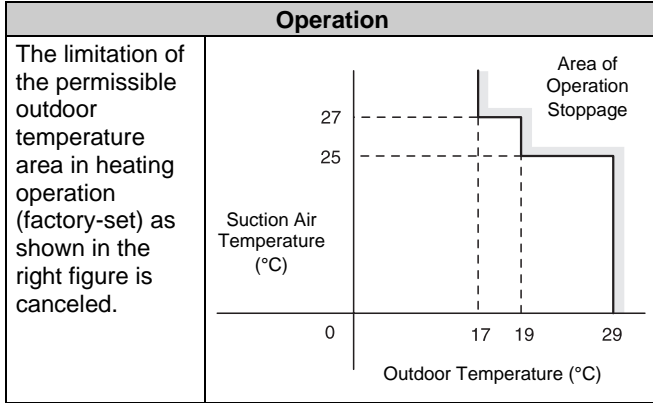

NOTE:

The operation may be OFF due to high outdoor temperature protection control, since protection control is not cancelled.

4.2.8. ALL SEASON COOLING OPERATION

By setting the dip switch, the cooling operation through the year is available. The cooling operation is continued a low temperature.

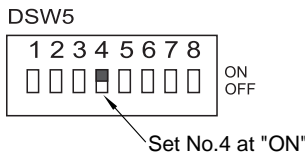

No. 4 of DSW5 is set at OFF before shipment. Turn OFF the main switch and set the dip switch.

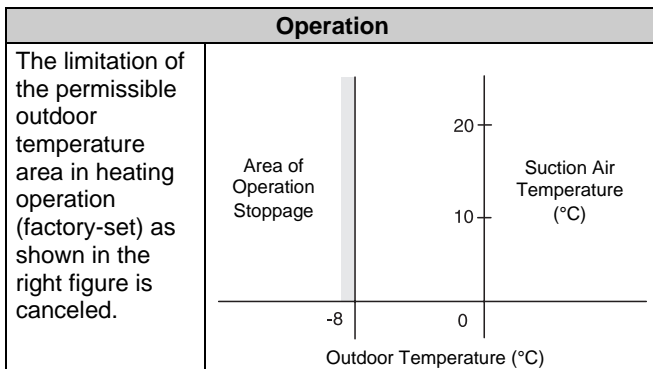

NOTE:

The operation may be OFF due to high outdoor temperature protection control, since protection control is not cancelled.

4.2.9. NIGHT SHIFT (LOW SOUND) OPERATION

By Changing No.2 of the dip switch, DSW5, the night shift (low sound) operation can be set. In case of the night shift operation, the cooling capacity is decreased down to 60%. The night shift operation shall be applied only in case that the cooling capacity has the margin to be allowed for the capacity decrease and the low sound operation is required especially in the nighttime

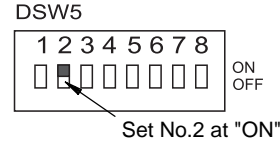

Outdoor Fan

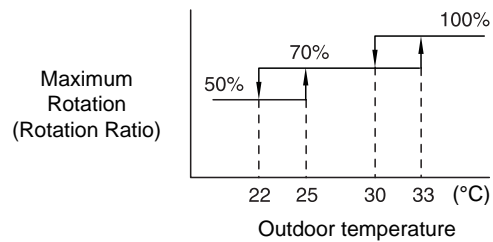

NOTE:

The maximum rotation is always 100% (rotation ratio) for the standard unit. (no limitation of the outdoor temperature)

Frequency Range

	Outdoor Unit Capacity (HP)	Minimum Frequency	Maximum Frequency	Conditions
When Night Shift Is Not Set	5	30Hz	95 Hz	Except for the conditions below
	8		165 Hz	
	10		177 Hz	
	16		255 Hz	
	20		325 Hz	
When Night Shift Is Set	5	30Hz	50 Hz	1. Night Shift Operation 2. Cooling Operation 3. Outdoor Fan: Below 70%
	8		100 Hz	
	10		114 Hz	
	16		140 Hz	
	20		176 Hz	

Converter Frequency of Constant Speed Compressor

Outdoor Unit Capacity (HP)	Power Supply Frequency	
	50 Hz	60 Hz
8	50 Hz	60 Hz
10	62 Hz	74 Hz
16	70×2 Hz	84×2 Hz
20	70×3 Hz	84×3 Hz

NOTE:

The maximum Frequency for the 8~20 HP outdoor unit is indicated as; Inverter Frequency + Converter Frequency of Constant Speed Compressor.

4.2.10. PICKING UP SIGNALS FROM OUTDOOR UNIT PRINTED CIRCUIT BOARD

The parts applied to picking up operation signals are shown in Table 4. 5

Table 4. 5 Main Required Part

Part Name	Manufacturer etc.
Auxiliary Relay	OMRON High Power Relay Model: LY2F DC12V

■ Picking Up Alarm Signal

With this procedure the Outdoor unit alarm signals can be picked up. The method is explained in the figure below. The required part is indicated in Table 4. 5. Connecting relay contactors (RYa) are closed at the time of alarm. (When either one of the units issues an alarm, an alarm signal is indicated.)

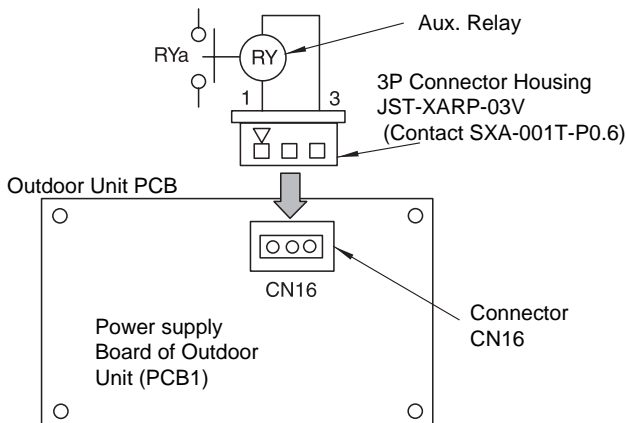

■ Picking Up Operation Signal

With this procedure the operation signal of cooling or heating can be picked up. The method for picking up the signal is explained in the figure below. The required part is the same as in Table 4.5. Connecting relay contactors RYa are closed at the time of cooling or heating. These signals can be applied to the operation of circulators and humidifiers.

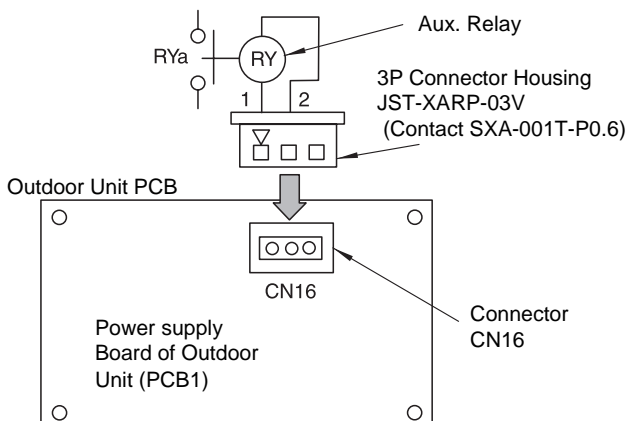

■ Picking Up Compressor ON Signal

With this procedure the compressor signal can be picked up. The method is explained in the figure below. The required part is indicated in Table 4. 5. Connecting relay contactors (RYa) are closed at the time of compressor running. This signal can be applied to the check of signals at the time of remote controlling and to the fan interlock of outdoor fresh air.

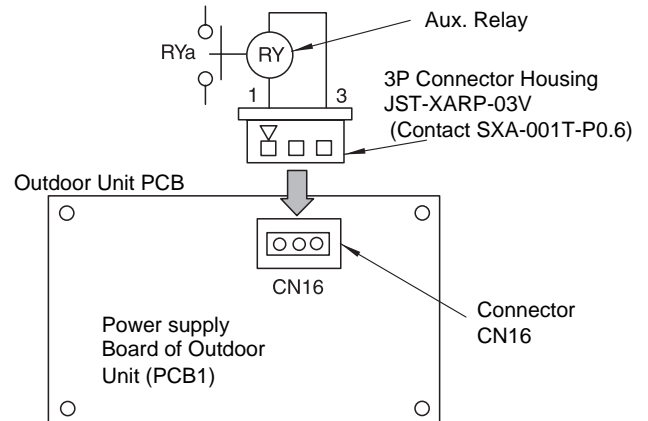

■ Picking Up Defrosting Signal

With this procedure the Defrosting signal can be picked up. The method is explained in the figure below. The required part is indicated in Table 4. 5. Connecting relay contactors (RYa) are closed at the time of defrosting.

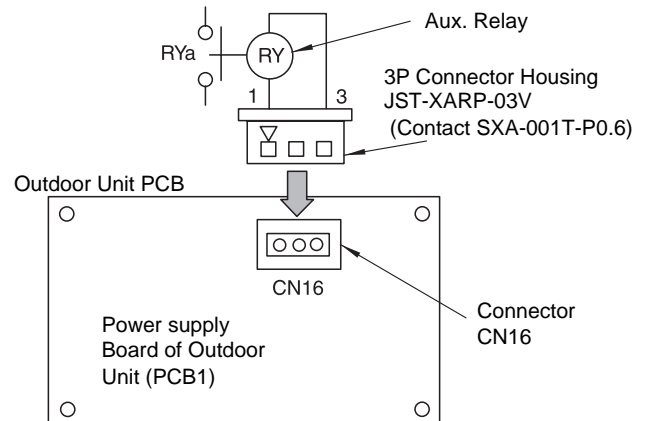

4.3. REMOTE CONTROL SWITCH (PC-2H2)

4.3.1. NAME OF PARTS

Liquid Crystal Display (L.C.D) Section

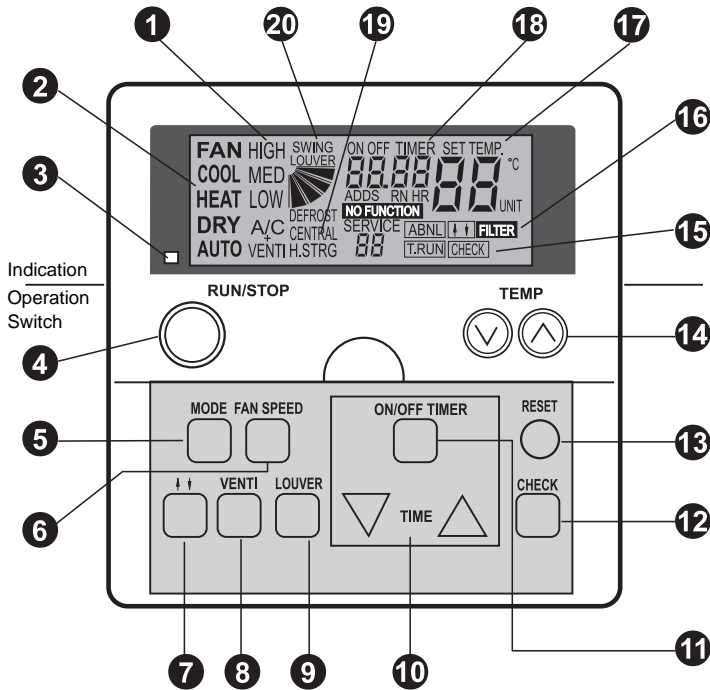

Liquid Crystal Remote Control Switch, PC-2H2 (Optional)

Model: PC-2H2
Order No.: 60299908

- 1 Fan Speed Indicator Ventilation Indicator**
Indicates the fan speed you have selected: (High/Medium/Low)
It indicates if Total Heat exchanger have been selected.
A/C only air conditioning
VENTI only ventilation
A/C + VENTI when both have been selected
- 2 Operation Mode Indicator**
Indicates the operation mode selected:
Fan, Cool, Heat, Dry, Auto (Cool/Heat)
- 3 Run Indicator (Red Lamp)**
- 4 RUN/STOP Switch**
- 5 MODE (Operation Mode Selection) Switch**
- 6 FAN SPEED (Fan Speed Selection) Switch**
- 7 Up & Down Panel Operation Switch**
- 8 VENTI(Ventilator Operation) Switch**

▲ CAUTION:

Press switches only with fingers. Do not press switches by any other item, as it may damage the switches.

- 9 LOUVER (Swing Louver Operation) Switch**
- 10 TIME (Time Setting) Switch**
Increases and decreases the Set Time for timer operation
- 11 ON/OFF TIMER Switch**
Used to activate or deactivate the timer operation
- 12 CHECK Switch**
- 13 RESET (Filter Reset Switch)**
After cleaning the air filter, press the "RESET" button. The filter indication **16** will disappear and the next filter cleaning time is reset. It also stops the run procedure.
- 14 TEMP (Temperature Setting) Switch**
- 15 T.RUN (Test Run Indication) Check (Check Indication)**
These Tests appears when "TEST RUN" or "CHECK" is being performed
- 16 ABNML (Alarm) Indicator "FILTER" Indicator**
- 17 SET TEMP (Set Temperature) Indicator**
- 18 ON/OFF Timer (Timer Operation Indicator) Alarm Code Indicator "NO FUNCTION" Indicator**
- 19 CENTRAL (Central Control Indicator)**
Indicates that central station or CS-Net is being performed
- 20 Swing Louver Indicator "DEFROST" Indicator**

Note:

Do not use this system as constant temperature and constant humidity control equipment.

In the case that the LOW fan speed is selected and outdoor temperature is higher than 21°C, excessive load is given to the compressor at heating operation. Therefore, set the fan speed at HIGH or MEDIUM, since safety devices may be activated.

When the system is started after a shutdown longer than approximately 3 months, it is recommended that the system be checked by your service contractor.

Turn OFF the main switch when the system is stopped for a long period of time. If the main switch is not turned OFF, electricity is consumed, because the oil heater is always energized during compressor stopping.

4.3.2. SIMULTANEOUS OPERATION

■ Simultaneous Indoor Unit Operation with Remote Control Switch

⚠ DANGER:
All power sources must be turned off!!

Up to 16 indoor units can be simultaneously controlled using one remote control switch. The operation mode such as fan, cooling or heating, the setting of air flow, the setting of temperature and the setting of run/stop can only be set uniformly for all units. However, on/off operation of each thermostat can be done individually. Defrosting, protective devices function, etc. are individually performed.

a. Perform wiring between indoor units as shown in the following figure.

- * The total length of the wire shall be 200m or shorter. (for 0.75mm² wire 500m or shorter)
- * Use the following three cable wire in the system parts.

Model	PRC-10E	PRC-15E	PRC-20E
Length	10m	15m	20m

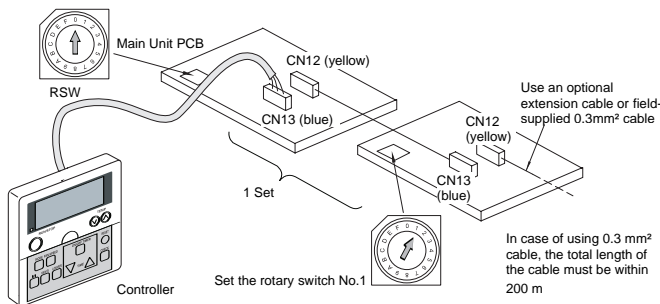

⚠ CAUTION:
When 0.3mm² wires are used, the length between units must be 100m or shorter, and the total length must be 200m or shorter. (When 0.75mm² wires are used, the total length can be extended up to 500m.)

- b. Connected unit control wires should not be installed parallel to 220-415V power cables. Fix them by utilizing bands. It is recommended, that cables be installed at least 30cm away from power cables or be put into grounded metal pipes.
- c. Set rotary switches RSW on the printed circuit boards of respective units as shown in the following figure.

⚠ DANGER:
Turn off all power sources!!

- **Setting of Rotary Switches:**
When indoor units are connected to the same outdoor unit, it is unnecessary to set rotary switches, because they are automatically addressed.

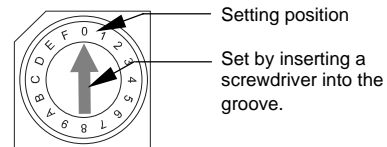

Unit n° 0	Unit n° 1	Unit n° 2	Unit n° 3
Unit n° 4	Unit n° 5	Unit n° 6	Unit n° 7
Unit n° 8	Unit n° 9	Unit n° 10	Unit n° 11
Unit n° 12	Unit n° 13	Unit n° 14	Unit n° 15

⚠ CAUTION:
Pay attention not to overlap addresses.

- d. Check Method of Number of Connected Units
Perform this check after finishing wiring, refrigerant piping, additional refrigerant charge and other items required for operation.

Test Running Mode

1. Turn ON the power sources of all units. Depress the CHECK switch and the MODE switch on the remote control switch simultaneously for three seconds or longer, to change the unit(s) to the test running mode. (Refer to the checking procedure by the CHECK switch.)

Number of Units Connected

2. When the number of units connected is indicated where usually the temperature is indicated, the system is functioning normally.

False Number of Connected Units is Indicated

3. When the indicated number of connected units is smaller than the actual number or zero, presumable causes are as follows:
The power source of some units is not turned ON.
Incorrect setting of unit numbers was performed.
Control wires between units or remote control switch were incorrectly connected regarding polarity and order.

Ending of Test Running Mode

- e. When the confirmation of the number of connected units and the wiring-checking are finished, end the test running mode by depressing the "RESET" switch.

4.3.3. OPERATION SYSTEM WITH TWO REMOTE CONTROL SWITCHES

- **By installing an additional remote control switch, a maximum of 16 units can be controlled from two different locations.**

Main and Sub Control Switch

Determine one of the two remote control switches to be the main switch and the other as a sub switch. Cut the jumper wire JP01 in the sub remote control switch as shown in the right figure.

Altering Method to Sub Control Switch
Cut Jumper Wire JP01 with Nippers

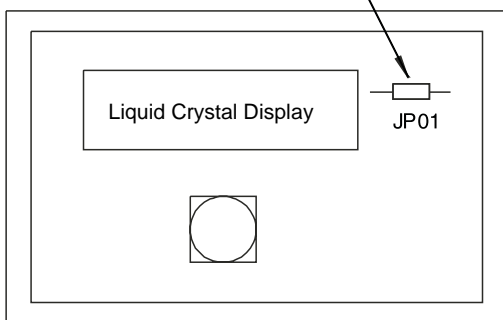

■ Wiring Method

- a. Perform wiring between units as shown in the following figure: (Three Unit Case)

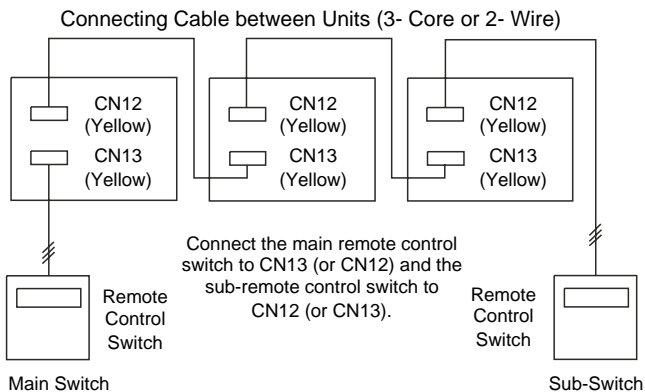

- b. Decide the number of units. The method should be the same as in "Simultaneous Indoor Unit Operation with One Remote Control Switch".

■ Checking the Main and Sub Remote Control Switches

Press the "CHECK" switch and the "RESET" switch simultaneously for more than 3 seconds, the main remote control switch is changed to the field setting mode, and the sub remote control switch is changed to the check mode.

▲ CAUTION:

*When a main remote control switch malfunctions, unit operation stops. Units cannot be operated with only a sub-remote control switch.
When a main switch and a sub-switch are simultaneously operated, the units will operate according to either one of the modes after 30 seconds.*

4.3.4. OPTIONAL FUNCTION SETTING

The remote control switch is changed to the optional setting mode by the following procedures.

■ Field Setting Mode

Check to ensure that the unit is stopped, press the "CHECK" switch and the "RESET" switch on the remote control switch simultaneously more than 3 seconds, and the remote control switch is changed to the field setting mode. When the remote control switch is at the field setting mode, the "SERVICE" is indicated and the "01" is flickers below the "SERVICE" indication.

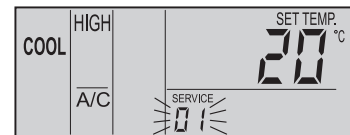

■ Optional Setting Mode

At the field setting mode as described in Field Setting Mode, press the "TEMP Δ" switch or the "TEMP ∇" switch and the number flickering below the "SERVICE" indication is changed (01 <=> 02). Set the flickering number at "01", leave this condition for 7 seconds or press the "CHECK" switch, and the remote control switch is changed to the optional setting mode.

■ Selection of Indoor Unit

a. At the optional setting mode, the indication on the remote control switch is changed as shown in the right figure.

- ① The indication of "01" is turned
- ② The address of the indoor unit which the optional function is to be set, is indicated at the segments for timer setting time indication, and the "ADDS" is indicated below.
- ③ The refrigerant cycle number of the indoor unit for which the optional function is to be set, is indicated at the segments for timer setting time indication, and the "RN" is indicated below.
- ④ The indication of the setting temperature is turned OFF.

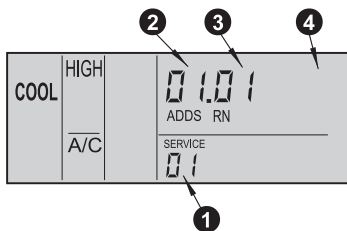

b. At the condition of the above item (a), press the "TEMP ∇" switch or the "TEMP Δ" switch of the remote control switch and the indoor unit for which the optional function is to be set, can be changed.

NOTES:

The indoor unit can be selected among the indoor units connected to the remote control switch.
In case that both the indications of the address and the refrigerant cycle number is "AA", the settings of all the indoor units is same.

c. After selecting the indoor unit, leave the condition for 7 seconds or press the "CHECK" switch, the remote control switch is changed to the optional setting mode.

■ Changing of Optional Functions and Setting Conditions

a. At the optional setting mode, the indication on the remote control switch is changed as shown in the right figure.

- ① The indications of "ADDS" and "RN" are turned OFF.
- ② The item number of the optional function is indicated at the segment for the setting temperature indication. Refer to the table in the next pages for the item numbers and the contents of the optional functions.
- ③ The setting condition of the optional function item is indicated at the segments for timer setting time indication. Refer to the table in the next pages and description of each items for the indication of the setting condition and the contents of the optional function.

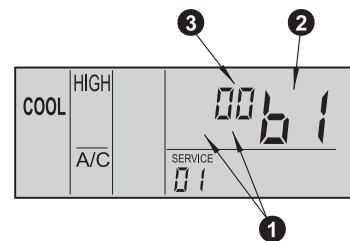

b. Press the "TIME ∇" switch or the "TIME Δ" switch, the optional function item is changed as shown below.

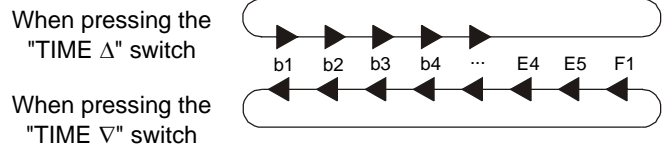

c. Press the "CHECK" switch, and the setting condition of the optional function is changed as shown below.

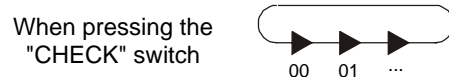

■ Selection of Other Indoor Unit

At the optional setting mode, press the "TEMP ∇" switch or the "TEMP Δ" switch, the condition of the remote control switch is changed so that the indoor unit can be selected to set the optional function described in the item (b) of "Selection of Indoor Unit".

■ Return from Optional Function Setting Mode

Press the "RESET" switch, the optional function setting is memorized and the mode is returned to the normal condition.

■ Setting Items of Optional Functions

No.	Items	Optional Functions	Individual Setting	Setting Condition	Contents
①	b1	Removal of Heating Temperature Calibration	○	00 01	Not Available Available
②	b2	Circulation Function at Heating Thermo-OFF	○	00 01	Not Available Available
③	b3	Enforced 3 Minutes Minimum Operation Time of Compressor	○	00 01	Not Available Available
④	b4	Change of Filter Cleaning Time	○	00 01 02 03 04	Standard 100 hours 1200 hours 2500 hours Not Indication
⑤	b5	Fixing of Operation Mode	×	00 01	Not Available Available
⑥	b6	Fixing of Setting Temperature	×	00 01	Not Available Available
⑦	b7	Fixing of Operation as Exclusive Cooling Unit	×	00 01	Not Available Available
⑧	b8	Automatic COOL/HEAT	×	00 01	Not Available Available
⑨	b9	Fixing of Air Volume	×	00 01	Not Available Available
⑩	C8	Thermistor of Remote Control Switch	○	00 01 02	Control by Indoor Suction Thermistor Control by Remote Control Thermistor Control by Average
⑪	F1	Automatic Setting for OFF Timer	×	00 01 02 ~ 23 24	No Function OFF Timer by 1 Hour OFF Timer by 2 Hour OFF Timer by 23 Hours OFF Timer By 24 Hours

NOTES:

As for optional functions with " × " at the individual setting, only when the "All Rooms" is selected to set the optional function, the setting condition can be changed. As for the items not indicated in the above table, the optional function is not available. Do not change the setting.

4.3.5. OPTIONAL FUNCTIONS OF REMOTE CONTROL SWITCH

① Removal of Heating Temperature Calibration

This function is utilized when the temperature settings of the remote control switch and the suction air temperature of the indoor unit are required to be equal.

In standard heating operation, the suction air temperature is higher than the room temperature, therefore the suction air temperature is calibrated -4°C.

(Indicated Setting Temperature = Suction Air Temperature -4°C → Return to 0 °C) This is useful when the thermistor at the suction side of an indoor unit is removed and installed in another place. The indicated setting temperature and the suction air temperature after removal of heating temperature calibration are as shown beside.

Indicated Temperature		Activating Temperature (°C)		
		When Cooling	When Heating / For Comp.	
			Standard	After Removal
18	ON	-	22	18
	OFF	-	24	20
20	ON	22	24	20
	OFF	20	26	22
22	ON	24	26	22
	OFF	22	28	24
24	ON	26	28	24
	OFF	24	30	26
26	ON	28	30	26
	OFF	26	32	28
28	ON	30	30	28
	OFF	28	32	30
30	ON	32	30	30
	OFF	30	32	32

2 Circulator Function at Heating Thermo-OFF

In case that the fan speed is changed to "LOW" tap at heating Thermo-OFF, there is a case that the room air is stratified because warm air stagnates near the ceiling. In this case, it is recommended that the circulator function explained below be utilized.

<Circulator Function>

The function keeps the fan speed at thermo-OFF at the same level as thermo-ON. In this case, air movement in the room will be kept on the same level as thermo-ON, ensuring a homogenous air distribution. In the case that an Auto Louver is equipped, this operation will be also held on when the heating is turned thermo-OFF.

NOTES:

Perceptions of coolness, heat and air flow are subject to personal tastes and behaviors. It is therefore recommended to discuss this with customers thoroughly and then to set the unit accordingly.

3 Enforced 3 Minutes Minimum Operation Time of Compressor

When a compressor frequently starts and stops in short intervals, this function should be used to guard the compressor. By setting this function, the mode of a minimum 3 minutes operation will be added. (The mode of a minimum 3 minutes stoppage is standard.) In case of SET-FREE, this function is standard even when setting is not available.

NOTES:

When the safety device is activated or the "ON/OFF" switch is pressed, the compressor is stopped immediately.

4 Change of Filter Cleaning Time

The period for filter sign indication is set for each indoor unit model when shipping. The filter sign is indicated according to the filter cleaning time (Factory-Setting). However, this filter cleaning time can be changed depending on the condition of the filter as shown in the table below.

	Period for Filter Sign Indication			
	Approx 100 hrs	Approx 1,200 hrs	Approx 2,500 hrs	No Indication
In Case of 4-Way Cassete Type	○	⊙	○	○
Liquid Crystal Display on Remote Control witch	01 b4	02 b4 or 00 b4 ❖	03 b4	04 b4

- ⊙: Factory-Setting
- : Changed Setting Period
- ❖: In the case of RPK model, the factory setting is 200 hrs.

5 Fixing of Operation Mode

This function is utilized when changes in operation modes are not required. When this function is valid, the operation mode which has been set cannot be changed.

6 Fixing of Setting Temperature

This function is utilized when changes in setting temperature are not required. When this function is valid, the setting temperature which has been set cannot be changed.

7 Fixing of Operation as Exclusive Cooling Unit

This function is utilized when exclusive cooling operation is required. This function invalidates the heating operation and the automatic COOL/HEAT operation, as the operation of exclusive cooling unit.

8 Automatic COOL/HEAT Operation

This function is utilized to operate the unit with changing cooling and heating operation automatically. This function is invalid when the outdoor unit is cooling only model or the function of "Fixing Operation as Exclusive Cooling Unit" is valid.

9 Fixing of Fan Speed

This function is utilized to fix the fan speed. When this function is valid, the fan speed is not changed by the remote control switch.

10 Remote Control Thermistor

This function is utilized to control the unit by the built-in thermistor of the remote control switch (remote control thermistor) instead of the thermistor for suction air. Set this function at "01" or "02" when utilizing this function. However, even when this function is set at "01" or "02", the detecting temperature is abnormal due to the failure of the remote control thermistor, etc., the thermistor to be used is changed to the thermistor for suction air of the indoor unit automatically.

11 Automatic OFF Timer Setting

This function is utilized to set the OFF timer function automatically when the unit is started by the remote control switch. During operation with the automatic OFF timer setting function, the cancellation of the OFF timer and the changing of the setting period for OFF timer can not be performed. However, the OFF timer function is cancelled when the unit is stopped.

When the unit is operated again after stoppage, the setting period for OFF timer is the period set by the optional setting.

The setting condition and the setting period for OFF timer are as shown below.

Setting Condition	Setting Period for OFF Timer
00	Function Invalid
01	1 Hour
02	2 Hour
03	3 Hour
~	~
22	22 Hour
23	23 Hour
24	24 Hour

4.3.6. INDICATION OF ADDRESS (ADDS) AND REFRIGERANT CYCLE NUMBER (RN)

The address and the refrigerant cycle number can be indicated on the liquid crystal display of the remote control switch.

■ Model Indication Mode

During operation or stoppage in normal condition, press the "TEMP ▽" switch and "TEMP ▲" switch simultaneously for more than 3 seconds.

The remote control switch is changed to the model indication mode.

■ Indication of Unit Model

a. At the model indication mode, the following items of information about the indoor unit connected to the remote control switch are indicated for 3 seconds serially.

- ❶ Address and Refrigerant Cycle Number
- ❷ Model Code of Outdoor Unit

In case of group setting for the plural indoor units by the remote control switch, the above items ❶~❷ are indicated for each indoor unit.

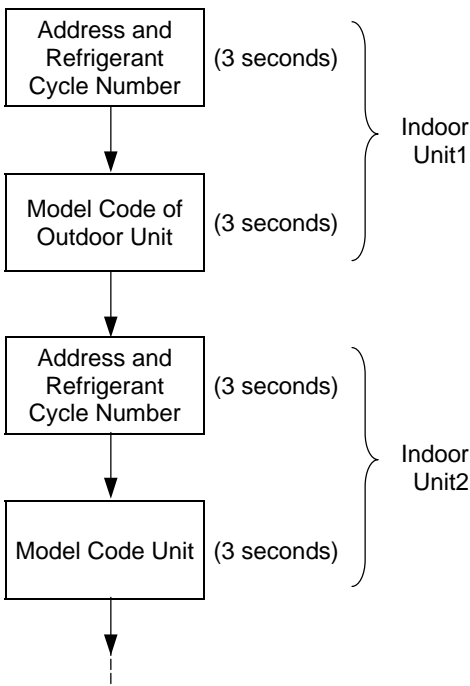

The indication of the above items ❶~❷ for all the indoor units connected the remote control switch is completed, the remote control switch is returned to the normal condition.

b. Indication of Address and Refrigerant Cycle Number
The indication of the address and the refrigerant cycle number of the indoor unit shown in the below figure.

- ❶ The address of the indoor unit is indicated at the segments for timer setting time indication and the "ADDS" is indicated below the address indication.
- ❷ The refrigerant cycle number of the indoor unit is indicated at the segments for timer setting time indication and the "RN" is indicated below the refrigerant cycle indication.
- ❸ The indication of the setting temperature is turned OFF.

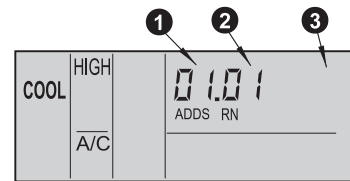

c. Indication of Model Code

The indication of the model code is shown in the below figure.

- ❶ The model code of the outdoor unit connected to the indoor unit indicated in the above item ❶ is indicated at the segments for timer setting time indication.
* Model Code of SET- FREE: "F"
- ❷ The number of the indoor units in the same refrigerant cycle of the indoor unit indicated in the above item ❶ at the segments for timer setting time indication.
- ❸ The indication of the setting temperature is turned OFF.

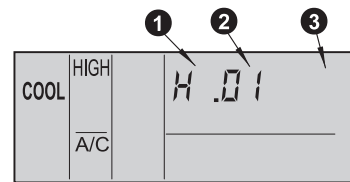

4.4. OPTIONAL WIRELESS REMOTE CONTROL SWITCH, PC-LH3

4.4.1. NAME OF PARTS

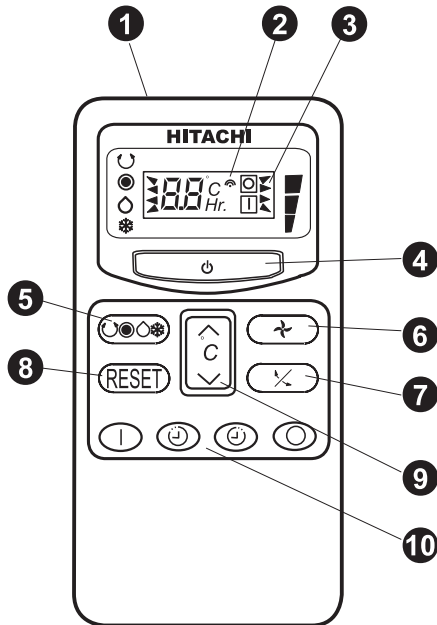

Model: PC-LH3
Order No.:60299909

This controller is used to send commands about operation mode, timer setting, etc. to the indoor unit. Face the transmitter of the controller toward the receiver of the indoor unit and press the switch of required operation so that commands (by infrared rays) are sent to the indoor unit. The distance for transmitting is approximately 5 meters as a maximum. (The capable distance for transmitting will get shorter in case that the transmitting angle is not vertical to the receiver or an electronic type light is used in the room, etc.)

- 1 Transmitter:**
Face this part vertically to the receiver of the indoor unit when sending commands. The transmitting mark on the liquid crystal display blinks when sending commands.
- 2 Transmitting Mark:** "☺"
- 3 Liquid Crystal Display:**
The set temperature, timer operation, position of air louver, operation mode, air flow mode, etc. are indicated.

(The displayed figure shows all indication items for explanation only. Therefore, the indication in actual operation is different)

- 4 RUN/STOP Switch:** "⏻"
The operation is started when this switch is pressed and the operation is stopped when this switch is pressed again.
- 5 MODE Selection Switch** "☺☻☼☽☾☿"
The operation mode can be selected by this switch. The operation mode is changed in the following order by pressing this switch; AUTO "☺" • HEAT "☻" • DRY "☼" • COOL "☽" • FAN.
The "◀" mark indicates the selected mode (No indication for FAN operation)
- 6 FAN SPEED Select Switch:** "↗"
The fan speed can be selected by this switch. The fan speed is changed in the following order by pressing this switch: HIGH "■" • MEDIUM "▒" • LOW "□". The mark "▶" indicates the selected mode (the fan speed is fixed at LOW "▒" when DRY operation).
- 7 LOUVER ANGLE Switch :** "↘"
The air flow angle of the air louver and auto-louver operation can be set by this switch. The angle of the air louver can be fixed at 7 positions (5 position for COOL and DRY operation) from the horizontal position "1" to the lowest position "7" (the lowest position "5" for COOL and DRY operation). The angle is changed in the following order by pressing the switch: "1" • "2" • "3" • "4" • "5" • "6" • "7".
When the auto-louver operation is selected, "R" is indicated"
- 8 TEMP Switch :** "°C"
The setting temperature can be changed by this switch
- 9 RESET Switch:** "RESET"
(1) This switch is used to turn OFF the "FILTER" lamp of the indication part of the indoor unit after cleaning of the filter is finished.
(2) This switch is used to cancel control stoppage when the cause of abnormality is removed after the unit is stopped by protection devices, etc.
- 10 TIMER Switches:** "1", "⏻", "⏪", "⏩"
The timer operation is set by these switches. The setting time can be changed by pressing the ON "⏻" or OFF "⏪" switch, and the time is set by pressing the SET "1" switch. The timer operation is canceled by pressing the CANCEL "⏩" switch.

4.4.2. IDENTIFYING OF INDOOR UNITS INSTALLED SIDE BY SIDE

NOTES:

This function is not available in case of simultaneous operation mode.

When installing two (2) indoor units side by side, the commands from the wireless remote control switch can be received by both the indoor units.

- a. When installing two (2) indoor units (A and B) side by side, set one unit identified by the following method.

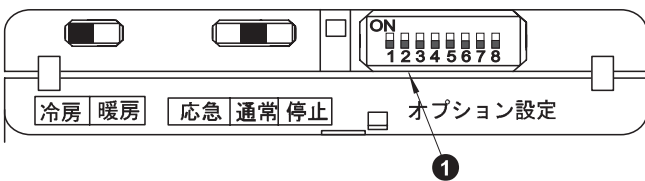

CAUTION:

Turn OFF the power source before performing the following procedures.

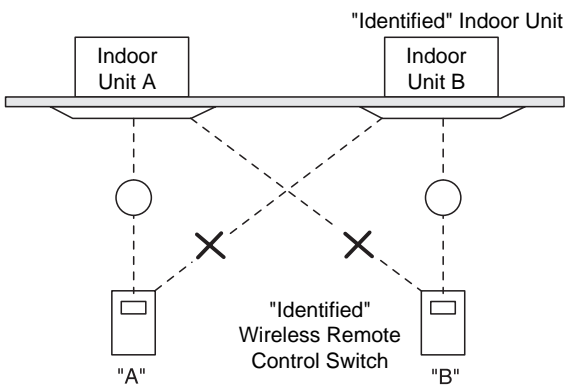

- b. Open the cover of the receiver part of the indoor unit to be identified (B unit) and set the dip switch No.8 to the ON position (set at OFF position at factory).
- c. Identify the wireless remote control switch for the identified indoor unit.
- ① Press the "I" switch and the "O" switch simultaneously more than 3 seconds. When "b" is indicated on the liquid crystal display of the wireless remote control switch, the unit is identified.
 - ② Press the "I" switch and the "O" switch simultaneously more than 3 seconds again. When "A" is indicated on the liquid crystal display of the wireless remote control switch, the identification of the unit is canceled.

- d. Set the rotary switch (RSW) on the indoor PCB of the indoor unit B as shown in the right figure.

RSW

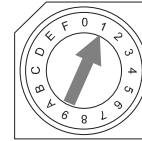

- e. When the above procedures b, c and d are performed, only the identified indoor unit corresponds to the commands from the identified wireless remote control switch.
- f. When canceling the identification of the unit, set the dip switches of the receiver part and the setting of the rotary switch (RSW) on the indoor PCB at the former position and cancel the identification of the unit

4.4.3. SIMULTANEOUS OPERATION

Up to 16 indoor units can be simultaneously controlled using one wireless remote control switch. In this case, only two (2) air panels for wireless control can be connected. Apply the simultaneous operation only in the case that the plural indoor units are installed in the same room as shown in the below figure.

Do not apply the simultaneous operation for the indoor units installed separately in different rooms. Some units may be left without turning OFF the power source.

- Control Example Simultaneous Operation of Multiple Indoor Units:

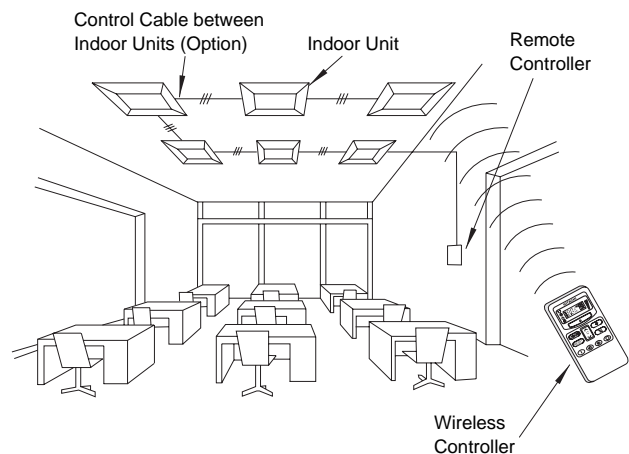

CAUTION:

Turn OFF all the power source before wiring and setting the dip switches.

- a. Installation of Air Panel for Wireless Control
 In case of simultaneous operation of plural (up to 16) units by the wireless remote control switch, apply the air panel for wireless control only to the unit to be operated, and apply the standard panels (for wired control) to other units. In case of applying plural air panels for wireless control, up to 2 air panels for wireless control can be used.

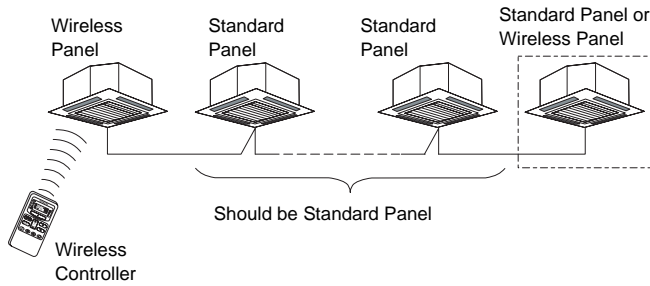

In case of applying two (2) air panels for wireless control, the setting of main and sub receiver part is required. Refer to the item 4.4.5 "Optional Function Setting" for the dip switch setting procedures.

- b. Perform wiring between indoor units as shown in the figure below.
 * The total length of the wire shall be 200m or shorter. (for 0.75mm~ wire 500m or shorter)
 * Use the following three cable wire in the system parts.

Model	PRC-10E	PRC-15E	PRC-20E
Length	10m	15m	20m

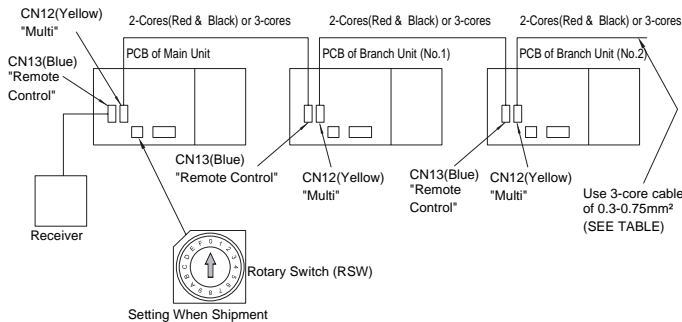

- c. Connected unit control wires should not be installed parallel to 220-415V power cables. Fix them by utilizing bands. It is recommended that cables be installed at least 30cm away from power cables or be put into grounded metal pipes.

- d. Set the Rotary Switches (RSW) on the printed circuit boards of respective units as shown in the next table.

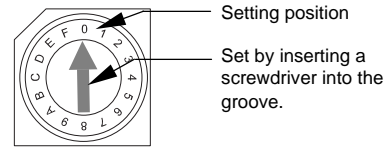

Unit n° 0	Unit n° 1	Unit n° 2	Unit n° 3
Unit n° 4	Unit n° 5	Unit n° 6	Unit n° 7
Unit n° 8	Unit n° 9	Unit n° 10	Unit n° 11
Unit n° 12	Unit n° 13	Unit n° 14	Unit n° 15

CAUTION:

If the setting of the Rotary Switches (RSW) is not performed correctly, the operation LED (Red) on the panel flickers and the unit can not be operated due to the abnormal setting of the indoor unit number.

- e. Identify the indoor units by attaching the nameplates of unit number (field-supplied) to the indoor units when setting the rotary switches (RSW) for each indoor unit.

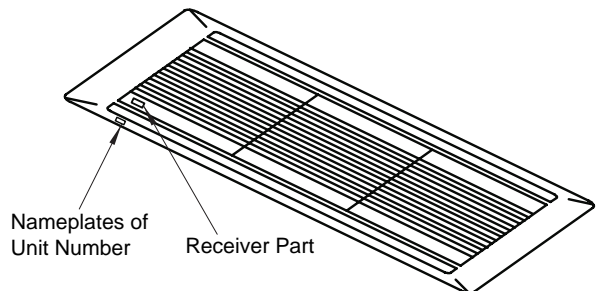

- f. Attach the nameplate of unit number for outdoor unit (field-supplied) corresponding to the unit number of the indoor unit.

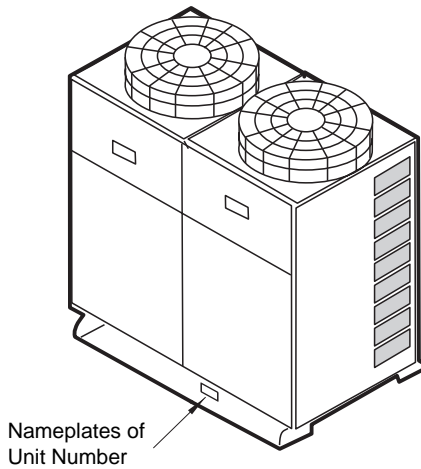

4.4.4. EMERGENCY OPERATION

In case that the unit is required to be operated when the wireless remote control switch is out of battery and can not function, etc., the unit can be operated by the emergency operation switch. The cooling operation and the heating operation are available for the emergency operation.

CAUTION:

Turn OFF the power source of the unit before performing the emergency operation

- Open the cover of the receiver part or the grille of panel.
- Set the switch ❶ to the "COOLING" or "HEATING" position.
- Set the switch ❷ (emergency operation switch) to the "EMERGENCY" position.
- Close the cover of the receiver part and turn ON the power source of the unit.

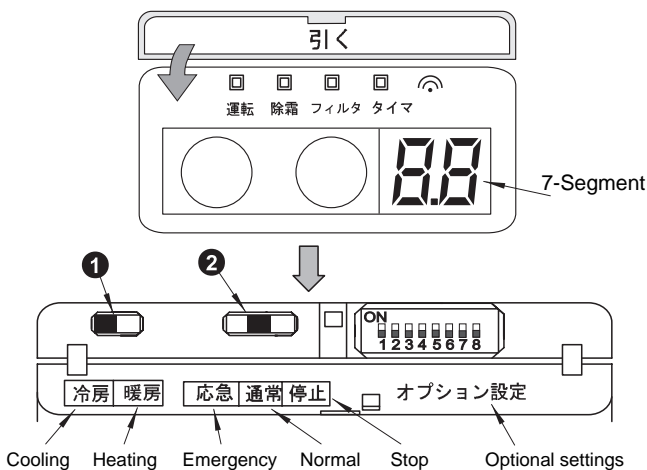

- e. The unit is operated.
Operating Condition

Operation	Cooling	Heating
Setting Temperature	21 °C	30 °C
Air Flow Mode	High	High

When operating the unit by the wireless remote control switch again, set the switch ❷ (emergency operation switch) to the "NORMAL" position.

NOTE:

For stopping the unit operated by the wireless remote control switch, the unit can be stopped by setting the switch ❷ (emergency operation switch) to the "STOP" position instead of turning OFF the power source of the unit.

4.4.5. OPTIONAL FUNCTION SETTING

The following optional functions can be set by the dip switches of the receiver part.

- Change of Filter Cleaning Time
- Muffling Buzzer Sound
- Removal of Heating Temperature Calibration
- Circulator Function at Heating Thermo-OFF
- Setting of Main and Sub Receiver Part
- Identifying of Indoor Units Installed Side By Side

CAUTION:

Turn OFF all the power sources before setting the dip switches

- Open the cover of the receiver part or the grille of panel. Refer to the receiver kit installed in the indoor unit for

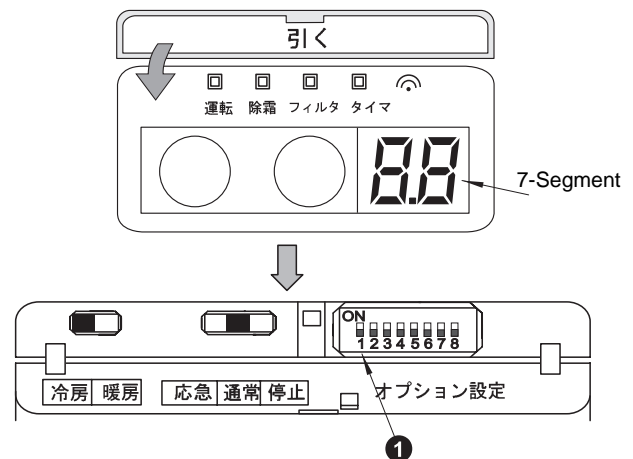

- b. Set the dip switches ❶ as shown in the table below.
After dip switch setting, close the cover of the receiver part or the grille of panel.

Optional Function		Dip Switch							
		1	2	3	4	5	6	7	8
Filter Option	Standard	×	×	×	-	-	-	-	-
	100 hours	○	×	×	-	-	-	-	-
	1200 hours	×	○	×	-	-	-	-	-
	2500 hours	○	○	×	-	-	-	-	-
	No indication	○	○	○	-	-	-	-	-
Muffing Buzzer Sound		-	-	-	○	-	-	-	-
Removal of Heating temperature Calibration		-	-	-	-	○	-	-	-
Circulator Function at Heating Thermo-OFF		-	-	-	-	-	○	-	-
Setting of Sub Receiver Part		-	-	-	-	-	-	○	-
Identifying Of Indoor Units		-	-	-	-	-	-	-	○

○ : ON × : OFF - : ON or OFF booth available

4.4.6. OPTIONAL FUNCTIONS OF WIRELESS REMOTE CONTROL SWITCH

■ Change of Filter Cleaning Time

The filter sign (LED; Yellow) of the receiver part is set to turn ON after the total operation period is over 1,200 hours approximately (Factory-Setting). (In case of the RPK model, the factory-setting is 200 hrs.) However, this filter cleaning time can be changed depending on the condition of the filter.

■ Removal of Heating Temperature Calibration

Refer to 4.3.5 (1) for the details.

■ Circulator Function at Heating Thermo-OFF

Refer to 4.3.5 (2) for the details.

■ Identifying of Indoor Units Installed Side By Side

Refer to the item 4.4.2 "Identifying of Indoor Units Installed Side By Side".

■ Setting of Main and Sub Control Switch

Refer to the item 4.4.3 "Simultaneous Operation".

4.5. 7-DAY TIMER (PSC-3T)

4.5.1. NAME OF PARTS

By plugging in this timer to the optional remote control switch, daily ON/OFF operation control throughout the week is available.

7-Day timer has power failure back-up dry cell. The ON/OFF control is three times in a day as a maximum and the setting is available every minute.

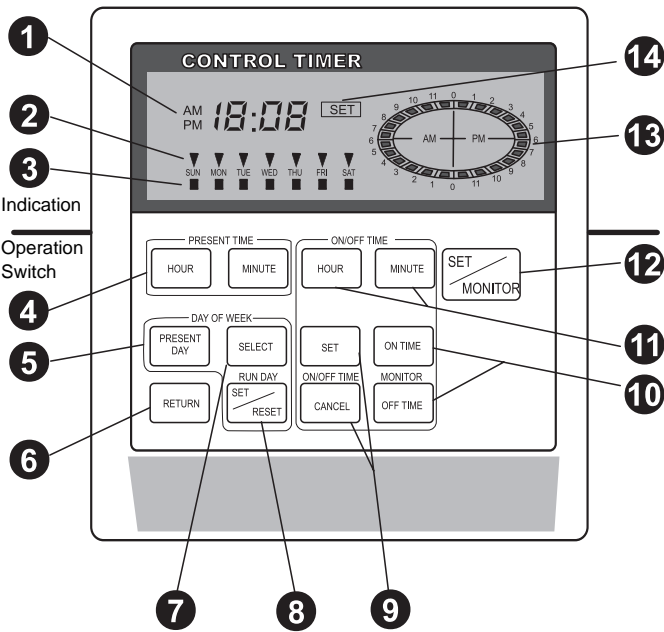

Model: PSC-3T
Order No: 60299725

- 1 Indication of Present Time and ON/OFF Setting Time**
This indicates the present time and On or Off setting time.
- 2 Indication of Present Day of the week**
This indicates the present day of the week
- 3 Indication of running Day of a week.**
Whenever the running day is set, this light is on.
- 4 Setting Switch of Present Time**
Present time is set by switch at "CLOCK" Mode.
- 5 Setting Switch of Present Day of a Week.**
Present day of week is set by this switch at "CLOCK" Mode.
- 6 Return Switch for Present Time, Present Day, Running Day and ON/OFF Time.**
In the case that this switch is depressed and the other switch is simultaneously depressed at "SETTING" mode or "CLOCK" mode, the "PRESENT TIME", "PRESENT DAY", "RUN DAY" and "ON/OFF TIME" return to normal operating Mode.

Functions

The 7-day timer provides the following functions:

- 1 ON/OFF Setting Time in a Week
- 2 ON/OFF Setting in available three times a day
- 3 Present time is indicated
- 4 Running time is indicated.

- 7 Selection Switch for Running Day of a Week**
Running days of a week are selected by this switch. The "▼" mark blinks at the position of the required running day.
- 8 Set/Reset Switch for Running Day of a Week**
By depressing this switch, the selected running days of a week are set or reset.
- 9 Set/Cancel Switch for ON/OFF Time**
By depressing the "SET" switch after adjusting the "ON TIME" or "OFF TIME" switch to the required time, the "ON TIME" or "OFF TIME" is set
- 10 Monitor Switch of ON Time and OFF Time**
By depressing this switch at setting mode, the Present Time and On/Off setting time is indicated.
- 11 Setting Switch of ON/OFF Time**
On or Off time of running operation is set by this switch.
- 12 Change Switch of Operation Mode**
"SETTING" mode, "MONITOR" mode and "CLOCK" mode are set by this switch.
In the case that "SET" is indicated after depressing this switch, the control is changed to "SETTING" mode.
If "SET" indication is turned off, this indicates "MONITOR" mode.
When this switch is continuously depressed for longer than 3 seconds at the "MONITOR" Mode, the "SET" indication blinks and "MONITOR" Mode appears.
- 13 Indication of Running Time Schedule and Remaining Running Time.**
In case of "MONITOR" Mode, the operation time schedule is indicated.
En case of "CLOCK" Mode, the remaining running time is indicated.
- 14 Indication of Mode selection.**
In the case that "SET" is not shown, this indicates "MONITOR Mode".
In the case that "SET" is shown, this indicates "SETTING" Mode.
In the case that "SET" blinks, this indicates "CLOCK" Mode.

CAUTION:

Press switches only with fingers. Do no press switches by any other item, as it may damage the switches

4.5.2. OPERATION PROCEDURE FOR RUNNING PATTERN

Setting	1 Supply Power to the Unit	
	2 Setting the present Day: Depress the "SET/MONITOR" switch for more than 3 (three) seconds. The "SET" indication blinks. This indicates the "CLOCK" mode. Set the "▼" mark with present day by depressing the "PRESENT DAY" switch.	
	3 Setting the present Time: Set the "Present Time and ON/OFF Setting Time" indication with the present time by depressing the "HOUR" and "MINUTE" switches on the "ON/OFF TIME" switch.	
	4 Fixing the Present Day and Present Time: The present day and the present time are fixed by depressing the "SET/MONITOR" switch. The "CLOCK" mode is changed to the "MONITOR" mode and the "SET" indication is turned OFF.	
	5 Setting the Operation Mode: By depressing the "SET/MONITOR" switch, operation mode is changed to the "SETTING" mode and the "SET" indication is turned ON	
	6 Setting Running Day of a week: Set the "▼" mark at the required running day of a week by depressing the "SELECT" switch. Depress the "SET/RESET" switch, the "■" mark will be turned ON at the required running day. When the unit is not required to be started, "■" mark should be turned OFF	
	7 Setting or canceling ON/OFF Time: The "ON/OFF TIME" is adjustable by depressing the "HOUR" and "MINUTE" switches of the "ON/OFF TIME" switch after depressing the "ON TIME" or "OFF TIME" switch of the "MONITOR" switch. In the case that "ON TIME" is set or cancelled, depress the "SET" or "CANCEL" switch after adjusting the "ON TIME". In the case that "OFF TIME" is set or cancelled, depress the "SET" or "CANCEL" switch after adjusting the "OFF TIME". By the above procedure, three patterns in a day as a maximum can be set.	

4.5.3. OPERATION PROCEDURE FOR OPERATION PATTERN

Monitoring	1 Setting Control Mode: By depressing the "SET/MONITOR" switch, the "SET" indication is turned OFF and the "MONITOR" mode appears	
	2 Setting Day of a week for Monitoring. By depressing the "SELECT" switch of the "DAY OF WEEK" switch, the "▼" mark is set at the required day of a week.	
	3 Monitoring ON/OFF Time: In the case that the "ON TIME" is monitored, depress the "ON TIME" switch of the "MONITOR" switch. In the case that the "OFF TIME" is monitored, depress the "OFF TIME" switch of the "MONITOR" switch.	

4.6. OPTIONAL CENTRAL STATION (PSC-3S1)

4.6.1. NAME OF PARTS

This central station is able to control simultaneously 16 indoor units as one group and at maximum 16 groups (totally 256 indoor units).

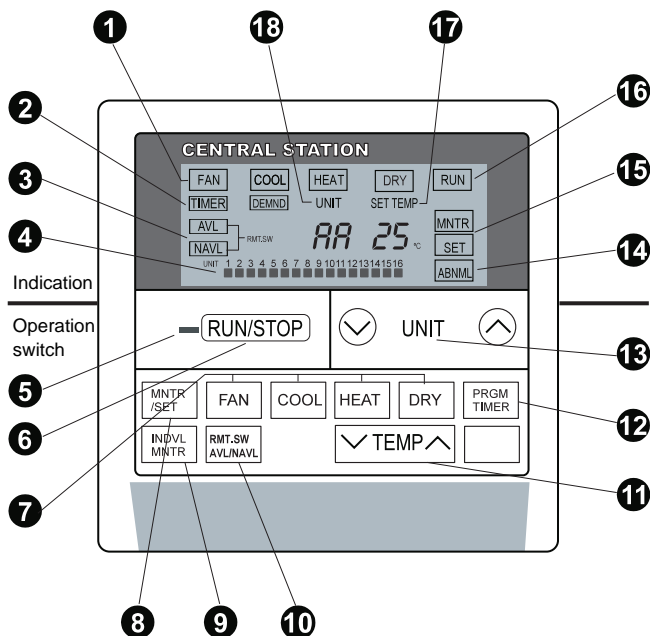

Model: PSC-3S1
Order No: 60299729

- 1 Mode Indication**
FAN, COOL, HEAT or DRY is indicated
- 2 7-Day Timer Indication**
By touching PRGM TIMER switch, TIMER is indicated.
(With 7-Day Timer).
- 3 Control Switch Selection**
By touching RMT.SW AVL/NAVL, available (AVL) or not available (NAVL) is indicated.
- 4 Operation Status Indication**
Operation Status of each unit is indicated
■: ON, □: OFF
- 5 Run indication (red light)**
This light is ON when one or more units are operating
- 6 RUN/STOP Switch**
By touching this switch, the unit is started or stopped.
- 7 Mode Switch**
By touching this switch, FAN COOL, HEAT, DRY operation is selected.

Note: The set part and the part which corresponds to actual operation are indicated
In the case that an exclusive cooling unit is controlled by this Central Station, HEAT operation is not available even if the above switches are used.

8 MNTR/SET Switch

When setting mode is selected, the following are available.

- Setting of FAN, COOL, HEAT or DRY operation
- Room Temperature Setting
- Permission or Prohibition of Control Remote by Remote Control Switch
- Setting, whether 7-Day timer control is required or not

Note:

When monitoring mode is selected, the above mentioned operation modes and setting temperature are indicated.

9 INDVL MNTR Switch

By pressing this switch, operation status of the selected group (or unit) is indicated.

■: ON, □: OFF

During individual monitoring operation, indication of "UNIT" is OFF.

10 RMT.SW AVL/NAVL Switch

By touching this switch, control by each remote control switch is permitted or not
AVL Indication: Control by each remote control and the Central Station is available.
NAVL Indication: Control only by Central Station is available.

11 TEMP Switch

By touching "▲" or "▼", the setting temperature is increased or decreased by 1 °C.
The maximum setting is 30 °C and the minimum is 17 °C.

12 PRGM TIMER Switch

This switch is used only when 7-Day Timer is used.

13 UNIT Switch

Your required unit can be selected by touching "▲" or "▼" switch to change operation mode or setting temperature. All units can be set at the same mode when AA is selected.

14 Alarm

ABNML is indicated when the operation is abnormal

15 MODE Indication

Setting mode or monitoring mode is indicated

16 RUN

RUN status is indicated

17 Temperature Indication

This indicated a setting temperature.

18 Unit No. Indication

The Unit No. is indicated.

CAUTION:

Press switches only with fingers. Do not press switches by any other item, as it may damage the switches

4.6.2. SYSTEM

CAUTION:

The following functions by the Central Station are not available. Therefore, special attention to the following is required when designing your systems.

1. Fan speed setting of each indoor unit is not available.
2. Setting of the automatic swing louver is not available (only for indoor units with the automatic swing louver).
3. Resetting of "FILTER" of each remote control switch is not available.
4. The Central Station does not indicate alarm codes.
5. No "FILTER" indication on the Central Station is available
6. No checking function on systems is available.
7. Unit number setting of each indoor unit is not available.

■ **System of up to 16 units**

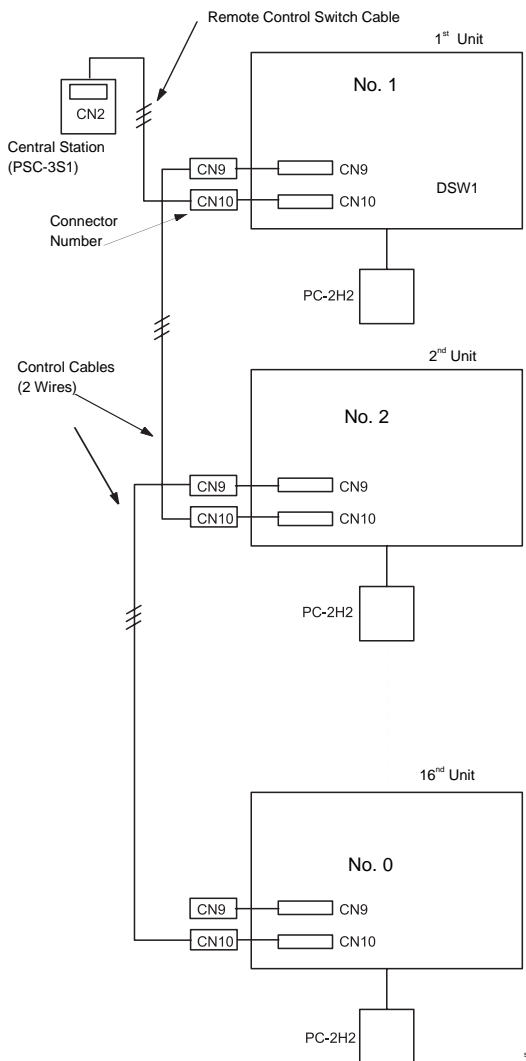

■ **Setting of Rotary Switches**

Set the unit number of all the units using the rotary switch (DSW1) of indoor unit PCB.

WARNING:

*Do not set the same indoor unit number in the same refrigeration cycle.
If the same number exists, an alarm code of 35 appears.
Always start from no. 1 for the main indoor unit*

Unit n° 0	Unit n° 1	Unit n° 2	Unit n° 3
Unit n° 4	Unit n° 5	Unit n° 6	Unit n° 7
Unit n° 8	Unit n° 9	Unit n° 10	Unit n° 11
Unit n° 12	Unit n° 13	Unit n° 14	Unit n° 15

Note: The above setting is same with the setting when the remote control switch (PC-2H2) is used.

■ System of more than 16 units

Layout and Electrical Wiring

In the case that more than 16 indoor units including 16 units up to 256 units are controlled by the Central Station, 16 groups as a maximum can be controlled by this Central Station and each group can consist of 16 units as a maximum.

The ON/OFF control of each group is available.

Furthermore, the operation status of all indoor units can be monitored by the Central Station.

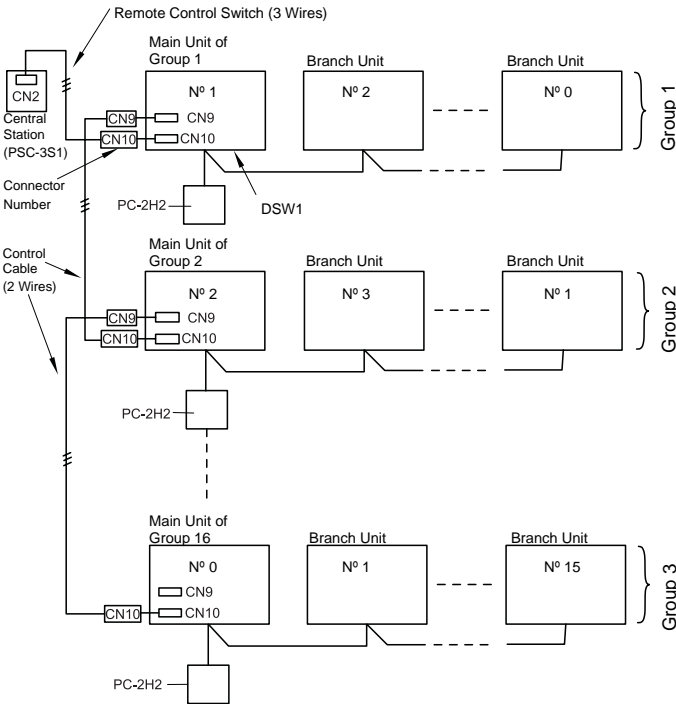

■ Setting of Rotary Switches

Set the number by using the rotary switch, DSW1 on the PCB in the indoor units. Firstly set the unit number for the main unit in group 1 and secondly set the unit numbers for the branch units one by one according to the figure below. Next, set the unit number for the main unit in group 2 and set the unit numbers for the branch units one by one. However, please note that the unit number for the main unit in group 2 should be set from the next number as shown below. Repeat this work for the remaining units.

⚠ WARNING:

- Do not set the same indoor unit number in the same refrigeration cycle. If the same number exists, an alarm code of 35 appears.
- Do not set the same indoor unit number in the main indoor units. Always start from No.1 for the main indoor units.
- Do not use No.0 setting for the first main indoor unit.

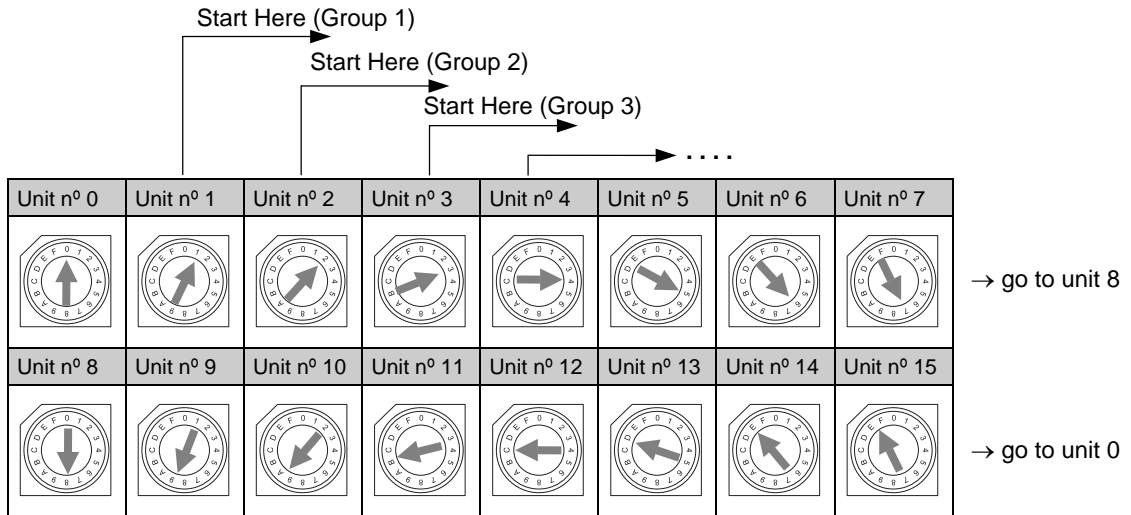

4.6.3. OPERATION PROCEDURE FOR CENTRAL STATION

Precautions for Operation

- **Battery Backup**
The central station (multi-function centralized controller) has a built-in battery which is used to store the operation patterns for up to 10 days after power is turned off. After the operation patterns are set, the air conditioner can be operated by a brief period using the [RUN/STOP] switch.
- **Unit Number Allocation Table**
The central station unit number allocation table is supplied together with this controller. It is recommended to enter the installation location of each unit in the table and keep it near the controller for easy management. Use the table thoroughly.
- **Connection to the Control Timer (PSC-3T)**
By connecting the control timer (7-Day timer) to the central station (multi-function centralized controller), the timer operation can be performed.

⚠ ATTENTION:

- The following functions at the Central Station are not available. Therefore, special attention to the following is required when designing systems.
- Fan speed setting of each indoor unit is not available.
 - Setting of the automatic swing louver is not available (only for indoor units with the automatic swing louver).
 - Resetting of "FILTER" of each remote control switch is not available.
 - The central Station does not indicate alarm codes.
 - "FILTER" indication on the Central Station is not available.
 - Checking function on systems is not available.
 - Unit number setting of each indoor unit is not available.

■ OPERATION PROCEDURE FOR SETTING (OR CHANGING) OPERATION PATTERNS

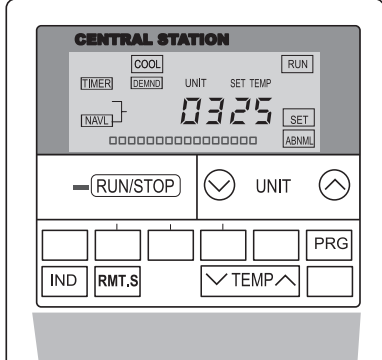
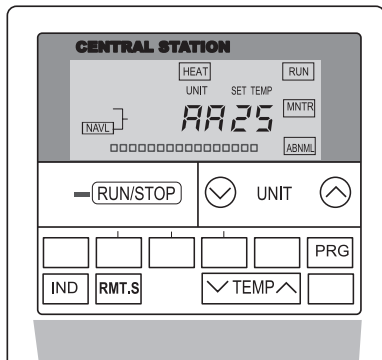
Mode Setting	<ol style="list-style-type: none"> 1 Press the mode selection switch [MNTR/SET] to select the [SET] mode. 2 Press the unit selection switch [UNIT] (⏴ or ⏵) to select the unit number to be set. (When setting all the units simultaneously, select the "AA" indication"). 3 Press one of the operation switches [FAN], [COOL], [HEAT] or [DRY] to select the operation mode. 4 Press the temperature adjustment switch [TEMP] (⏶ or ⏷) to set the temperature. (In the [FAN] mode, there is no need to set the temperature). The temperature range which can be set is from 17 °C to 30 °C. When the temperature is not set by the multi-function centralized control (the temperature is set by the individual remote control switch), set the temperature to 17 °C or 30 °C and press and hold the ⏴ or ⏵ switch for more than 3 seconds to display "- -". 5 When the timer operation is to be performed by an optional control timer, press the 7-day timer selection switch [PRGM TIMER] to select the [TIMER] mode. 6 When the operation by the individual remote control switch is not required, press the remote control selection switch [RMT.SW AVL/NAVL] to select "NAVL". 7 Press the [RUN/STOP] switch to set RUN or STOP. 	
Monitor	<p>By doing this, the operation choices are set. However, the operation choices cannot be sent to the unit in this status. Press the mode selection switch [MNTR/SET] to select the [MNTR] mode.</p> <p>Note: When the switch is left unpressed for more than 1 minute in the [SET] mode, the mode will automatically change to the [MNTR] mode</p>	

■ OPERATION PROCEDURE FOR SIMULTANEOUS RUN/STOP OPERATION

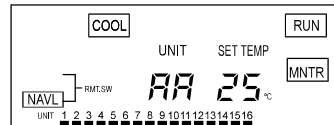
Mode Monitor	<ol style="list-style-type: none"> 1 Press the unit selection switch [UNIT] (⏴ or ⏵) to display "AA". 2 In the [RUN/STOP] switch is pressed when the operation of more than one unit is set, all the units will stop simultaneously. 3 If the [RUN/STOP] switch is pressed again, all the units will operate simultaneously. 	
---------------------	---------------------------------------------------------------------------------------------------------------------------------------------------------------------------------------------------------------------------------------------------------------------------------------------------------------------------------------------------------------	---------------------------------------------------------------------------------------

■ OPERATION PROCEDURE FOR INDIVIDUAL RUN/STOP OPERATION

Mode Monitor	<ol style="list-style-type: none"> 1 Press the [UNIT] switch (⏴ or ⏵) to set the unit number. 2 When [RUN/STOP] switch is pressed in this status, the unit will operate or stop. 	
---------------------	----------------------------------------------------------------------------------------------------------------------------------------------------------------------------------------------------------	--

■ OPERATION PROCEDURE FOR OPERATION STATUS OF ALL UNITS (UP TO 16 UNITS CONNECTED)

Mode Monitoring	<ul style="list-style-type: none"> ■ : Run □ : Stop or not Connected ◻ (Blinking): Alarm <p>(The [ALARM] lamp on the lower right of the display section lights simultaneously).</p>	
------------------------	----------------------------------------------------------------------------------------------------------------------------------------------------------------------------------------------------------------------	--

■ OPERATION PROCEDURE FOR OPERATION STATUS OF ALL UNITS (17 OR MORE UNITS CONNECTED)

OPERATION STATUS OF GROUP (Mode Monitoring)	<ul style="list-style-type: none"> ■ : One or more air conditioners in the group are operated □ : All units in the group are stopped or not connected ◻ (Blinking): One or more air conditioners in the group are faulty. <p>(The [ALARM] lamp on the lower right of the display section lights simultaneously).</p>	<p>1 2 3 4 5...</p> <p>This indicates when a fault exist in the group 3.</p>
OPERATION STATUS IN GROUP (Mode Monitoring)	<p>Press the unit selection switch [UNIT] to set the unit number and press the [INDVL MNTR] switch. The display disappears and "UNIT 03" will change to "03". The air conditioner operation status in the group which is specified by the unit number is monitored.</p> <ul style="list-style-type: none"> ■ : Run □ : Stop or not Connected ◻ (Blinking): Alarm <p>(The [ALARM] lamp on the lower right of the display section lights simultaneously).</p>	<p>1 2 3 4 5...</p> <p>This indicates when a fault exist in the group 3.</p>

5. FIELD WORK INSTRUCTION

5.1. BURNT-OUT COMPRESSOR DUE TO INSUFFICIENT REFRIGERANT CHARGE

■ Question and Answer for Field Work

Example 1: Burnt-out Compressor due to Insufficient Refrigerant Charge	
Phenomenon	After commissioning, alarm code "08" sometimes occurred and compressors were burnt out after 2 month operation.
Cause	Refrigerant piping work was performed during summer season. Additional refrigerant was not sufficiently charged from the discharge side. This insufficient refrigerant charge resulted in discharge gas overheating and oil deterioration finally due to separated operation despite "08" alarm.
Countermeasure	1. The compressor was replaced with a new one. 2. Correct refrigerant amount was charged according to refrigerant piping length and connected indoor units.
Remarks	Additional Refrigerant Charging: Open the liquid stop valve slightly when the additional refrigerant is charged from the check joint of the liquid stop valve (discharge side) during the cooling operation. If the liquid valve is fully open, it is difficult to charge the additional refrigerant. Do not charge refrigerant from the gas stop valve.

5.2. INSUFFICIENT COOLING PERFORMANCE WHEN A LONG PIPING IS APPLIED

■ Question and Answer for Field Work

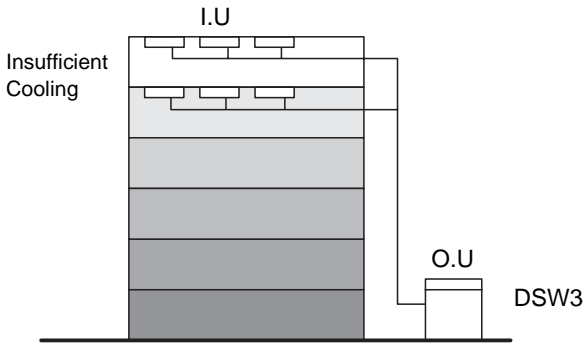
Example 2: insufficient Cooling Performance When a Long Piping is Applied	
Phenomenon	Sufficient Cooling was not available for an Indoor Unit which located at the farthest position.
Cause	In the case that an Outdoor Unit is Located 20 meters lower than Indoor Units, resetting of the dip switch, DSW3 is required. However, no setting was performed. Therefore, the largest discharge pressure was not increased, resulting in insufficient cooling performance for the Indoor. 
Countermeasure	Setting for DSW3 was Changed
Remarks	Pay a special attention to the liquid pipe size if the lift between the Indoor Units and Outdoor Units is higher than 20 meters. For details, see the "Piping Work in TC"

5.3. ABNORMALLY HIGH OPERATING SOUND (IN-THE-CEILING TYPE INDOOR UNIT)

■ Question and Answer for Field Work

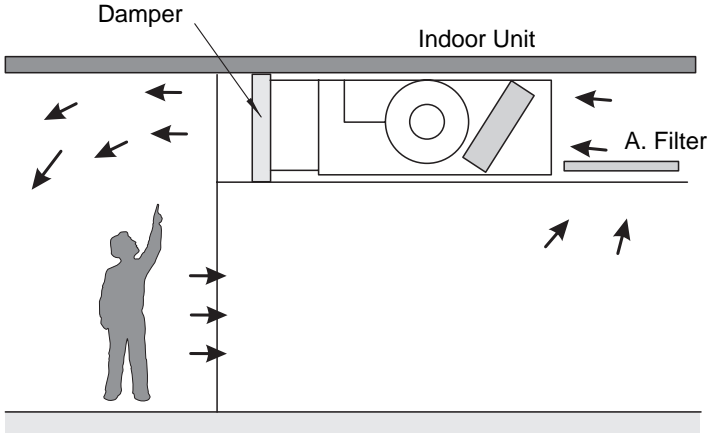
Example 3: Abnormally High Operating Sound (In-the-Ceiling Type Indoor Unit)	
Phenomenon	Operating sound during "Hi" speed was abnormally high.
Cause	<p>The indoor units was installed without ducts. Due to almost no external static pressure, abnormally big air volume was supplied, resulting in higher air speed through the heat exchanger.</p> 
Countermeasure	In order to reduce air flow, a plate as a damper at the discharge side was added.
Remarks	Please note that running current is increased when no external pressure is given to the indoor unit, resulting in overheating.

5.4. ALARM CODE "31"

■ Question and Answer for Field Work

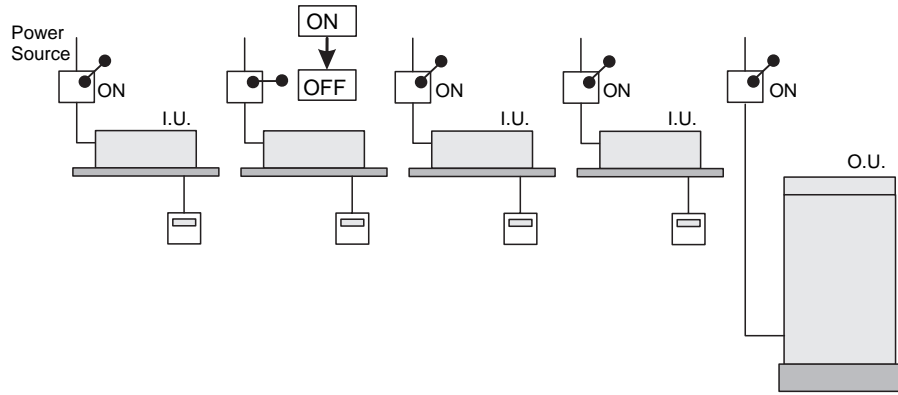
Example 4: Alarm Code "31"	
Phenomenon	Alarm code "31" sometimes occurred and the system was stopped.
Cause	<p>Combination of the indoor and outdoor unit was as follows.</p>  <p>This system was used in a tenant building. One of tenant's customers cut out the power switch for the indoor unit while other indoor units are running, resulting in different total indoor unit capacity setting in the same refrigerant cycle.</p>
Countermeasure	All the main power switches for the indoor units were always ON.

5.5. NOT COOLING WELL DUE TO INSUFFICIENT INSTALLATION SPACE FOR OUTDOOR UNIT

■ Question and Answer for Field Work

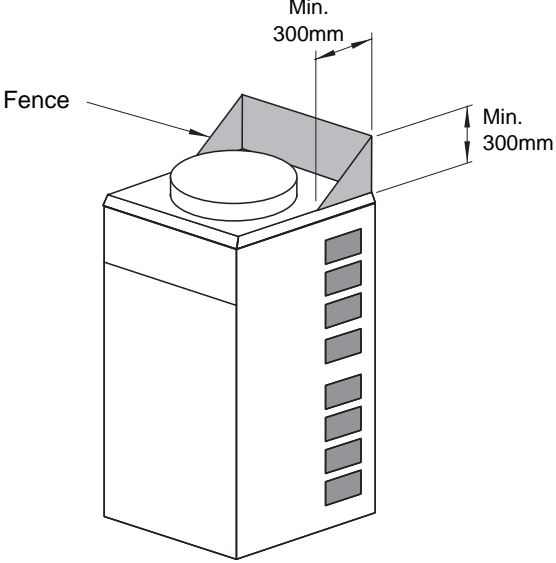
Example 5: Not Cooling Well due to Insufficient Installation Space for Outdoor Unit	
Phenomenon	Cooling operation was well performed through the intermediate season. However, the cooling operation was not well available when the outdoor temperature was higher than 35 °C.
Cause	<p>As the outdoor units were installed without a sufficient installation space, the hot discharge air from other outdoor units was circulated. In this case, though the outdoor temperature was 35 °C, the actual suction air temperature was nearly 50 °C and Protection System from Excessively High Suction Pressure was activated, the frequency of the compressor was decreased and the cooling capacity was also decreased accordingly. As the outdoor units in-line were installed back to back with a distance of 600mm between each outdoor unit's back, the hot discharged air from other outdoor units was circulated.</p>  <p>The diagram shows a 3D perspective view of an outdoor unit. On top of the unit is a circular fan. On the right side of the unit, there is a vertical stack of five rectangular vents. A fence is mounted on the back of the unit, extending over the fan and the vents. The fence is shown as a rectangular structure with a height of at least 300mm and a width of at least 300mm. The unit is shown in a perspective view, with the front and right sides visible.</p>
Countermeasure	To protect the unit from a short circuit, fences were mounted at the discharge air side as shown below.

5.6. SELECT GUIDE OF DRAIN PIPE FOR INDOOR UNIT

■ Selecting Method of Drain Pipe Diameter

1. Calculation of Drain Flow Volume

Calculate from that the drain flow volume is approximately 3 (l/hr) per 1HP of the indoor unit nominal capacity.

For Example:

Common drain pipe for four 2HP indoor units and four 2.5HP indoor units.	
Total Horse Power of Indoor Unit	$4 \times 2\text{HP} + 4 \times 2.5\text{HP} = 18\text{HP}$
Total Drain Flow Volume	$18\text{HP} \times 3 (\text{l/hr} \times \text{HP}) = 54 (\text{l/hr})$

2. Select Drain Pipe from Table A and B

Horizontal Common Pipe with Slope 1/50	VP30 for above Example
Horizontal Common Pipe with Slope 1/100	VP30 for above Example
Vertical Common Pipe	VP30 for above Example

Table A. Permissible Drain Flow Volume of Horizontal Vinyl Pipe

JIS Symbol	Inner Diameter (mm)	Permissible Flow Volume (l/hr)	
		Slope=1/50	Slope=1/100
VP20	20	39	27
VP25	25	70	50
VP30	31	125	88
VP40	40	247	175
VP50	51	472	334

NOTE

VP20 and VP25: Not Applicable to Common Pipe
VP30, 40 and 50: Applicable to Common Pipe

Table B. Permissible Drain Flow Volume of Vertical Vinyl Pipe

JIS Symbol	Inner Diameter (mm)	Permissible Flow Volume (l/hr)
VP20	20	220
VP25	25	410
VP30	31	730
VP40	40	1400
VP50	51	2760
VP65	67	5710
VP75	77	8280

NOTE

VP20, 25 and 30: Not Applicable to Common Pipe
VP40, 50, 65 and 75: Applicable to Common Pipe

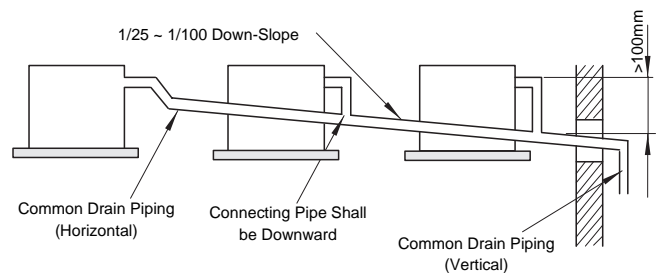

5.7. CAUTION ON REFRIGERANT LEAKAGE

■ Maximum Permissible Concentration of H(C)FC Gas

The refrigerant R407C (or R22), charged in the SET-FREE FSG system, is an incombustible and non-toxic gas. However, if leakage occurs and gas fills a room, it may cause suffocation.

The maximum permissible concentration of H(C)FC gas, R407C in air is 0.3 kg/m³ according to the refrigeration and air conditioning facility standard (KHK S 0010) by the KHK (High Pressure Gas Protection Association) Japan. Therefore, some effective measure must be taken to lower the R407C concentration in air below 0.3 kg/m³, in case of leakage.

■ Calculation of Refrigerant Concentration

- Calculate the total quantity of refrigerant R (kg) charged in the system connecting all the indoor units of rooms to be air-conditioned.
- Calculate the room Volume V (m³) of each room.
- Calculate the refrigerant concentration C (kg/m³) of the room according to the following equation:

R	R: Total Quantity of Charged Refrigerant (kg)
— = C	V: Room Volume (m ³)
V	C: Refrigerant Concentration (≤ 0.3 kg/m ³)

The facility shall be arranged as follows referring to the KHK standards, so that the refrigerant concentration will be below 0.3 kg/m³.

- Provide a shutterless opening which will allow fresh air to circulate into the room.
- Provide a doorless opening of 0.15% or more size to the floor area.
- Provide a Ventilator, Linked with a gas leak detector, of 0.4 m³/min or more ventilating capacity per Japanese Refrigeration Ton (=compressor displacement m³/h/8.5(R22) or 9.8(R407)) of the air conditioning system utilizing refrigerant R-22.

RAS-5FSG	2.15 ton
RAS-8FSG	3.74 ton
RAS-10FSG	4.01 ton
RAS-16FSG	5.78 ton
RAS-20FSG	7.36 ton

RAS-5FS3	2.48 ton
RAS-8FS3	4.31 ton
RAS-10FS3	4.63 ton
RAS-16FS3	6.66 ton
RAS-20FS3	8.49 ton

- Pay a special attention to the place, such as a basement, etc., where refrigerant can stay, since refrigerant is heavier than air.

■ Countermeasure for Refrigerant Leakage According to KHK Standard

Example:

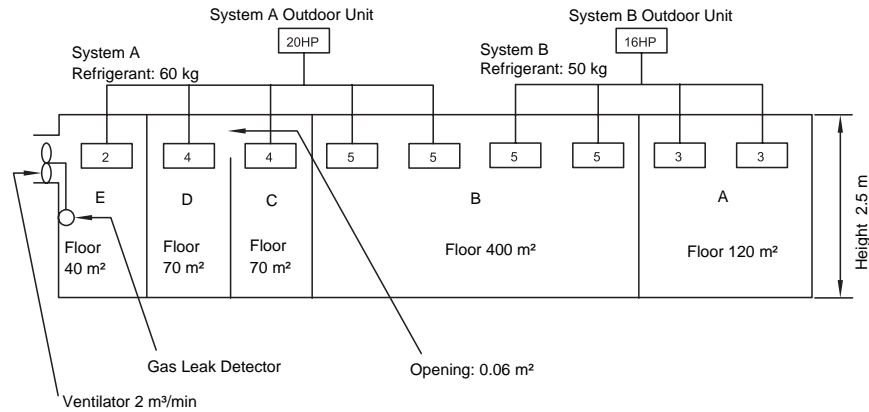

Room	R (kg)	V (m³)	C (kg/m³)	Countermeasure	Example:
A	50	300	0.17	-	British Standard BS4434 1989 R22 Commercial Office Building Class D Occupancy $MR = C \times V$ MR: Maximum Charge or Leakage of Refrigerant (kg) C: Maximum Allowable Concentration = 0.17 (kg/m³) V: Volume of Space (m³)
B	110	1000	0.11	-	
C	60	175	0.34	0.06 m² Opening	
D	60	175	0.34	0.06 m² Opening	
C+D	60	350	0.171	-	
E	60	100	0.6	2 m³/min Ventilator Linked with Gas Leak Detector	

5.8. MAINTENANCE WORK

■ For Indoor Unit and Outdoor Unit

- Fan and Fan Motor
 - Lubrication: All fan motors are pre-lubricated and sealed at the factory. Therefore, no lubricating maintenance is required.
 - Sound and Vibration: Inspect for abnormal sound and vibration
 - Rotation: Inspect for clockwise rotation and rotating speed.
 - Insulation: Inspect for electrical insulation resistance.
- Heat Exchanger
 - Clog: Inspect and remove any accumulated dirt and dust from the heat exchanger at regular intervals. As for outdoor unit, other obstacles such as growing grass and pieces of paper, which might restrict air flow, should also be removed.
- Piping Connection
 - Leakage: Inspect for refrigerant leakage at piping connection.
- Cabinet
 - Stain and Lubrication: Inspect and remove any stain and lubrication.
 - Fixing Screw: Inspect and fix loosened or lost screws. Insulation: Inspect and repair peeled thermal insulation material on cabinet.
- Electrical Equipment
 - Activation: Inspect for abnormal activation of the magnetic contactor, auxiliary relay, PCB and etc.
 - Line Condition: Pay attention to working voltage, amperage and phase balance. Inspect for faulty contact caused by loosened terminal connections, oxidized contacts, foreign matter, and other items. Inspect for electrical insulation resistance.
- Control and Protective Devices
 - Setting: Do not readjust the setting in the field unless the setting is maintained at a point other than the point listed in "9.6. SAFETY AND CONTROL DEVICE SETTING" of "TC"

■ For Indoor Unit

- Air Filter
 - Cleaning: Inspect and remove any accumulated dirt and dust according to "18.2 Filter Cleaning" of "TC".
- Drain Pan, Drain - up Mechanism and Drain Pipe
 - Drain Line: Inspect and clean the condensate drain line at least twice a year.
 - Drain-up Mechanism: Inspect for activation of drain-up mechanism.
- Float Switch
 - Activation: Inspect for activation of float switch.

■ For Outdoor Unit

- Compressor
 - Sound and Vibration: Inspect for abnormal sound and vibration.
 - Activation: Inspect for that the voltage drop of power supply line is within 15% at start and within 2% during operation.
- Reverse Valve
 - Activation: Inspect for any abnormal activating sound.
- Strainer
 - Clog: Inspect for that no temperature difference between both ends.
- Earth Wire
 - Earth Line: Inspect for continuity to the earth.
- Oil Heater
 - Activation: The oil heater should be activated at least 12 hours before start-up, by switching ON the main power source.

5.9. SERVICE & MAINTENANCE RECORD

No.	Check Item	Action	Judgement	
1	Is service space sufficient?		Yes	No
2	Short circuit of Discharged Air?		Yes	No
3	Any Heat Influence		Yes	No
4	Is earth wire connected?		Yes	No
5	Refrigeration Piping		Good	Not Good
6	Fixing of Units		Good	Not Good
7	Any Damage on Outer or Internal Surface?		Yes	No
8	Checking of Scew and Bolts	Tighten if loosen	Tightened	Not Tightened
9	Tightening of Terminal Screws	Tighten all terminals screws by phillips driver	Tightened	Not Tightened
10	Are compressor terminals tightly fixed?	Push all terminals	Pushed	Not Pushed
11	Insulation Resistance	Measure Insulation resistance by Insulation resistance-meter. Comp. and Fan Motor: greater than 3MΩ Others: greater than 3MΩ	Good	Not Good
12	Does Drain Water smoothly flow?	Check for smooth flow by pouring water.	Good	Not Good
13	Check for Leakage at compressor.	Check for any Leakage	Good	Not Good
14	Check for Leakage at Outdoor heat exchanger	ditto	Good	Not Good
15	Check for Leakage at Indoor heat exchanger	ditto	Good	Not Good
16	Check for Leakage at 4-way valve	ditto	Good	Not Good
17	Check for Leakage at check valve	ditto	Good	Not Good
18	Check for Leakage at accumulator	ditto	Good	Not Good

No.	Check Item	Action	Judgement	
19	Check for Leakage at Strainer	ditto	Good	Not Good
20	Check for Leakage at electronic Ex. Valve	ditto	Good	Not Good
21	Check for Leakage at piping	ditto	Good	Not Good
22	Check for direction of fans	by Viewing or Air Flow Volume	Good	Not Good
23	Voltage among each Phase	Higher than 220V	Good	Not Good
24	Vibration and Sound	Check fan, compressor, piping, etc	Good	Not Good
25	Activation of each Operation Mode	Check Activation of Cool, Heat, Stop, and Temp. switches	Good	Not Good
26	High Pressure Cut-out Switch	Check actual activation value	Good	Not Good
27	Check activation of drain mechanism	Check it during cooling operation	Good	Not Good
28	Indoor Inlet Air Temp. DB/WB		(°C)DB	(°C)WB
29	Indoor Outlet Air Temp. DB/WB		(°C)DB	(°C)WB
30	Outdoor Inlet Air Temp. DB/WB		(°C)DB	(°C)WB
31	Outdoor Outlet Air Temp. DB/WB		(°C)DB	(°C)WB
32	High Pressure Switch		kg/cm ² G	
33	Low Pressure Switch		kg/cm ² G	
34	Operating Voltage		V	
35	Operating Current		A	
36	Instruction for cleaning of Air Filter to client		Done	Not Yet
37	Instruction for cleaning of Method to client		Done	Not Yet
38	Instruction for Operation to client		Done	Not Yet

5.10. SERVICE & MAINTENANCE RECORD BY 7-SEGMENT DISPLAY

■ Data Sheet for Checking by 7-Segment Display

Outdoor Unit Model (Serial No.)	RAS-	(Serial No.)	RAS-	(Serial No.)	RAS-	(Serial No.)	RAS-	(Serial No.)	RAS-	(Serial No.)																			
1. Operation Mode																													
2. Test Run Start Time																													
3. Data Collect Start Time																													
4. Read Out Data from 7-segment																													
Protection Control Code																													
Outdoor Microcomputer Output	SC	52C ₁	52C ₂	52C ₃	52C ₄	AC Chopper	52C ₁	52C ₂	52C ₃	52C ₄	AC Chopper	52C ₁	52C ₂	52C ₃	52C ₄	AC Chopper	52C ₁	52C ₂	52C ₃	52C ₄	AC Chopper	52C ₁	52C ₂	52C ₃	52C ₄	AC Chopper			
		FAN ₂	RS	20A	21 ₁	21 ₂	OH	FAN ₂	RS	20A	21 ₁	21 ₂	OH	FAN ₂	RS	20A	21 ₁	21 ₂	OH	FAN ₂	RS	20A	21 ₁	21 ₂	OH	FAN ₂	RS	20A	21 ₁
Indoor Total Operating Capacity	oP																												
Inverter Frequency	H1																												
Compressor Running Quantity	CC																												
Outdoor Fan Step	Fo																												
Outdoor Unit Expansion Valve Opening	oE1																												
	oE2																												
	oEb																												
Discharge Pressure	Pd																												
Suction Pressure	Ps																												
Discharge Gas Temperature	Td1																												
	Td2																												
	Td3																												
	Td4																												
Heat exchanger Liquid Pipe Temperature	TE1																												
	TE2																												
Outdoor Temperature	To																												
Compressor Running Current	A1																												
	A2																												
	A3																												
	A4																												
Indoor Unit (Unit No.)																													
Expansion Valve Opening	iE																												
Heat Exchanger Liquid Temp.	TL																												
Heat Exchanger Gas Temp.	TG																												
Intake air Temp.	Ti																												
Outlet Air Temp.	To																												
Capacity (×1/8HP)	CA																												
Indoor unit Soppage Cause Code	d1																												
Restricted Control for Prevention of Compression Ratio Decrease	c11																												
Restricted Control for Prevention of High Pressure Increase	c13																												
Restricted Control for Prevention of Discharge Gas Temp. Increase	c15																												
Restricted Control for Prevention of TdSH	c16																												
Restricted Control for Prevention of Overcurrent	c17																												
Accumulated operation Time of Comp.1	UJ1																												
Accumulated operation Time of Comp.2	UJ2																												
Accumulated operation Time of Comp.3	UJ3																												
Accumulated operation Time of Comp.4	UJ4																												
Outdoor Alarm Code	AC																												
Inverter Stoppage Cause Code	iTC																												
Total Indoor Unit Capacity (×1/8HP)	CP																												
Total Indoor Unit Quantity	AA																												
Refrigerant System Address	GA																												

R.C.Sw: Remote Control Switch, O.U.: Outdoor Unit, I.U.: Indoor Unit

52C1: CMC1, 52C2: CMC2, 52C3: CMC3, 52C4: CMC4

FAN2: Constant Speed Fan (16, 20HP Only), RS: Relay for Starting

20A: Solenoid Valve (SVA), 211: Four Way Valve (RVR1), 212: Four Way Valve (RVR2), OH: Oil Heater

*: Multiply 1/8 by the code on the 7-segment.

5.11. SERVICE & MAINTENANCE RECORD BY REMOTE CONTROL SWITCH

■ Data Sheet for Checking by Remote Control Switch

Time	:	:	:	:	:	:	:	:
I.U. Model								
I.U. Serial No.								
I.U. No./Alarm Code								
	Check Mode 1	Check Mode 2	1 - 2	1 - 2	1 - 2	1 - 2	1-2	1-2
B Temp. Indication								
Set Temp.	b1	--						
Inlet air Temp.	b2	91						
Discharge Air Temp.	b3	92						
Liquid Pipe Temp.	b4	93						
Remote Thermistor temp.	b5	--						
Outdoor Air Temp.	b6	94						
Gas Pipe Temp.	b7	95						
Evaporating Temp. at Heating	b8	96						
Control Information	b9	97						
Control Top Temp.	bA	98						
C Micro Computer state Indication								
I.U. Micro-Computer	C1	--						
O.U. Micro-Computer	C2	--						
D Stopping Cause								
Stopping Cause state Indication	d1	--						
E Alarm Occurrence								
Times of Abnormality	E1	--						
Times of Power Failure	E2	--						
Times of Abnormal Transmitting	E3	--						
Times of Inverter Tripping	E4	--						
F Automatic louver State								
Louver Sensor State	F1	--						
H Pressure, Frequency State indication								
Discharge Pressure	H1	99						
Suction Pressure	H2	9A						
Control Information	H3	9b						
Operating Frequency	H4	9C						
J I.U. Capacity Indication								
I.U. Capacity (x1/8HP)	J1	--						
O.U. Code	J2	--						
Refrigerant Cycle Number	J3	--						
Refrigerant Cycle Number	J4	--						
L Opening of Ex. Valve								
I.U. Ex. Valve	L1	9d						
O.U. Ex. Valve 1	L2	9E						
O.U. Ex. Valve 2	L3	--						
O.U. Ex. Valve B	L4	--						
P Running Current Indication (Reference)								
Comp. Current	P1	9F						

Client:

Installation Date:

System No:

Date Checked:

Checked by:

Result

HITACHI

SMGB0001- 06/01 - Printed in Spain